

REP.	REFERENCE	PDS	NB	MZ
1	895.7001	3,0	1	260
2	895.7002	3,0	1	260
3	895.7003	3,4	1	601
4	895.7004	3,4	1	602
5	895.7005	2,1	2	
6	895.7006	2,6	1	080
7	895.7007	2,6	1	080
8	895.7008	3,2	1	080/140
9	895.7009	3,2	1	080/140
10	895.7010	1,0	1	
11	895.7011	1,0	1	
12	895.7012	0,9	1	
13	895.7013	0,9	1	
14	895.7014	1,8	1	
15	895.7015	1,7	1	200
16	895.7016	2,9	1	200
17	895.7017	2,9	1	200
18	895.7018	1,0	1	
36	696.736	3,0	1	260
37	696.737	3,0	1	260
38	696.738	2,1	1	141
39	696.739	2,1	1	142
40	696.740	2,8	1	080/140
41	696.741	2,8	1	080/140
42	696.742	0,1	2	
43	696.743	2,3	1	140
44	696.744	2,3	1	140
45	696.745	2,8	1	200
46	696.746	2,8	1	200
47	696.747	2,4	1	
48	696.748	2,4	1	
49	696.749	2,9	1	
50	696.750	2,9	1	
	V11	0,1	2	
	V32	0,1	2	
	E12	0,1	2	

M 8-30	4
M 10-25	4
M 12-25	2
M 12-30	8
M 12-40	2
M 12-55	6
M 12-90	2
M 12-110	4
M 12-130	2

M 8	10
M 12	4

MU 12	2
-------	---

○ Avec ou sans mécanique
With or without mechanical elements
Con o senza parti meccaniche
Mit oder ohne Aggregate
Con ó sin mecanica desmontada

PEUGEOT / CITROEN / FIAT / LANCIA

895.300

82 Kg 03.04.2002 423-D-21A

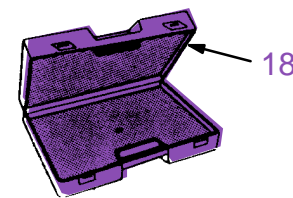
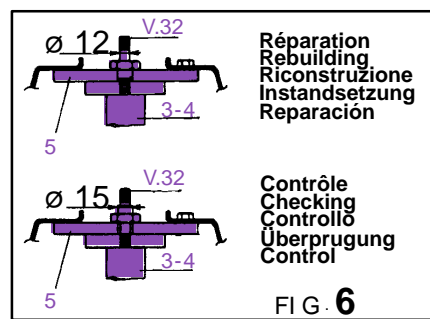
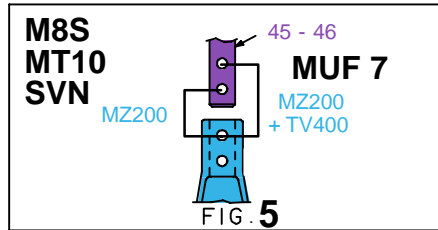
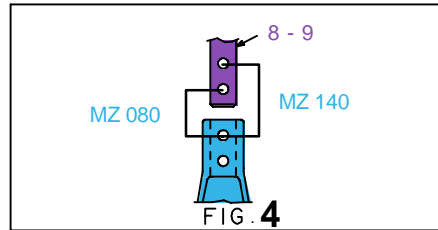
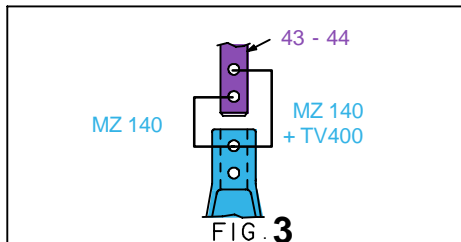
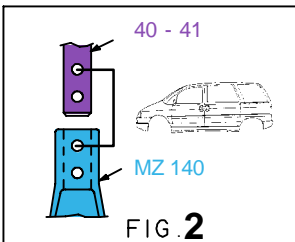
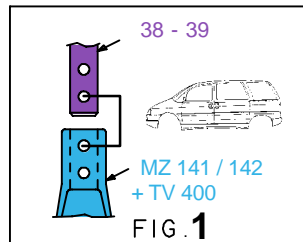
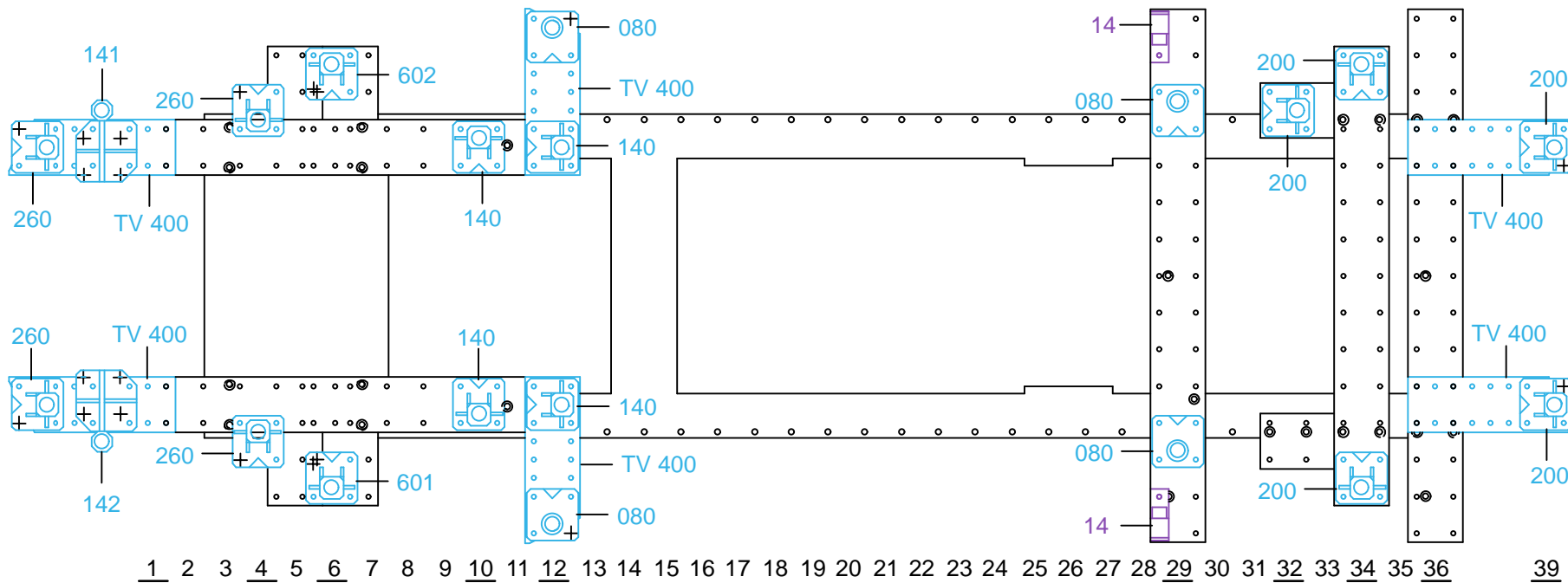

895.300-RVA3-1 00

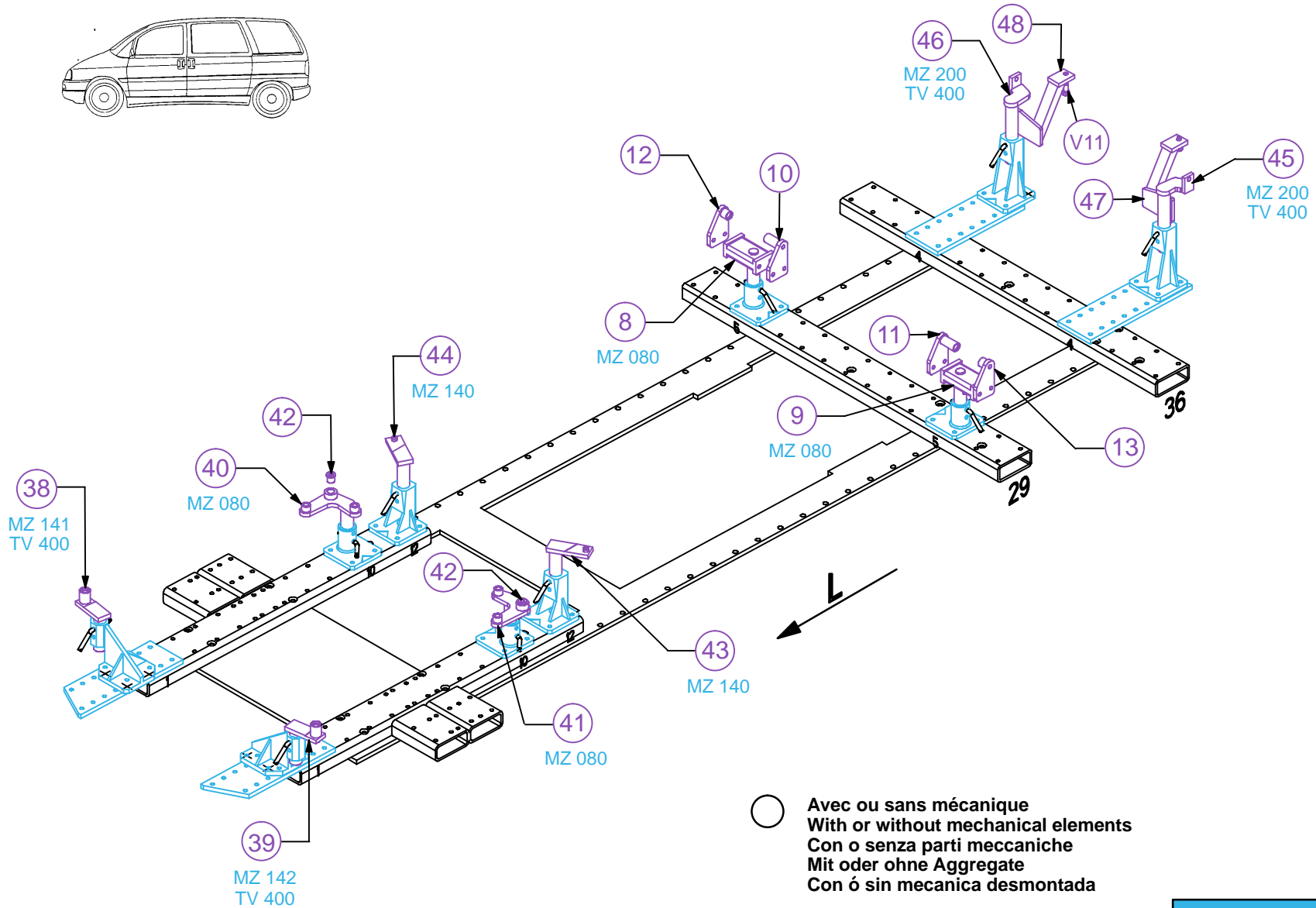
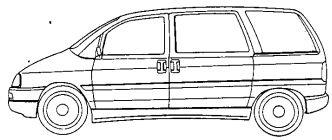

PEUGEOT / CITROEN / FIAT / LANCIA

895.300

82 Kg 03.04.2002 423-D-21B

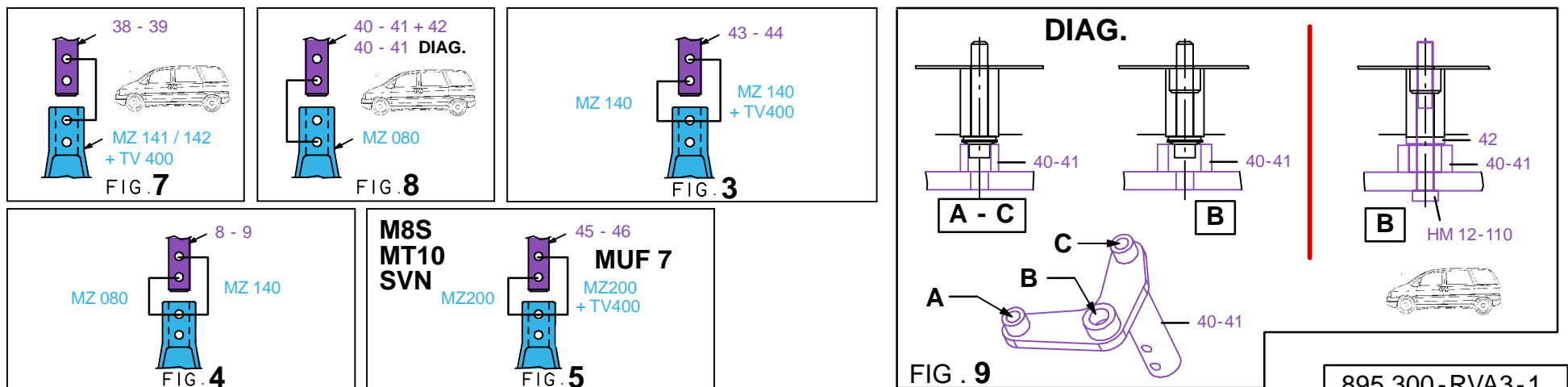
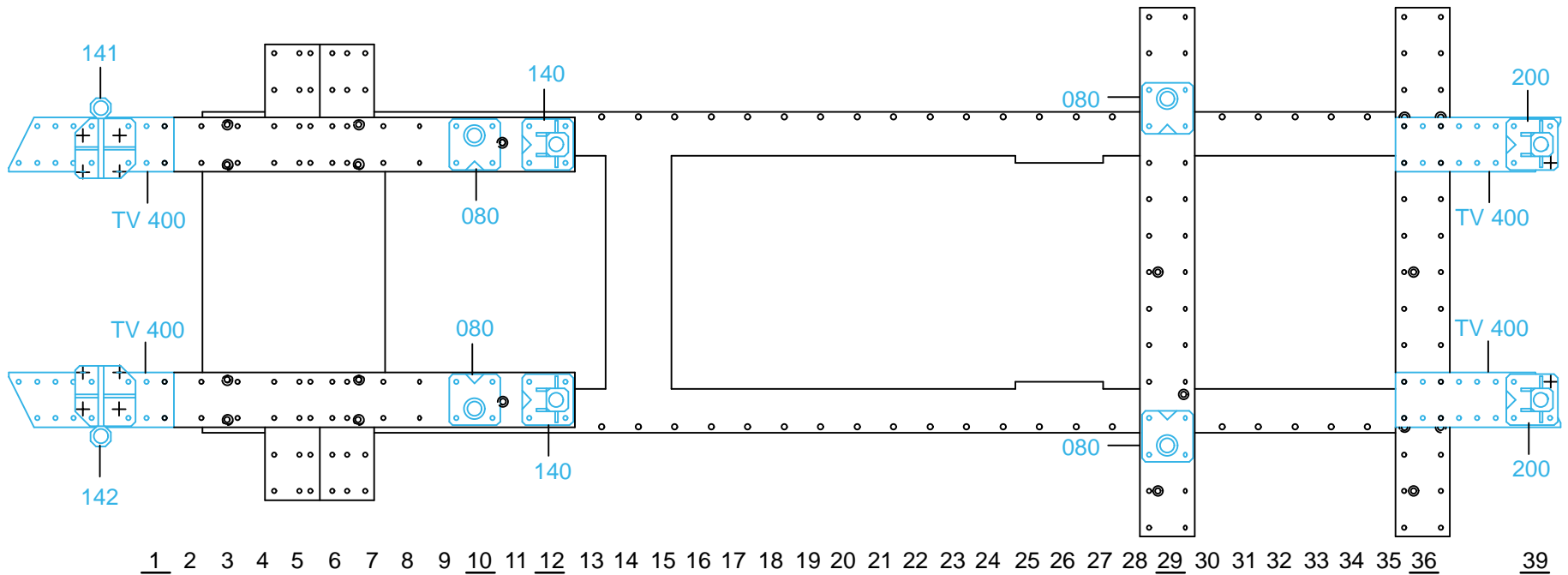

895.300-RVA3-1 00

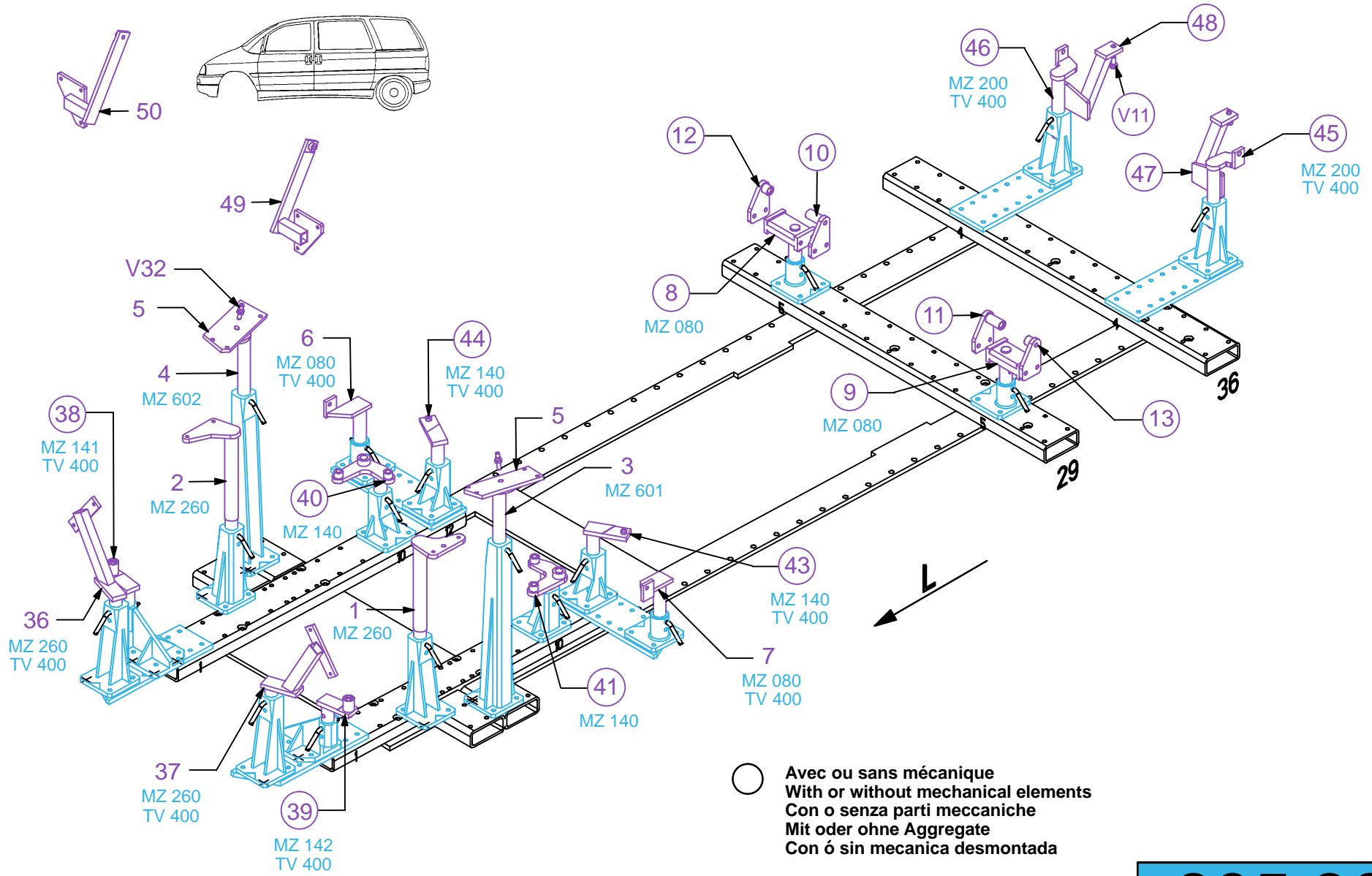

PEUGEOT / CITROEN / FIAT / LANCIA

895.300

82 Kg 03.04.2002 423-D-21C

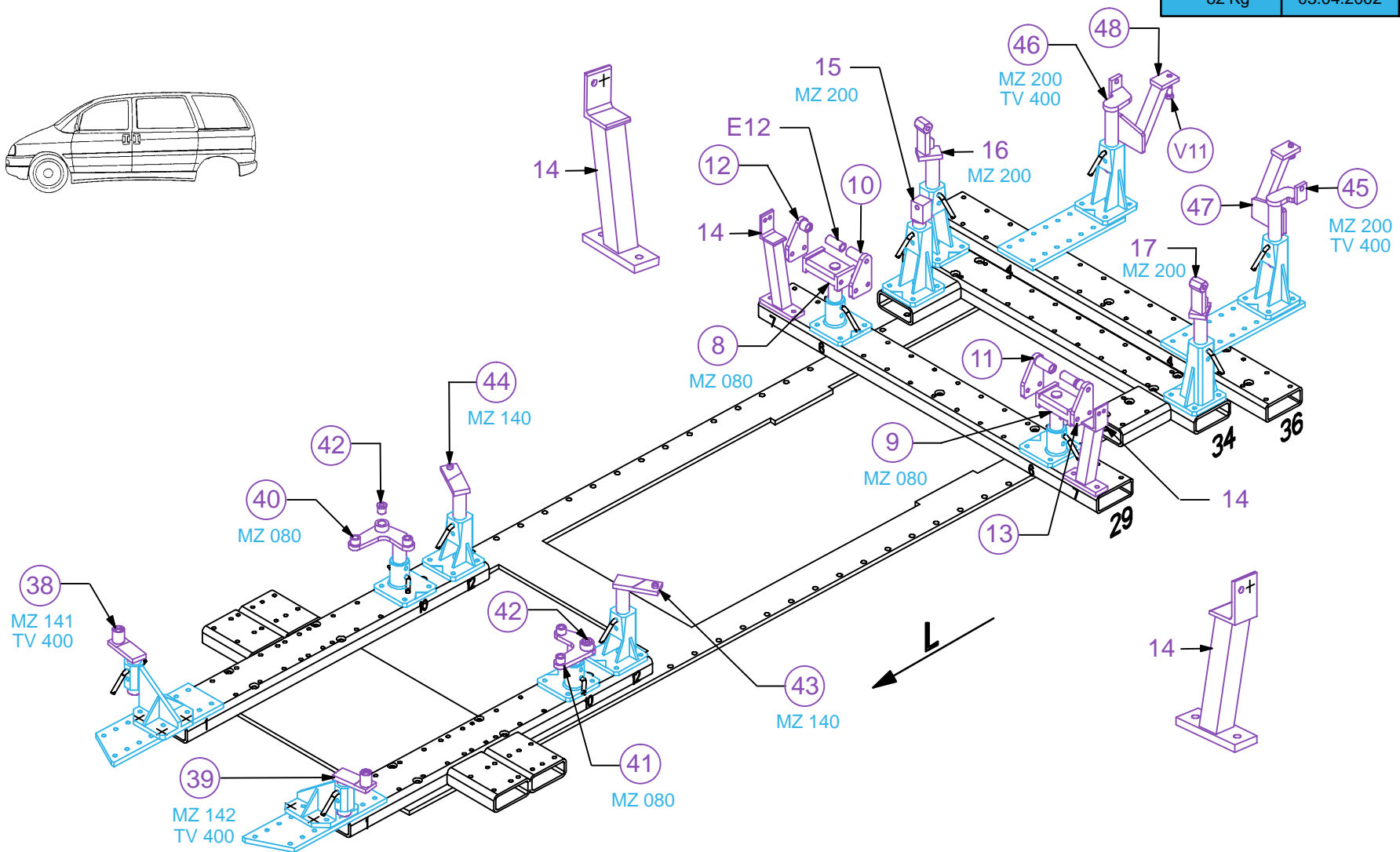

895.300-RA3-2 00