

REP.	REFERENCE	PDS	NB	MZ
1	866.7001	1,7	1	140
2	866.7002	1,7	1	140
3	866.7003	3,1	1	141
4	866.7004	3,1	1	142
5	866.7005	2,4	1	601
6	866.7006	2,4	1	602
7	866.7007	1,9	1	200
8	866.7008	1,9	1	200
9	866.7009	1,6	1	080
10	866.7010	1,6	1	080
11	866.7011	2,0	1	080
12	866.7012	2,0	1	080
13	866.7013	2,4	1	140
14	866.7014	2,4	1	140
15	866.7015	2,4	1	140
16	866.7016	1,5	1	
17	866.7017	1,5	1	
18	866.7018	2,5	1	260
19	866.7019	2,5	1	260
20	866.7020	2,6	1	260
21	866.7021	2,6	1	260
22	866.7022	2,4	1	200
23	866.7023	2,4	1	200
24	866.7024	0,3	2	
	D.090	0,6	2	
	B79	0,2	2	
	B39	0,1	2	
	CD.08	2,4	6	

	M 12-25	12
	M 12-30	6
	M 14-20	2
	M 10x1,25-30	2
	M 14x1,50-40	2
	M 14x1,50-60	2
	M 14x1,50-70	2
CHc 12-25 TB	12	
	M 12	2
	MU 14	2

○ Avec ou sans mécanique  
With or without mechanical elements  
Con o senza parti meccaniche  
Mit oder ohne Aggregate  
Con ó sin mecanica desmontada

**TOYOTA**

**866.300**

69 Kg 07.03.2001 434-D-75A

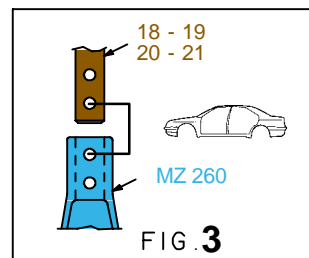
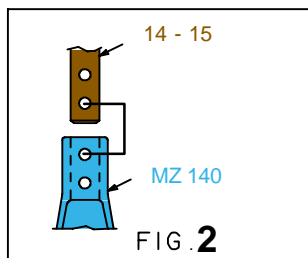
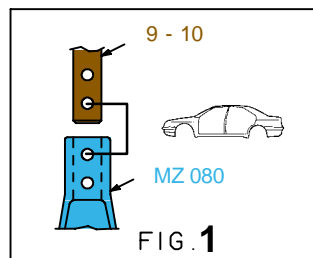
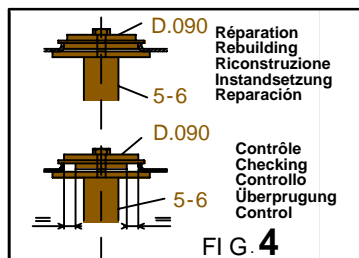
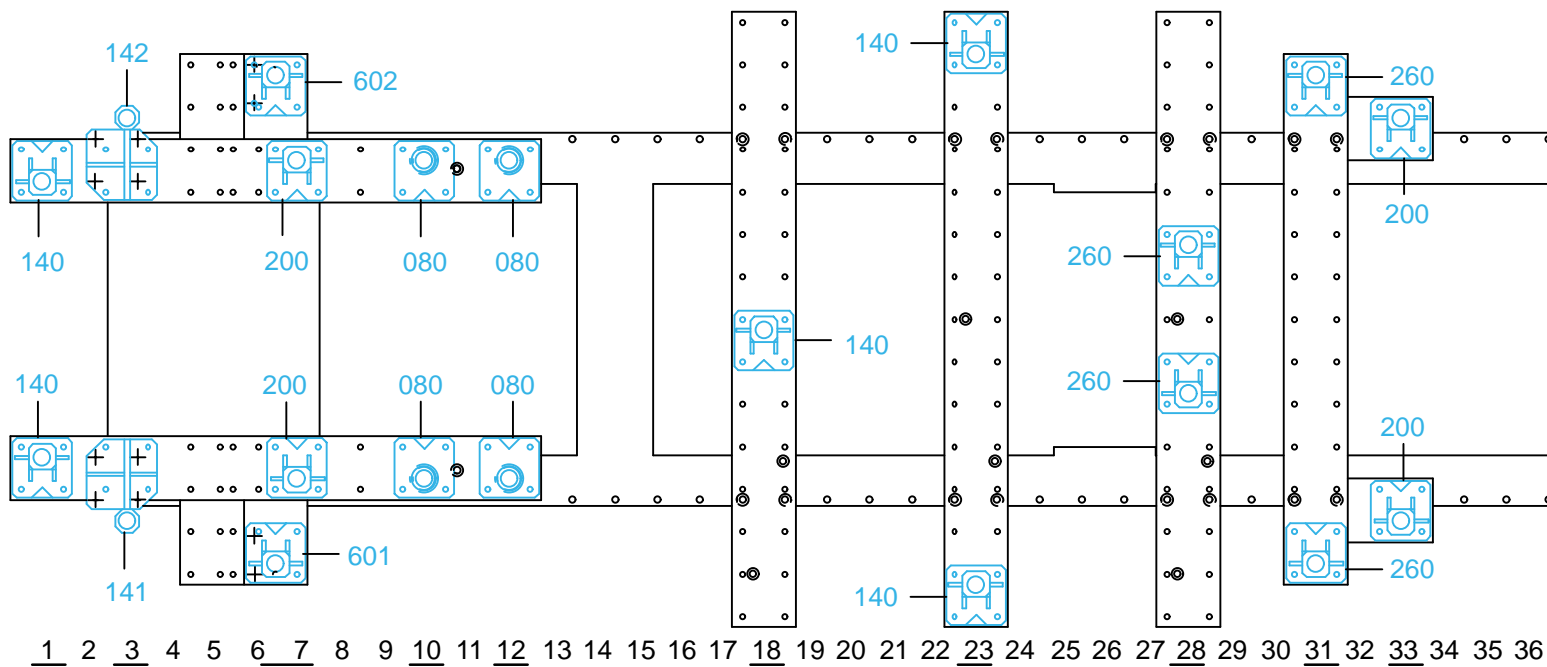

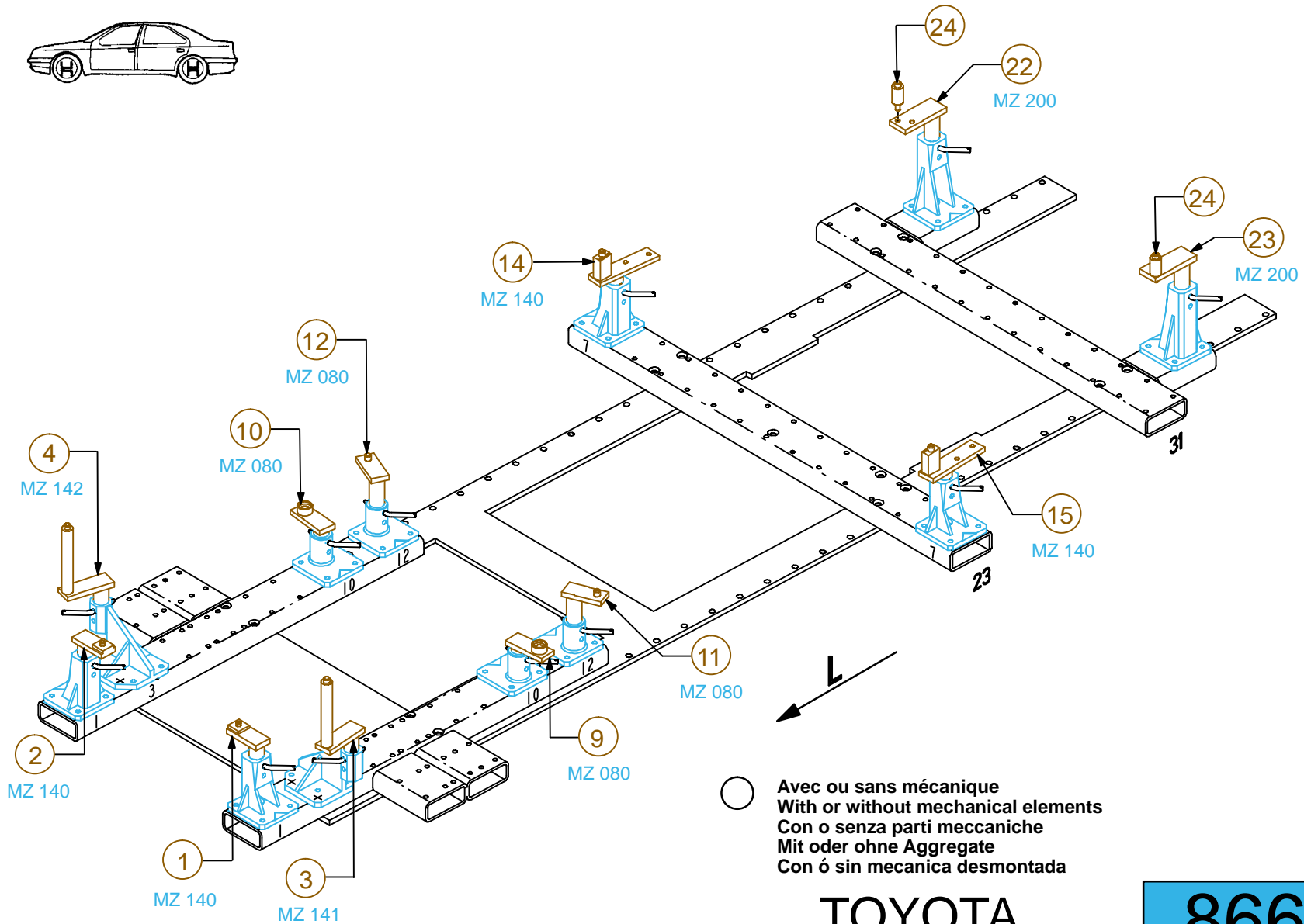
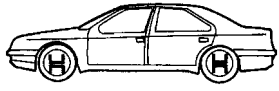

○ Avec ou sans mécanique  
With or without mechanical elements  
Con o senza parti meccaniche  
Mit oder ohne Aggregate  
Con ó sin mecánica desmontada

**TOYOTA**

**866.300**

69 Kg

07.03.2001

434-D-75B

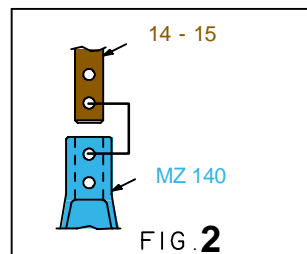
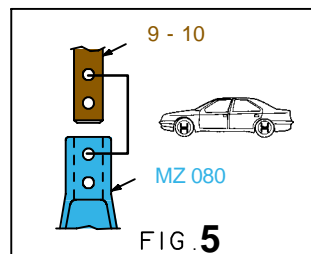
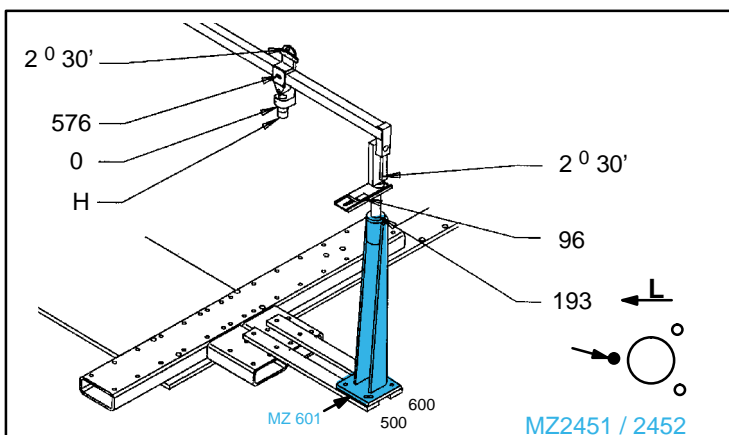
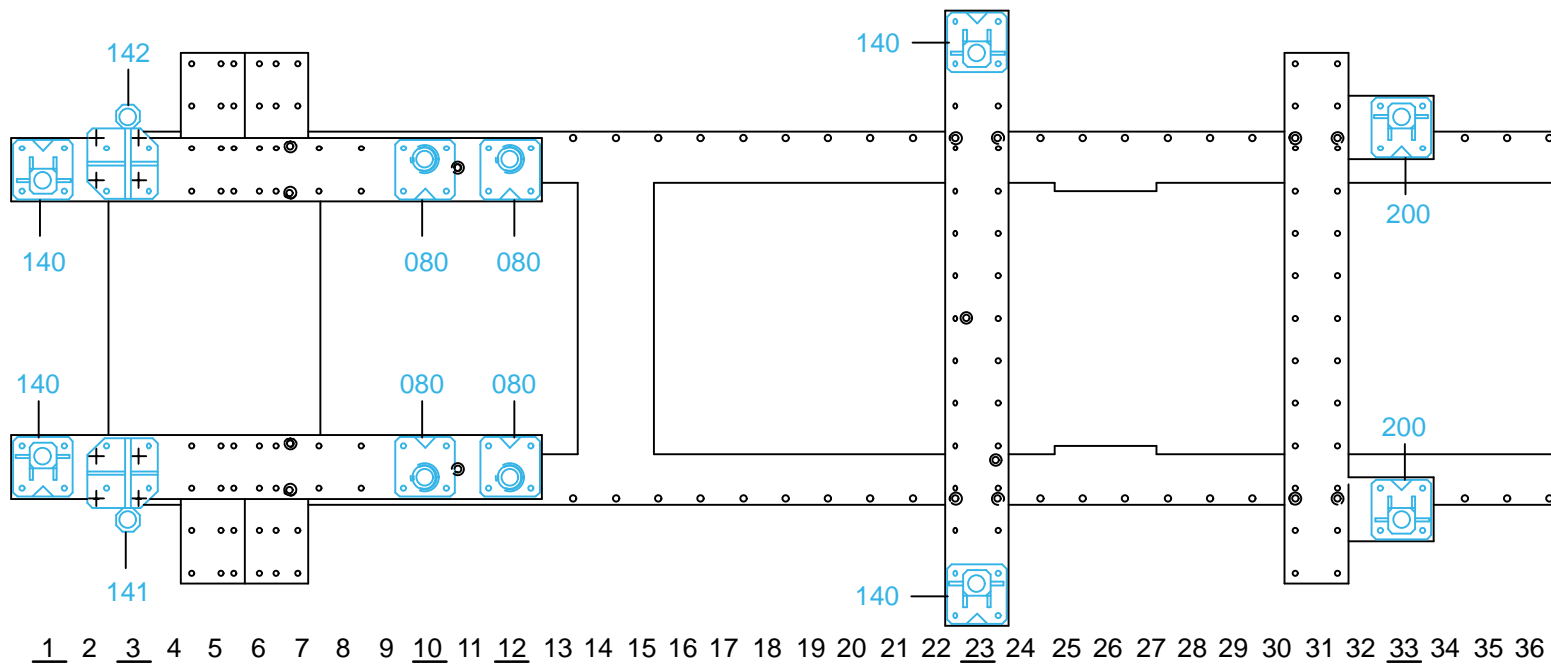



5 Portes  
5 -Türig  
5 Door  
5 Porte  
5 Puertas

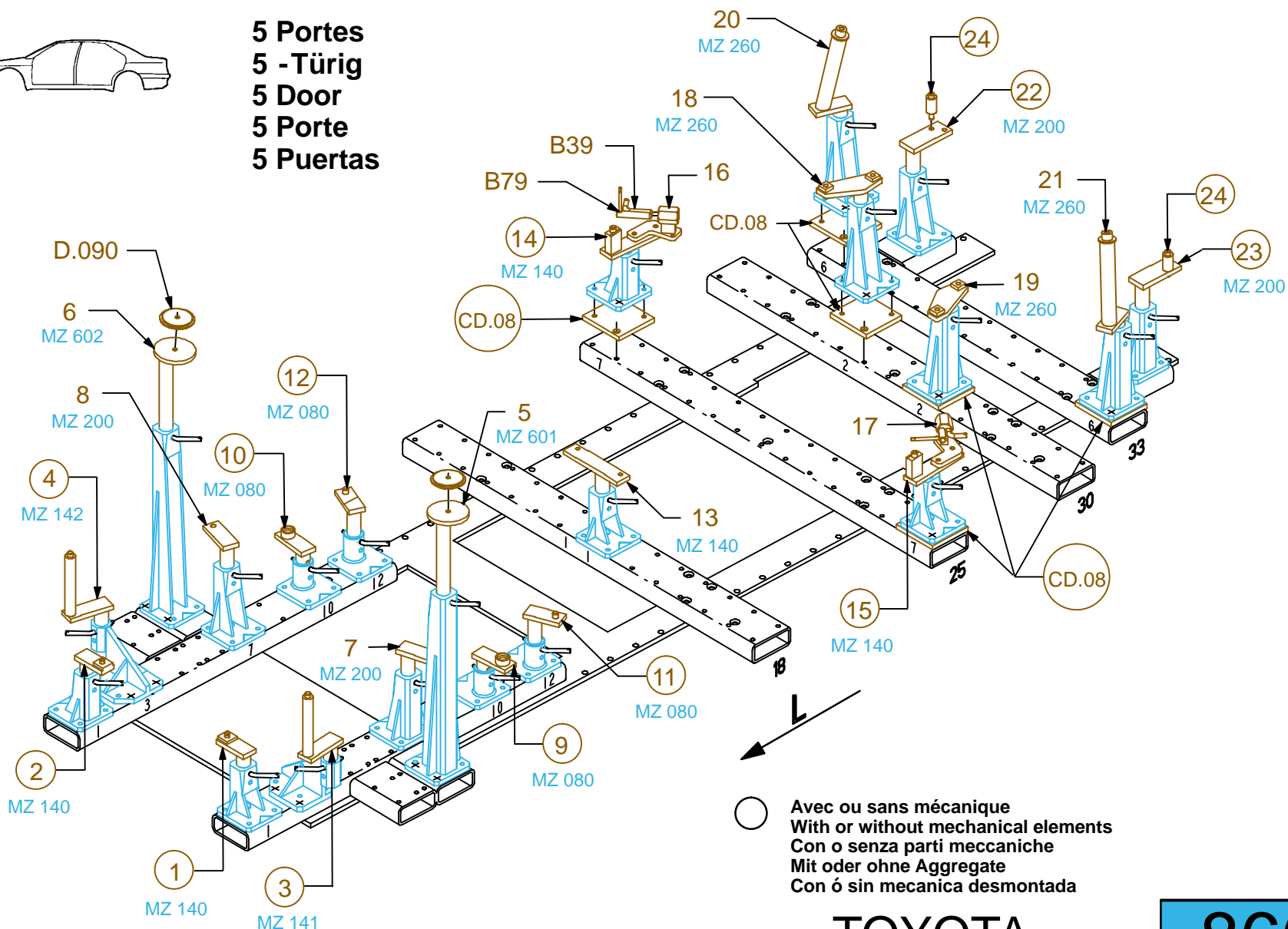

**TOYOTA**

**866.300**

69 Kg    07.03.2001    434-D-75C

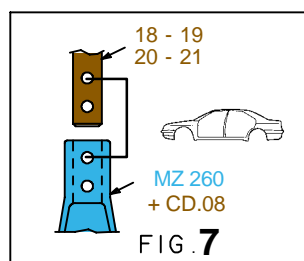
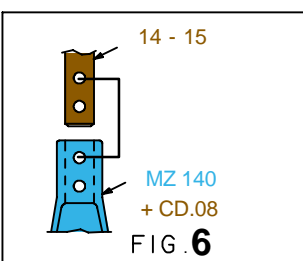
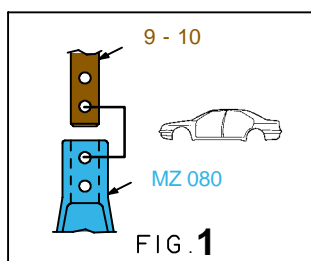
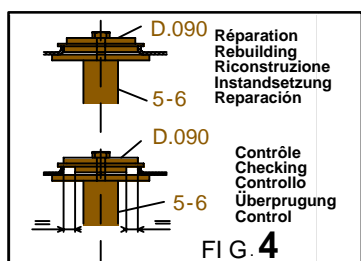
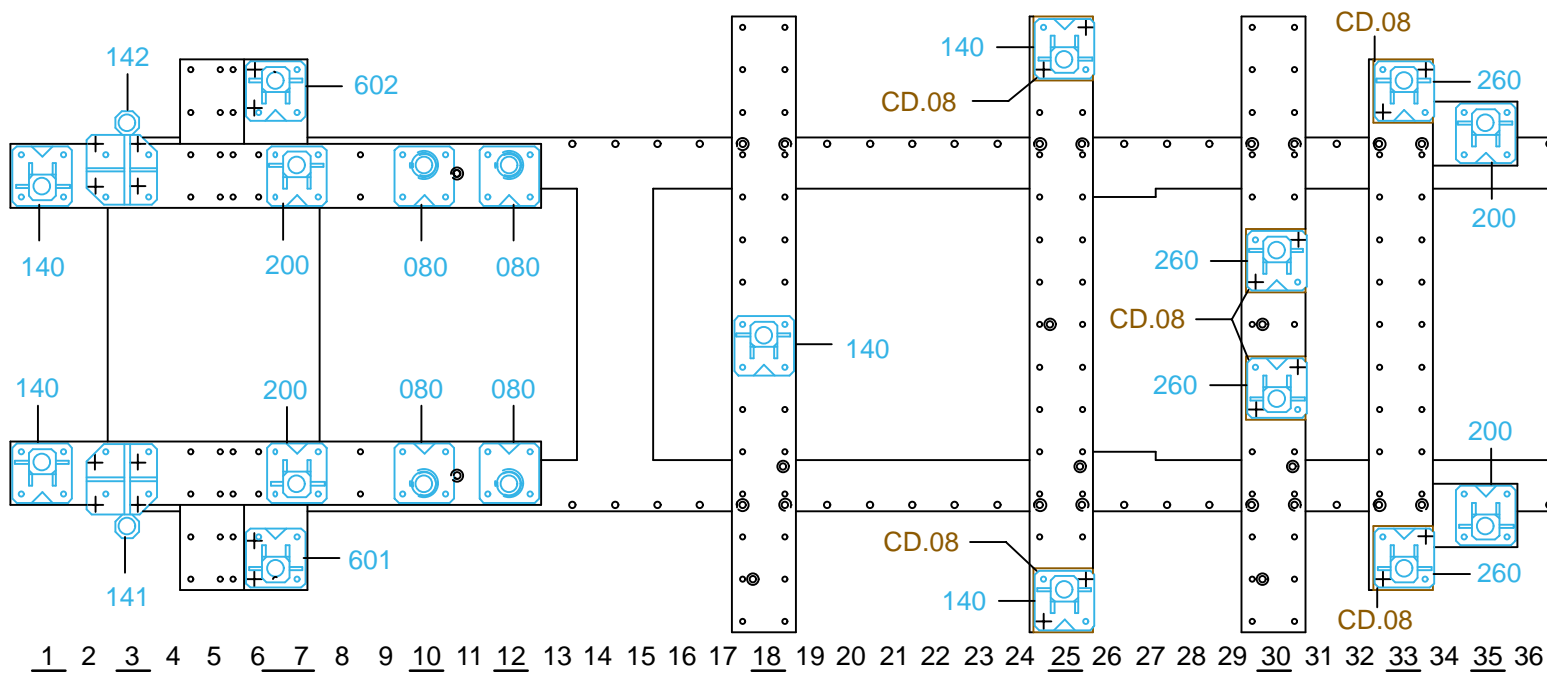



5 Portes  
5 -Türig  
5 Door  
5 Porte  
5 Puertas

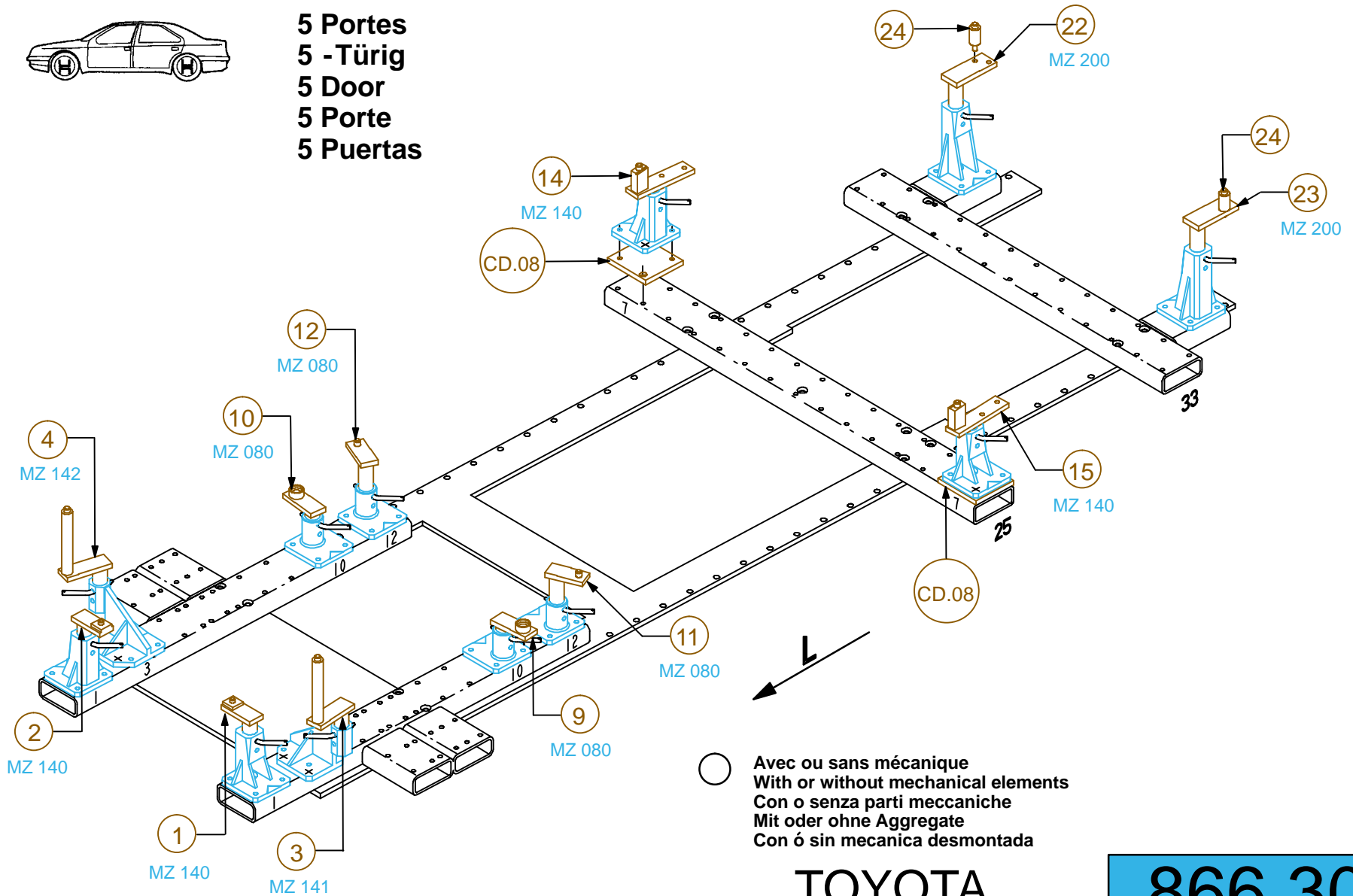

**TOYOTA**

**866.300**

69 Kg | 07.03.2001 | 434-D-75D

