

A4 quattro

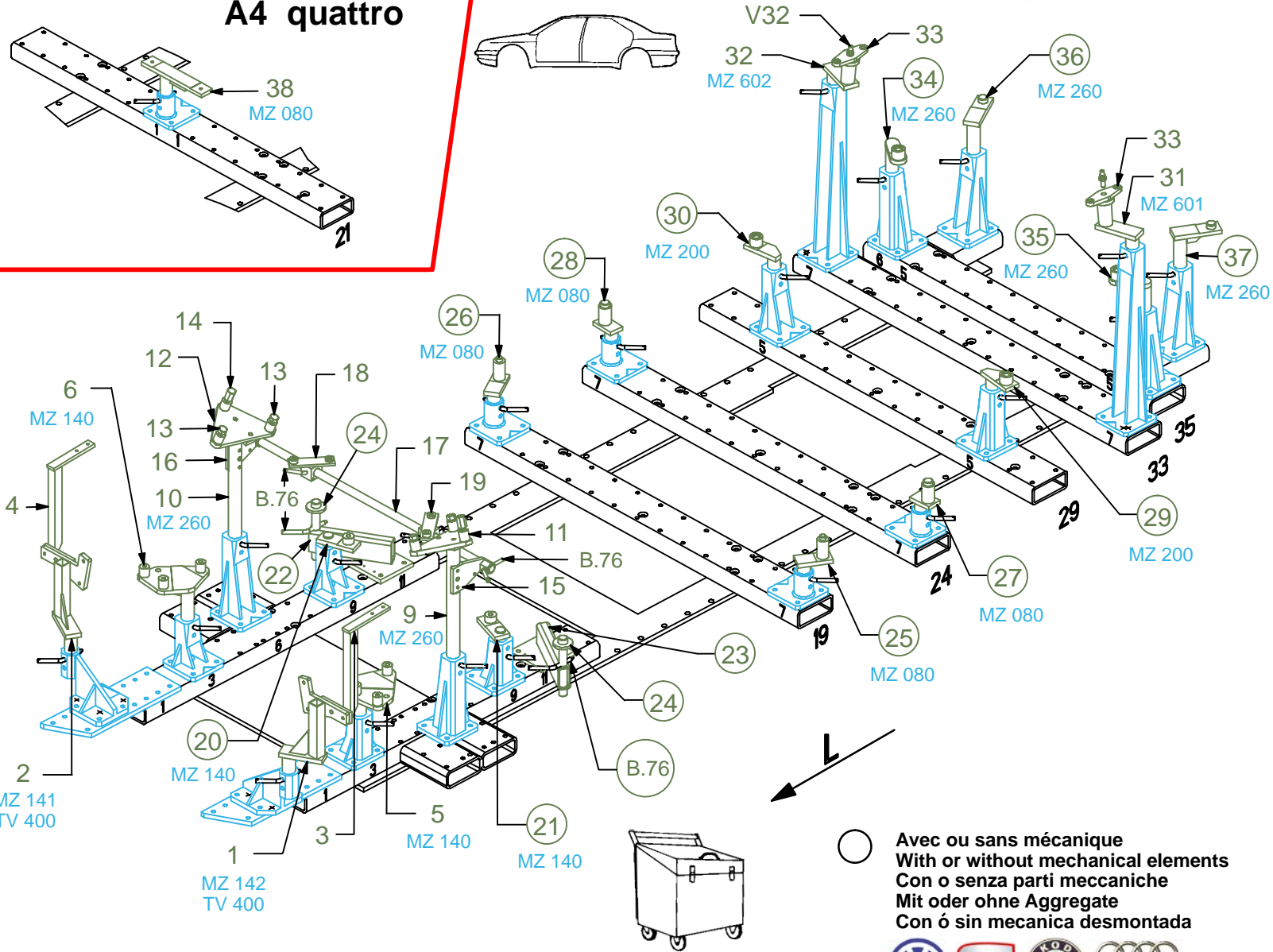

VAS 6042 = 861.300 + VAG1646.25



REP.	REFERENCE	PDS	NB	MZ
1	861.7001	3,9	1	142
2	861.7002	3,9	1	141
3	861.7003	1,6	1	
4	861.7004	1,6	1	
5	861.7005	4,8	1	140
6	861.7006	4,8	1	140
7	861.7007	2,2	1	080
8	861.7008	2,2	1	080
9	861.7009	4,9	1	260
10	861.7010	4,9	1	260
11	861.7011	2,6	1	
12	861.7012	2,6	1	
13	861.7013	0,1	4	
14	861.7014	0,2	2	
15	861.7015	0,9	1	
16	861.7016	0,9	1	
17	861.7017	4,0	1	
18	861.7018	1,0	1	
19	861.7019	1,0	1	
20	861.7020	1,6	1	140/080
21	861.7021	1,6	1	140/080
22	861.7022	4,0	1	
23	861.7023	4,0	1	
24	861.7024	1,0	2	
25	861.7025	2,0	1	080
26	861.7026	2,0	1	080
27	861.7027	2,0	1	080
28	861.7028	2,0	1	080
29	861.7029	1,9	1	200/140
30	861.7030	1,9	1	200/140
31	861.7031	2,2	1	601
32	861.7032	2,2	1	602
33	861.7033	0,4	2	
34	861.7034	2,3	1	260/200
35	861.7035	2,3	1	260/200
36	861.7036	2,7	1	260
37	861.7037	2,7	1	260
38	861.7038	3,0	1	080
	V32	0,1	2	
	B76	0,1	6	

M 6-25	4
M 8-16	4
M 8-25	6
M 10-30	2
M 10-35	2
M 10-60	4
M 12-25	6
M 12x1,50-60	2
M 12x1,50-70	2
M 12x1,50-80	4
M 12x1,50-120	2
M 12x1,50-130	2
M 12x1,50-150	4
M 10	2
MU 12	2

○ Avec ou sans mécanique
With or without mechanical elements
Con o senza parti meccaniche
Mit oder ohne Aggregate
Con ó sin mecanica desmontada

861.300

94 Kg 18.09.2000 403-D-15A

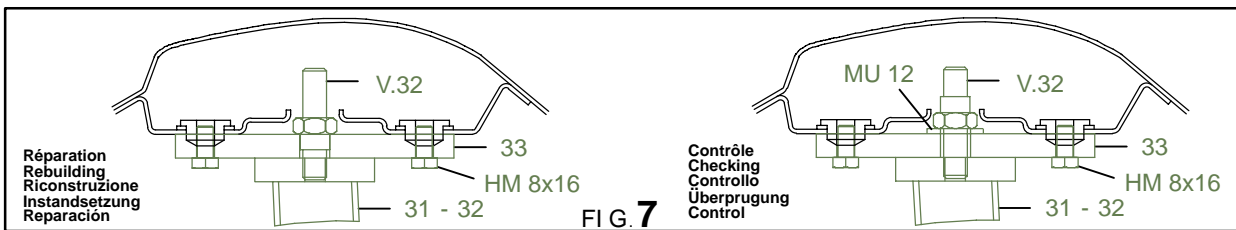
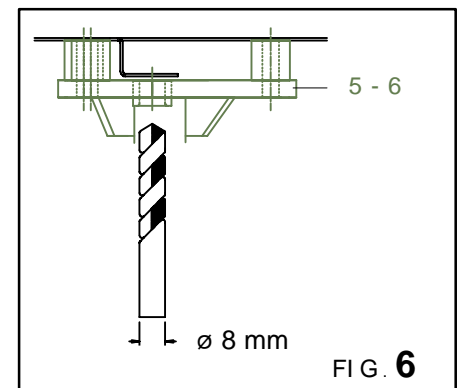
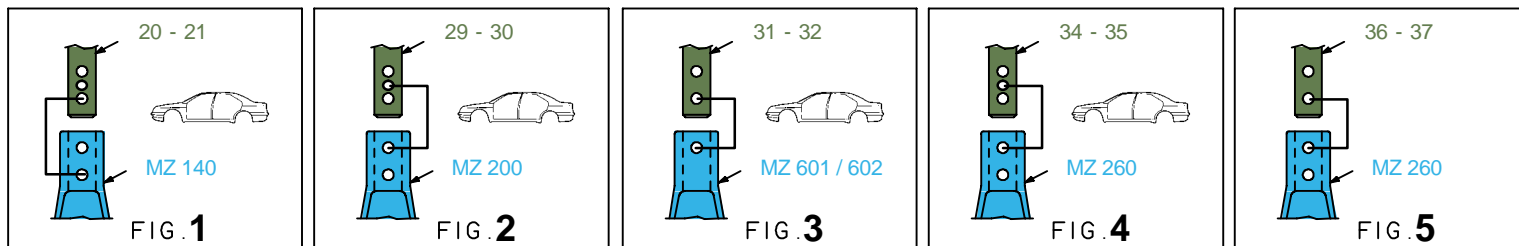
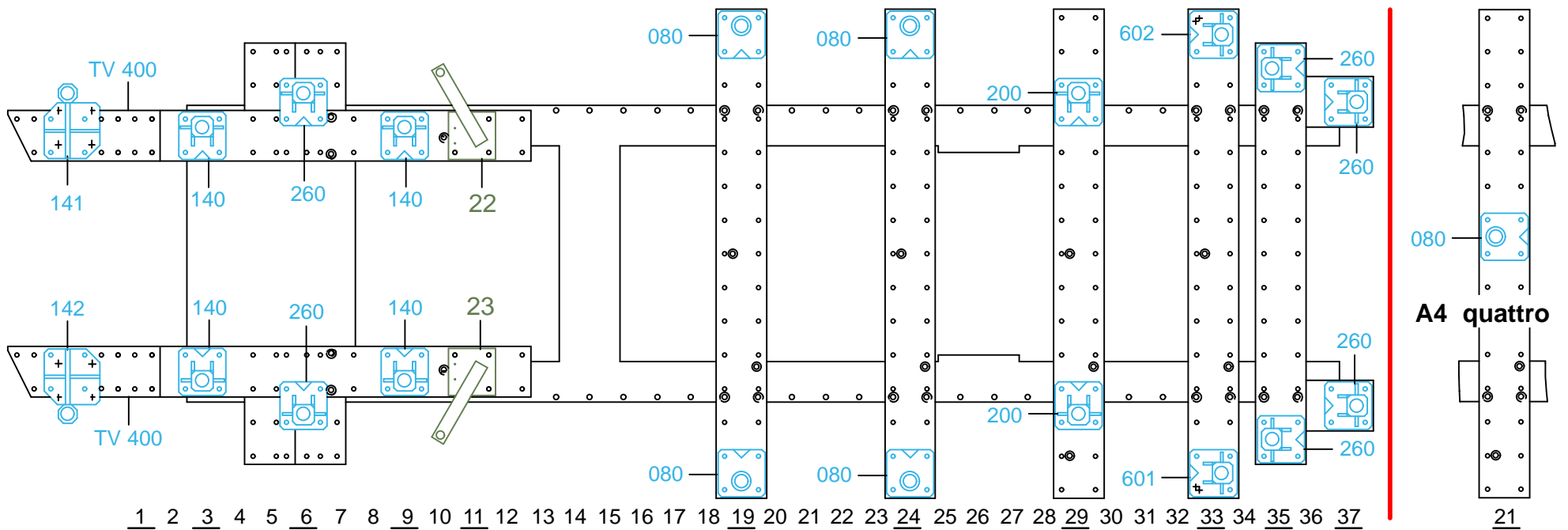

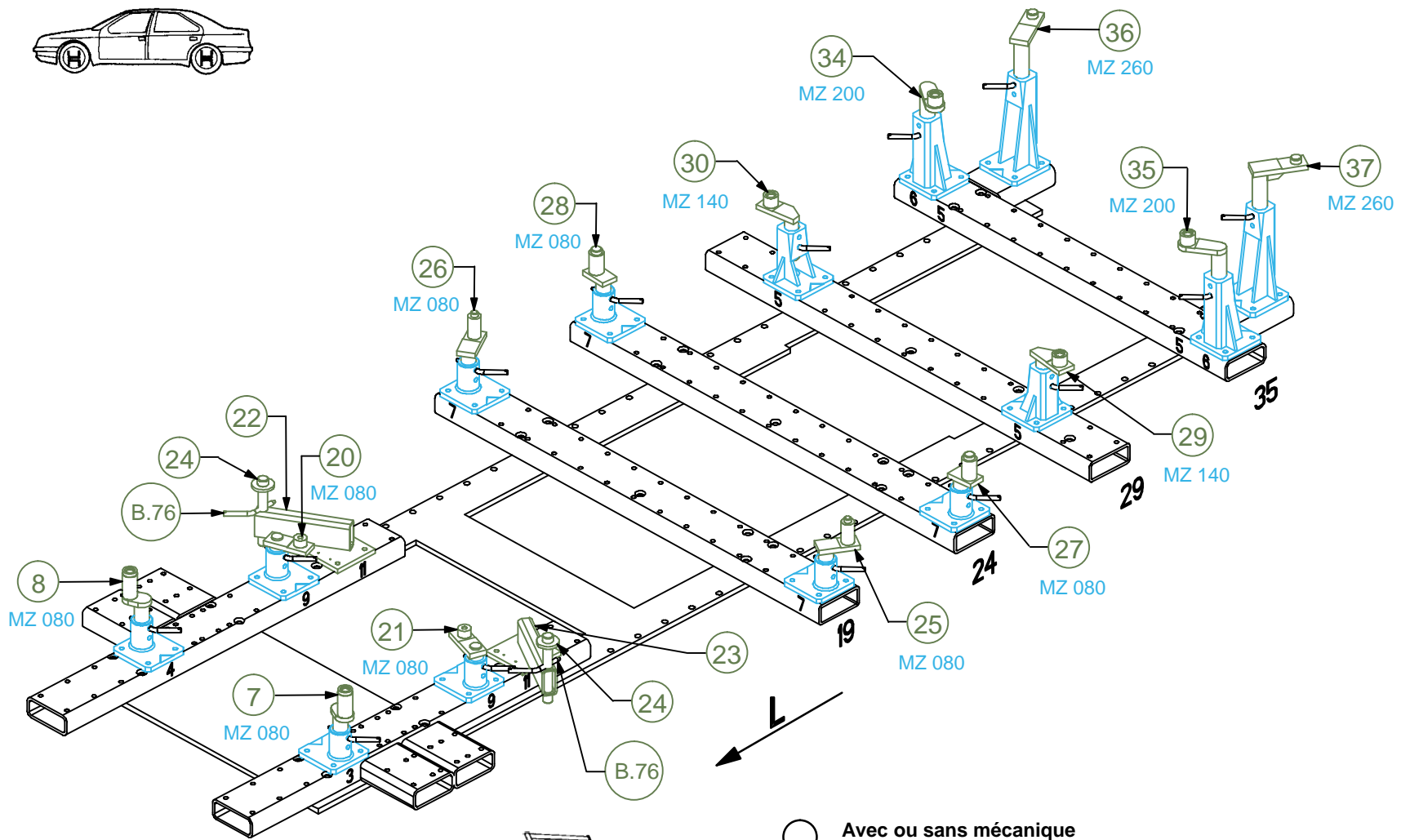
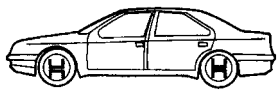

○ Avec ou sans mécanique
With or without mechanical elements
Con o senza parti meccaniche
Mit oder ohne Aggregate
Con ó sin mecanica desmontada

VAS 6042 = 861.300 + VAG1646.25



861.300

94 Kg | 18.09.2000 | 403-D-15B

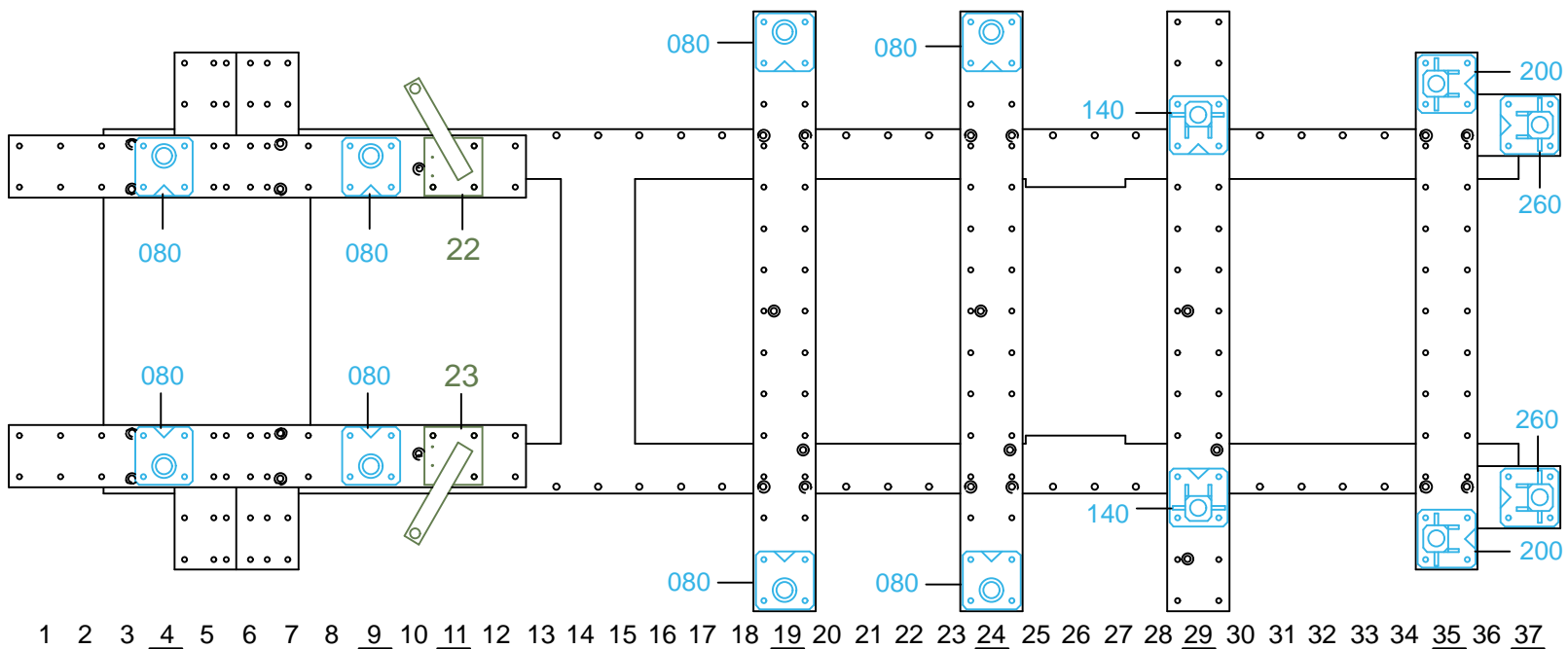

1 2 3 4 5 6 7 8 9 10 11 12 13 14 15 16 17 18 19 20 21 22 23 24 25 26 27 28 29 30 31 32 33 34 35 36 37

