

**SONATA EF
OPTIMA**

REP.	MOD.
17 - 18	→ 07.2000

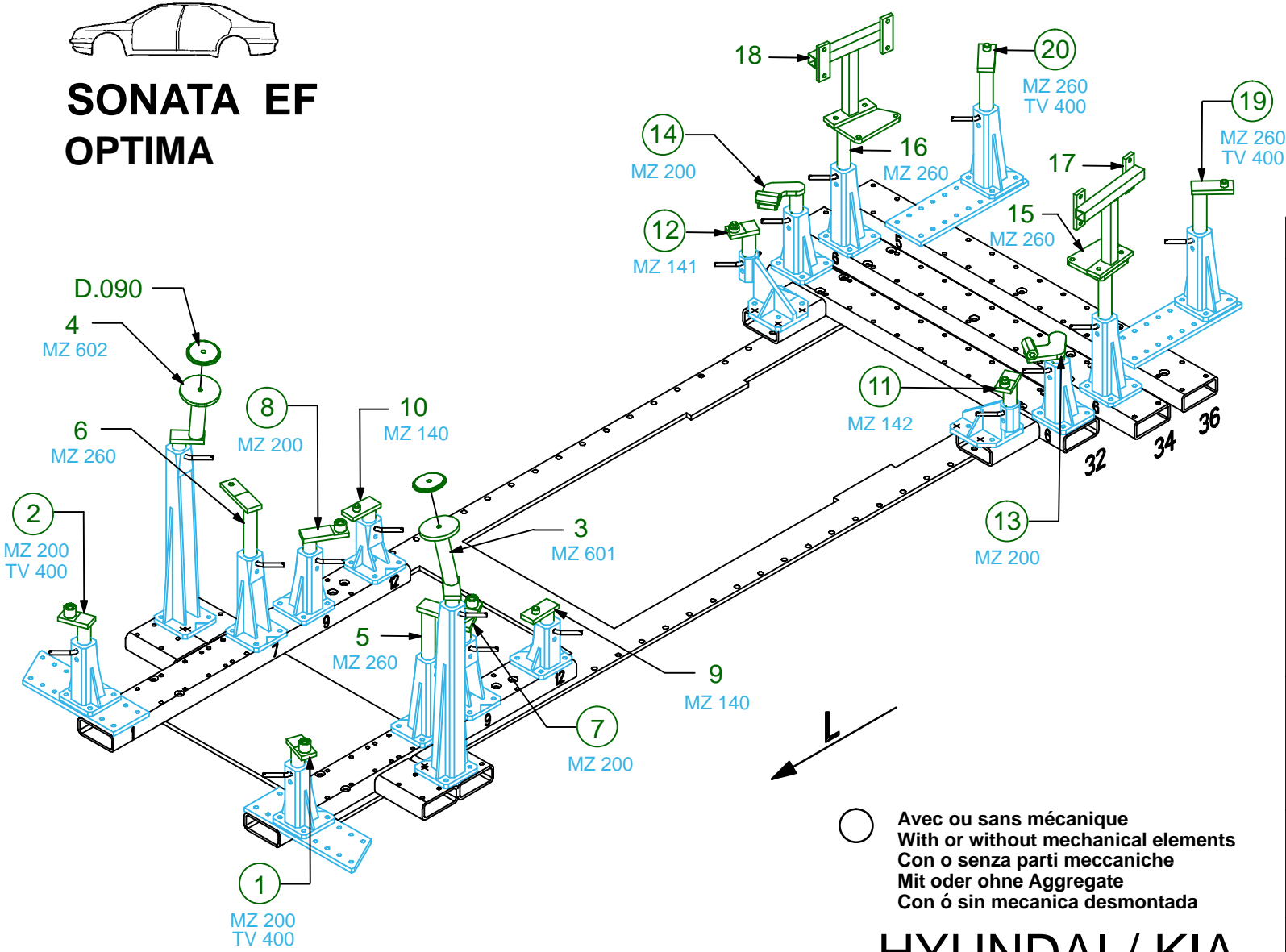

REP.	REFERENCE	PDS	NB	MZ
1	854.7001	2,0	1	200/140
2	854.7002	2,0	1	200/140
3	854.7003	3,1	1	601
4	854.7004	3,1	1	602
5	854.7005	3,1	1	260
6	854.7006	3,1	1	260
7	854.7007	1,9	1	200/140
8	854.7008	1,9	1	200/140
9	854.7009	1,7	1	140
10	854.7010	1,7	1	140
11	854.7011	1,9	1	141/142
12	854.7012	1,9	1	141/142
13	854.7013	2,9	1	200
14	854.7014	2,9	1	200
15	854.7015	4,6	1	260
16	854.7016	4,6	1	260
17	854.7017	3,1	1	
18	854.7018	3,1	1	
19	854.7019	2,8	1	260
20	854.7020	2,8	1	260
	D.090	0,6	2	

M 12-25	6
M 10x1,25-25	8
M 12x1,25-50	4
M 12x1,25-60	2
M 12x1,25-70	2
M 12x1,25-130	4
M 14x1,50-60	2

○ Avec ou sans mécanique
With or without mechanical elements
Con o senza parti meccaniche
Mit oder ohne Aggregate
Con ó sin mecanica desmontada

HYUNDAI / KIA

854.300

57 Kg 05.11.2002 447-D-11A

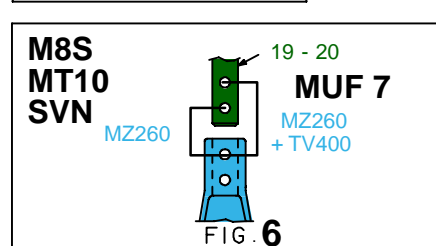
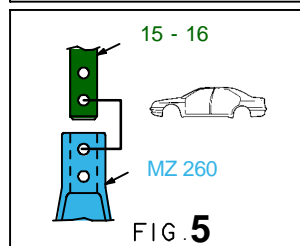
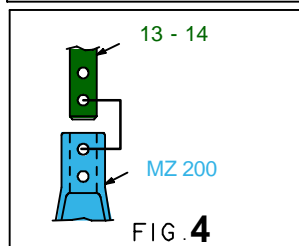
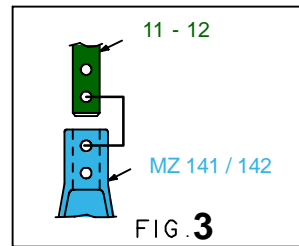
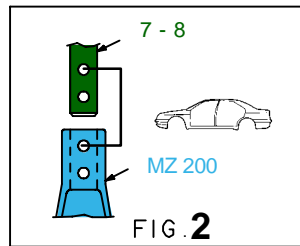
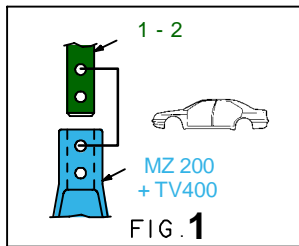
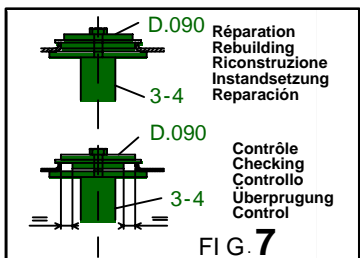
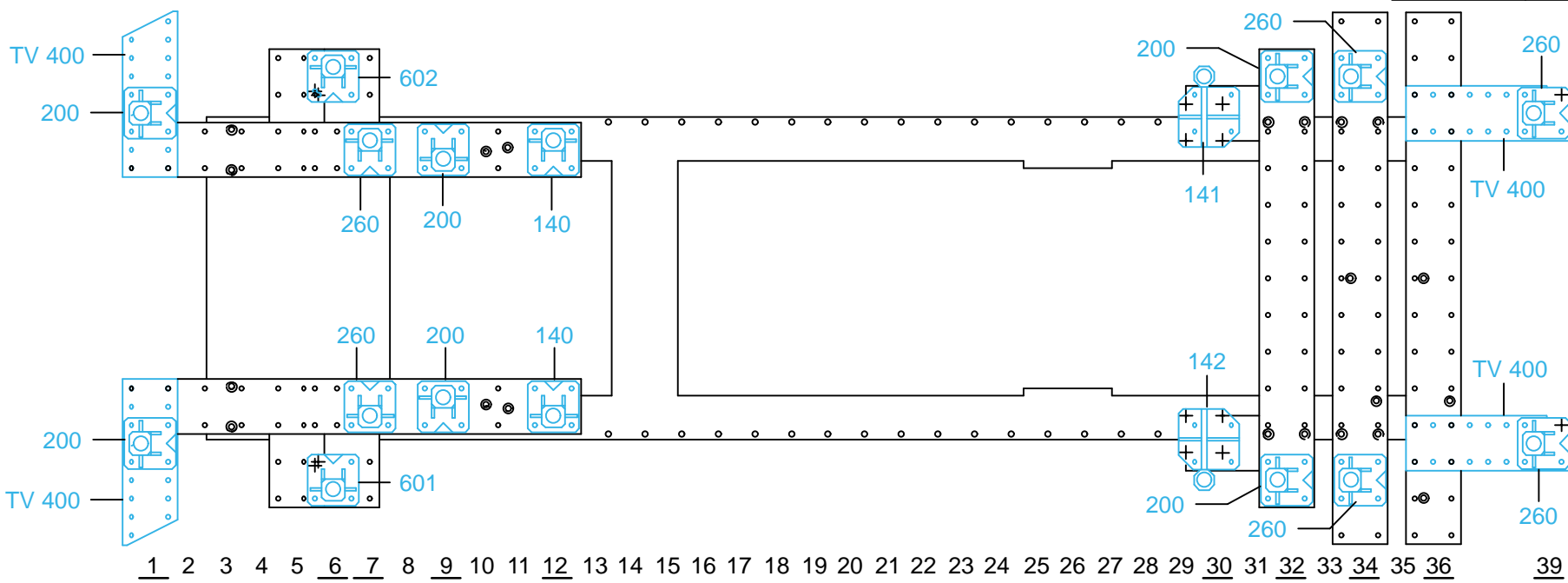

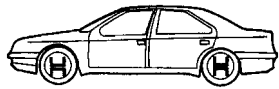

**SONATA EF
OPTIMA**

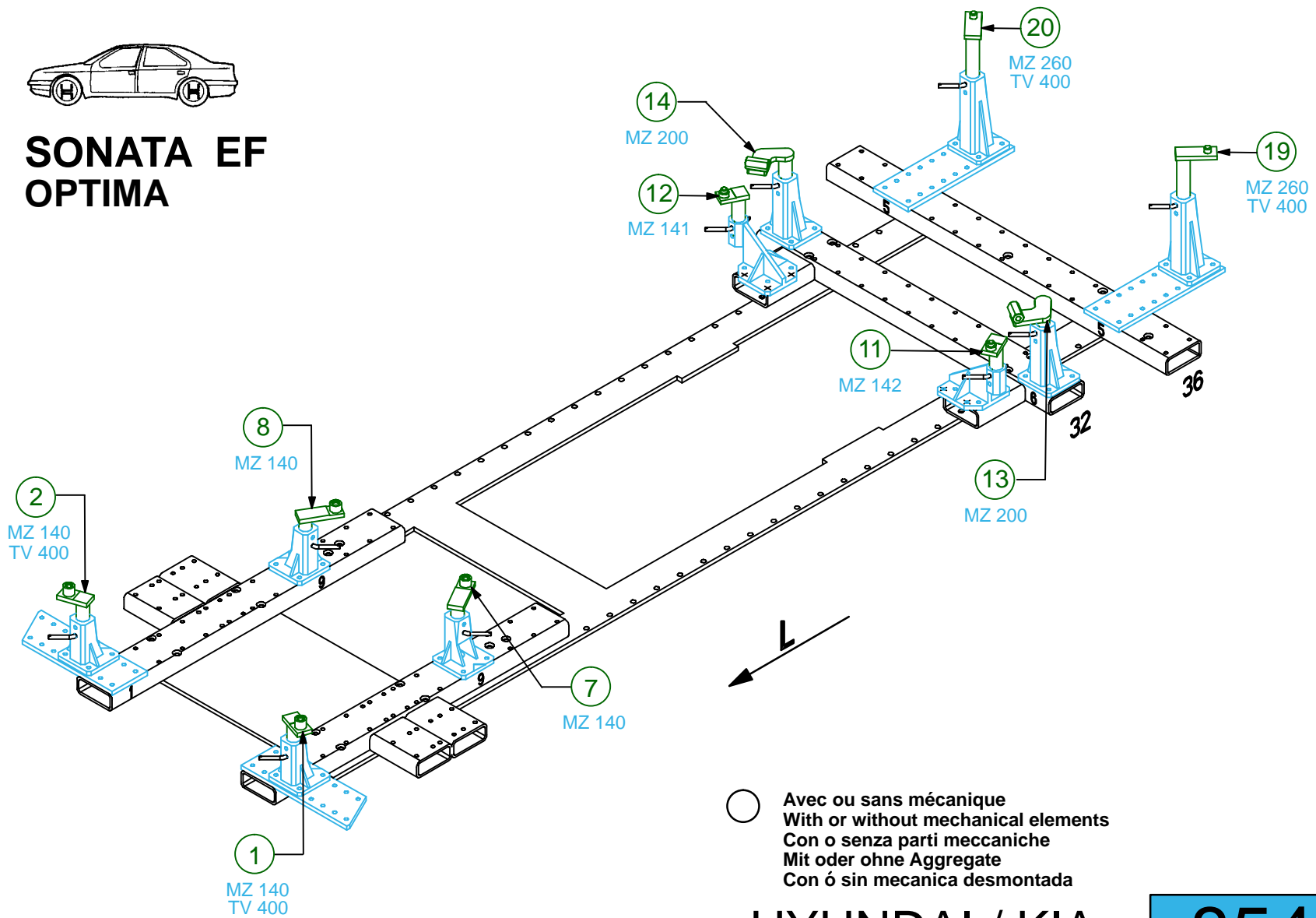

HYUNDAI / KIA

854.300

57 Kg | 05.11.2002 | 447-D-11B

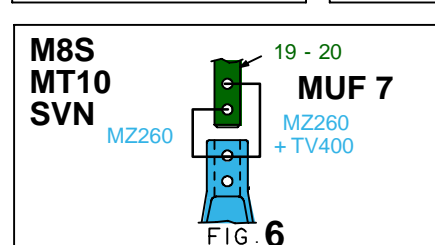
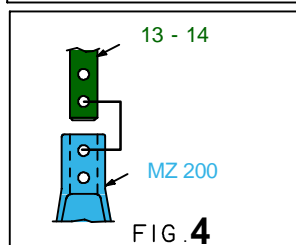
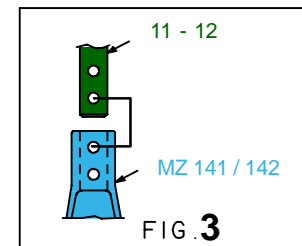
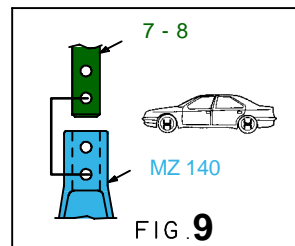
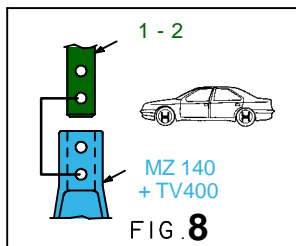
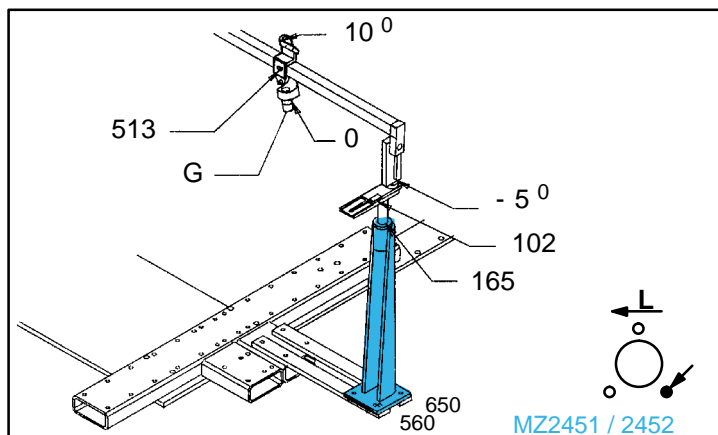
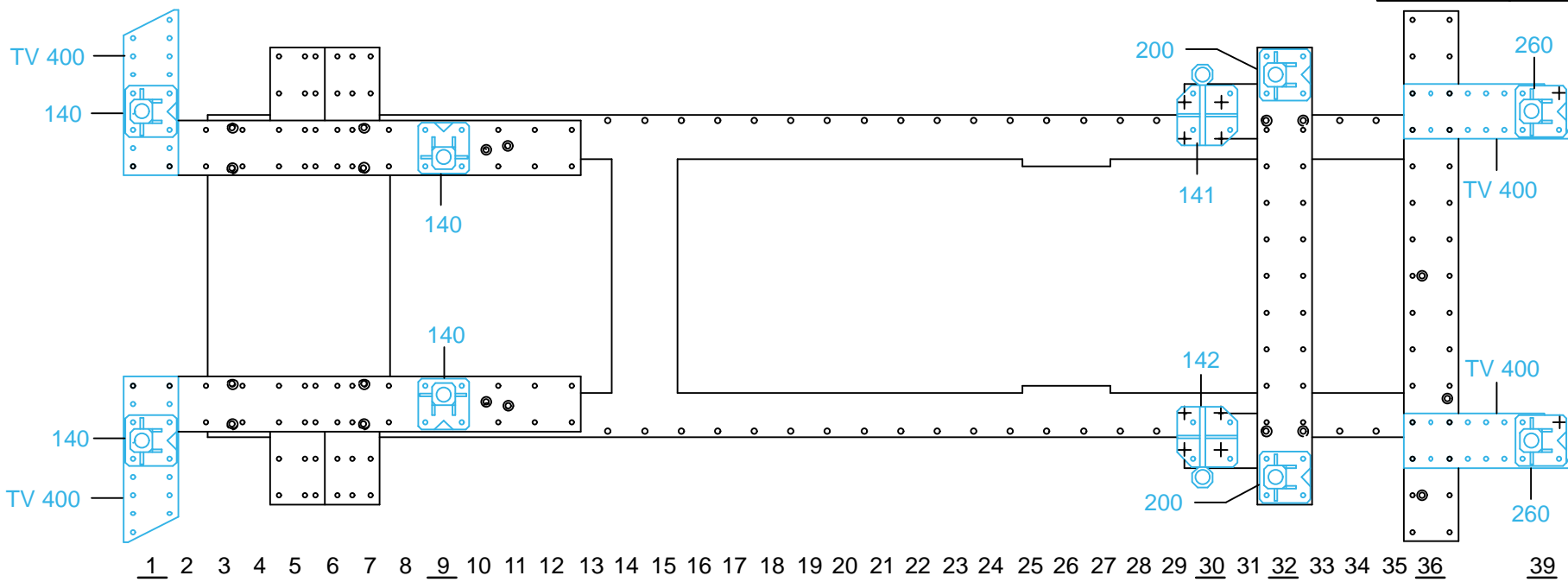



GRANDEUR XG30

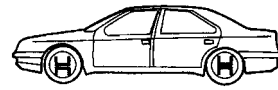
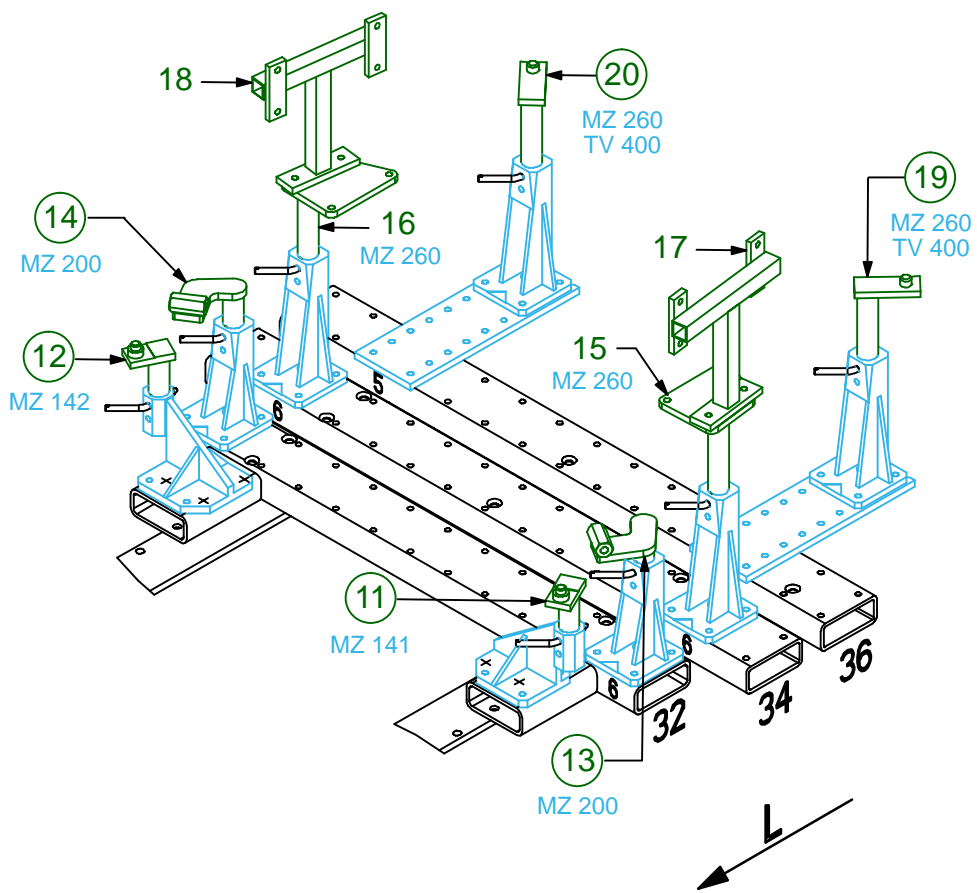

GRANDEUR XG30

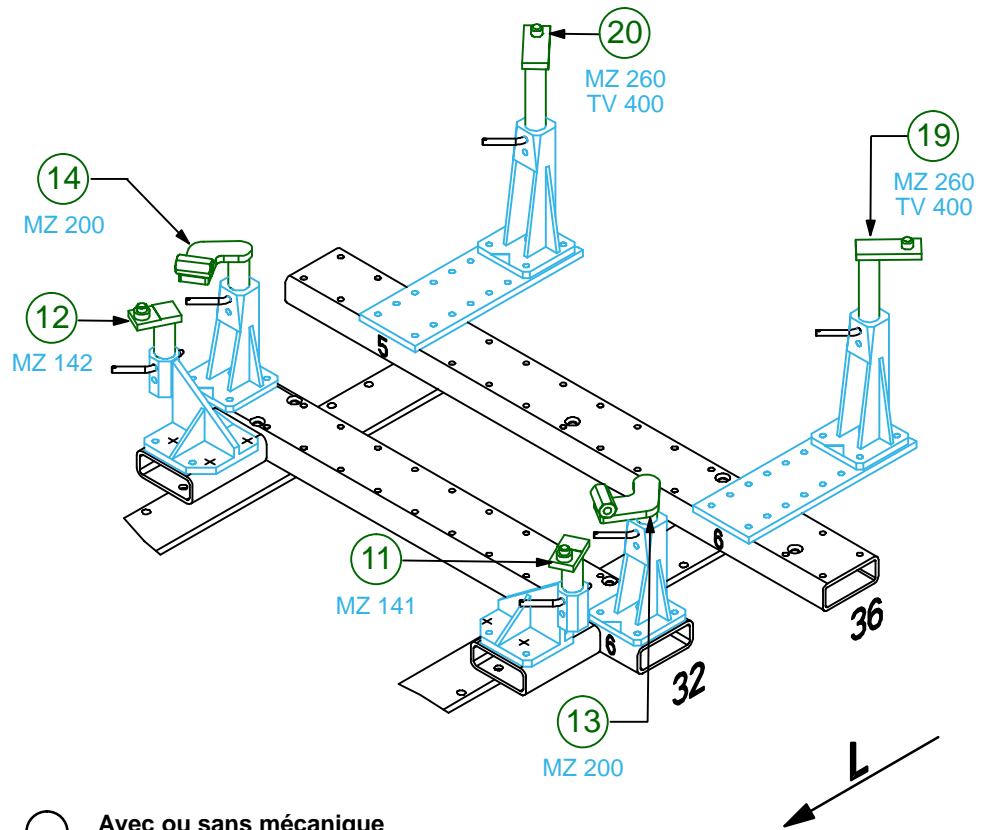

○ Avec ou sans mécanique
With or without mechanical elements
Con o senza parti meccaniche
Mit oder ohne Aggregate
Con ó sin mecánica desmontada

HYUNDAI / KIA

854.300

57 Kg 05.11.2002 447-D-11C

