

REP.	MOD.
35 - 36 + D.100	2WD
41 - 42 + 30	4WD

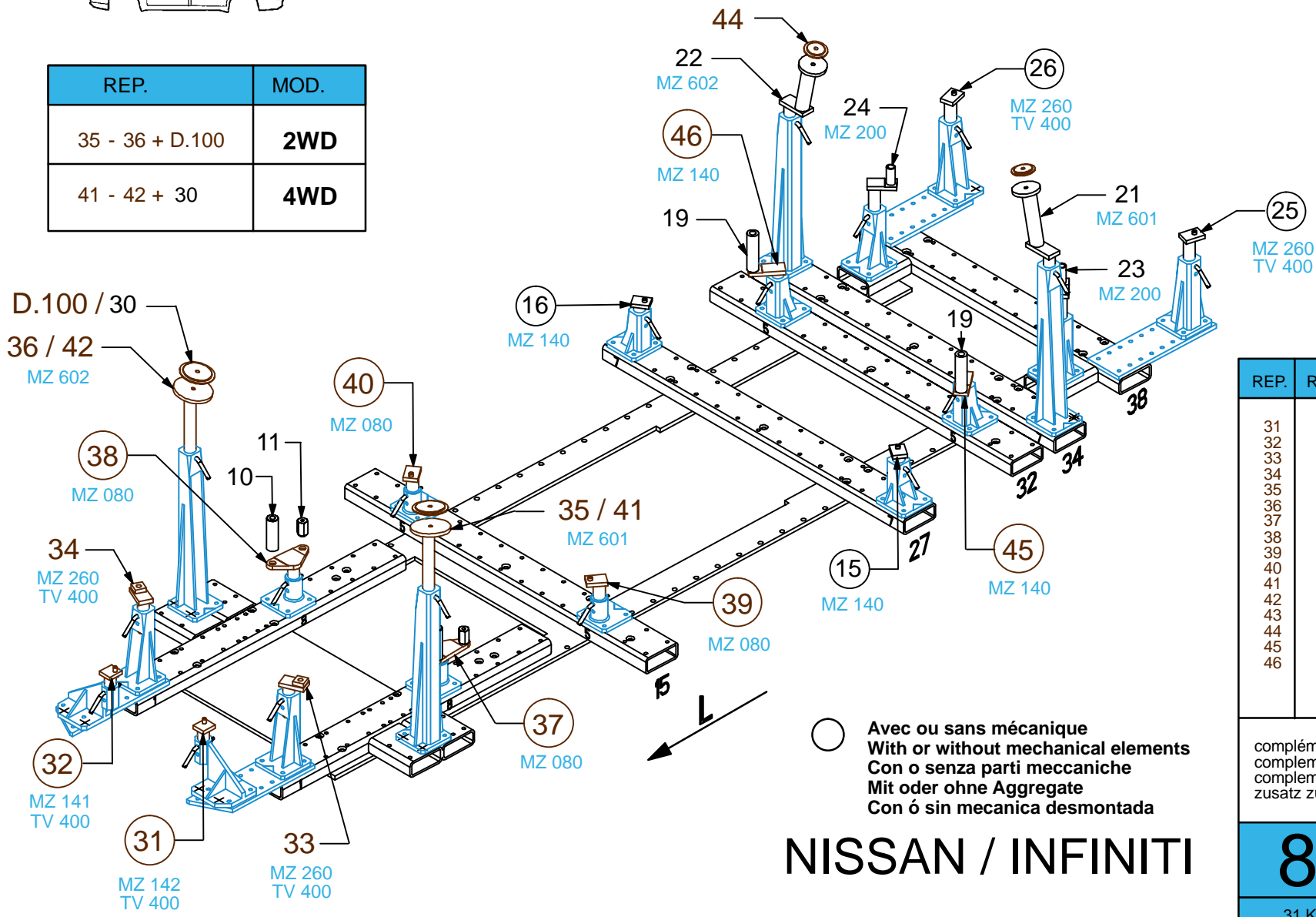

REP.	REFERENCE	PDS	NB	MZ
31	840.7031	1,4	1	142
32	840.7032	1,4	1	141
33	840.7033	1,8	1	260
34	840.7034	1,8	1	260
35	840.7035	2,6	1	601
36	840.7036	2,6	1	602
37	840.7037	2,2	1	080
38	840.7038	2,2	1	080
39	840.7039	1,6	1	080
40	840.7040	1,6	1	080
41	840.7041	2,6	1	601
42	840.7042	2,6	1	602
43	840.7043	0,4	2	
44	840.7044	0,3	2	
45	840.7045	1,8	1	140/080
46	840.7046	1,8	1	140/080
	D.100	0,8	2	

complément au
complementary set to
complemento al
zusatz zu **840.310**

840.309

31 Kg 27.05.2005 410-D-64E

NISSAN / INFINITI

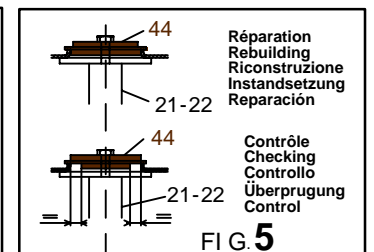
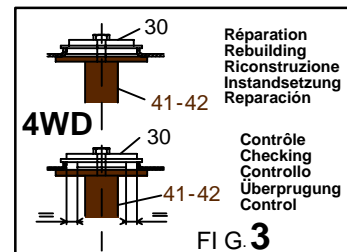
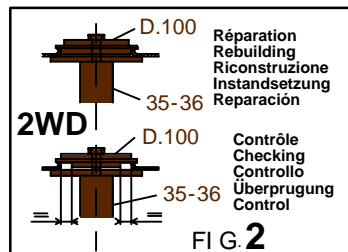
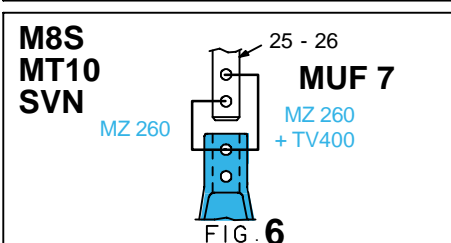
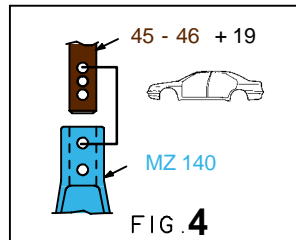
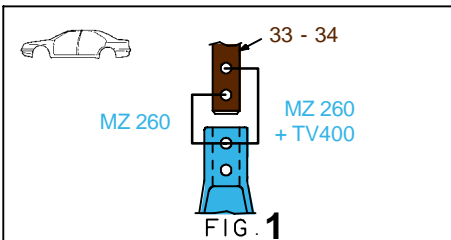
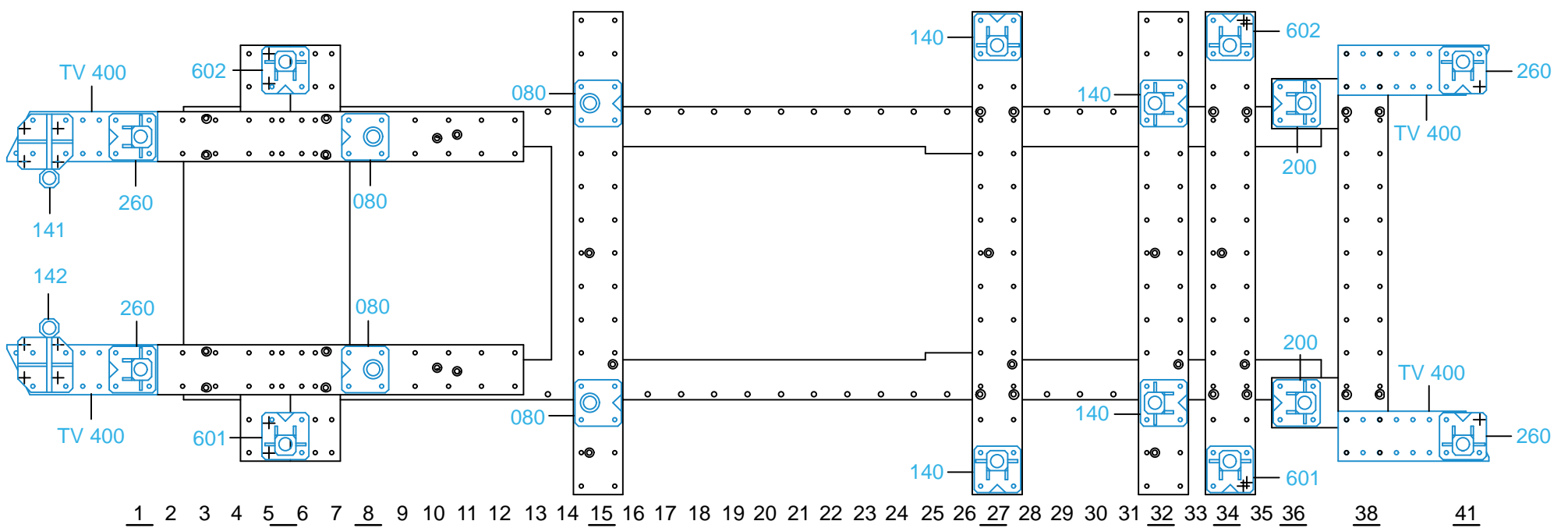

840.309-RVA3-1 00

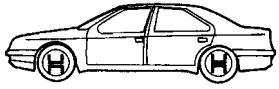

REP.	MOD.
45 - 46 + 20	2WD
45 - 46 + 43	4WD

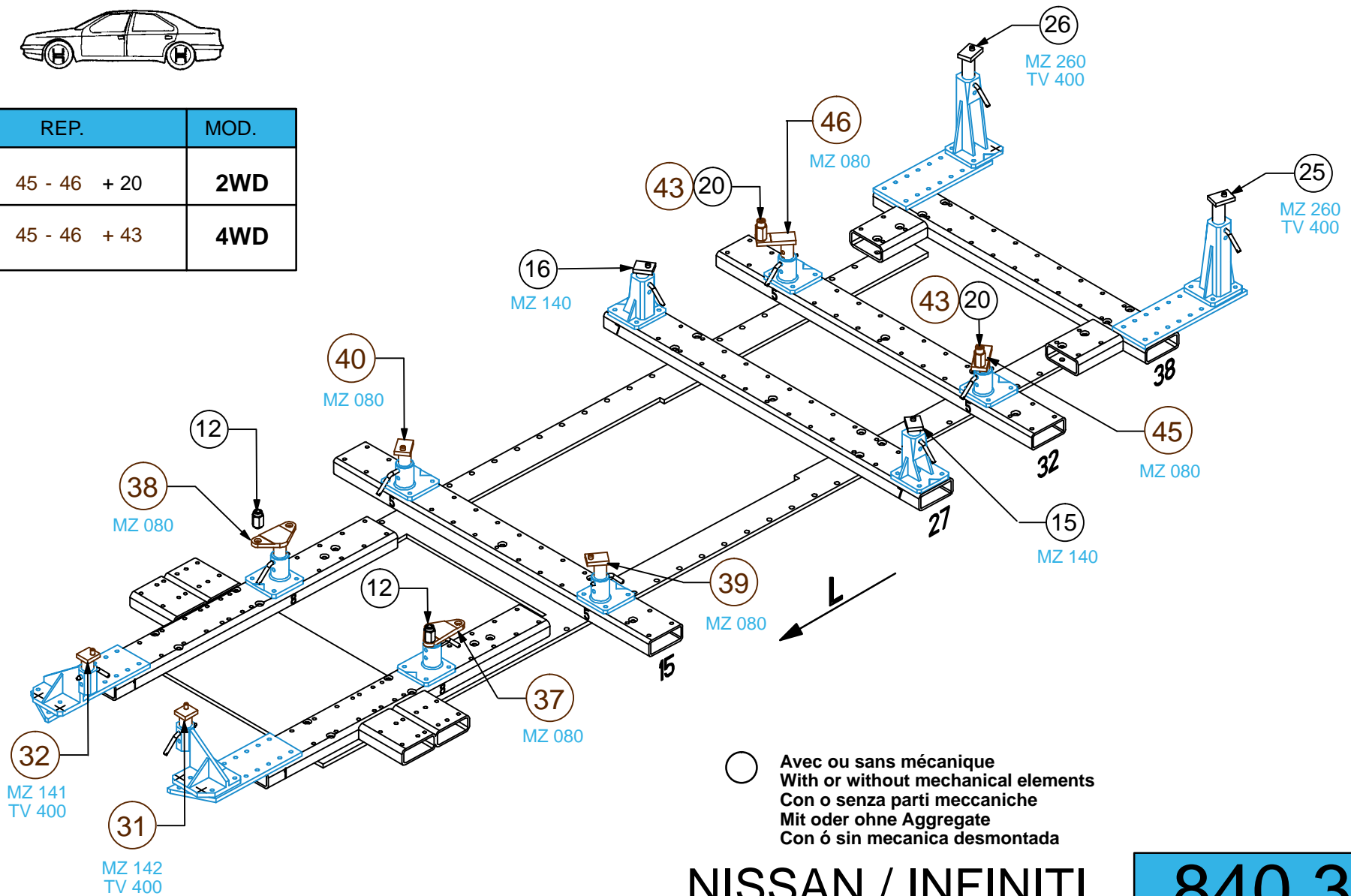

○ Avec ou sans mécanique
With or without mechanical elements
Con o senza parti meccaniche
Mit oder ohne Aggregate
Con ó sin mecánica desmontada

NISSAN / INFINITI

840.309

31 Kg | 27.05.2005 | 410-D-64F

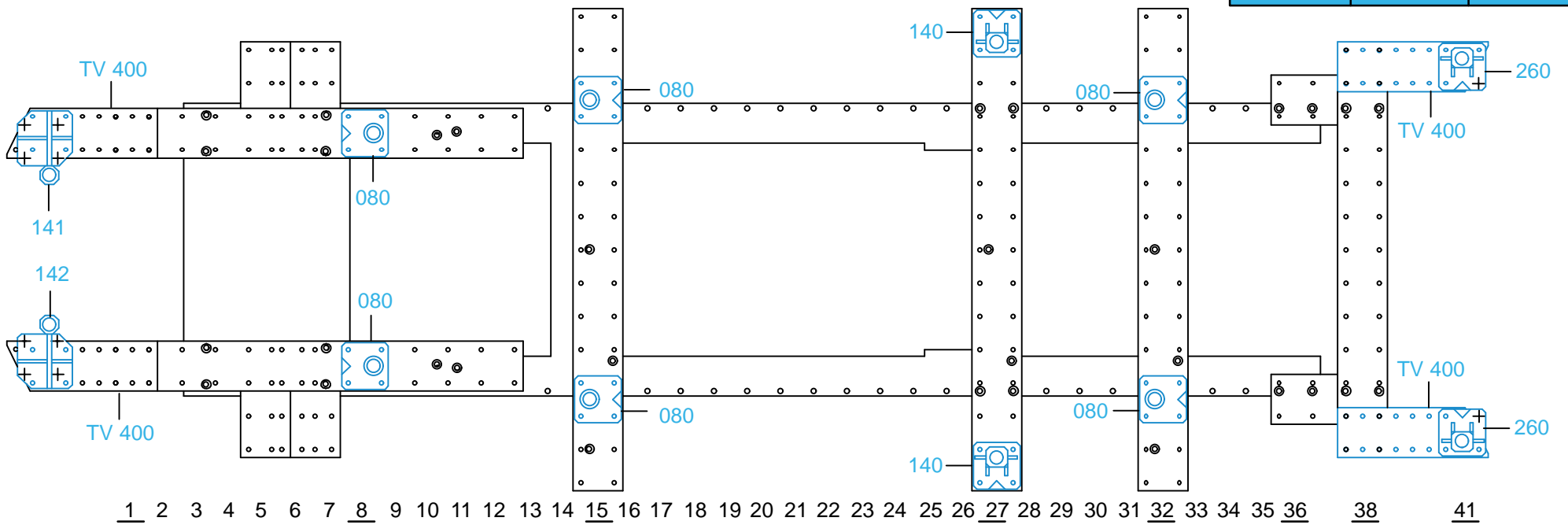

1 2 3 4 5 6 7 8 9 10 11 12 13 14 15 16 17 18 19 20 21 22 23 24 25 26 27 28 29 30 31 32 33 34 35 36 38 41

