

4 Portes
4 Door
4 -Türig
4 Porte
4 Puertas

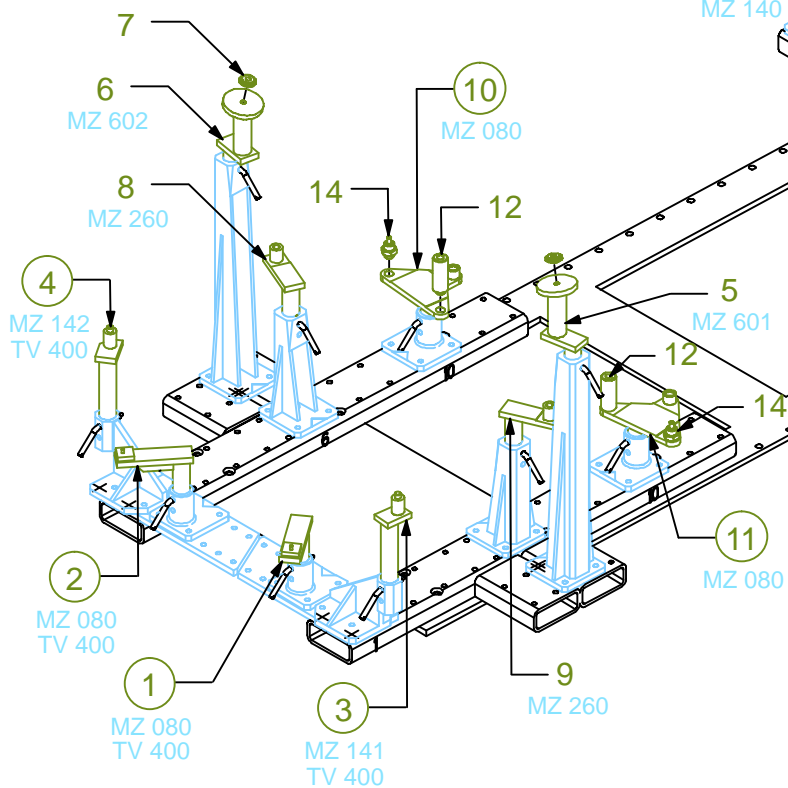
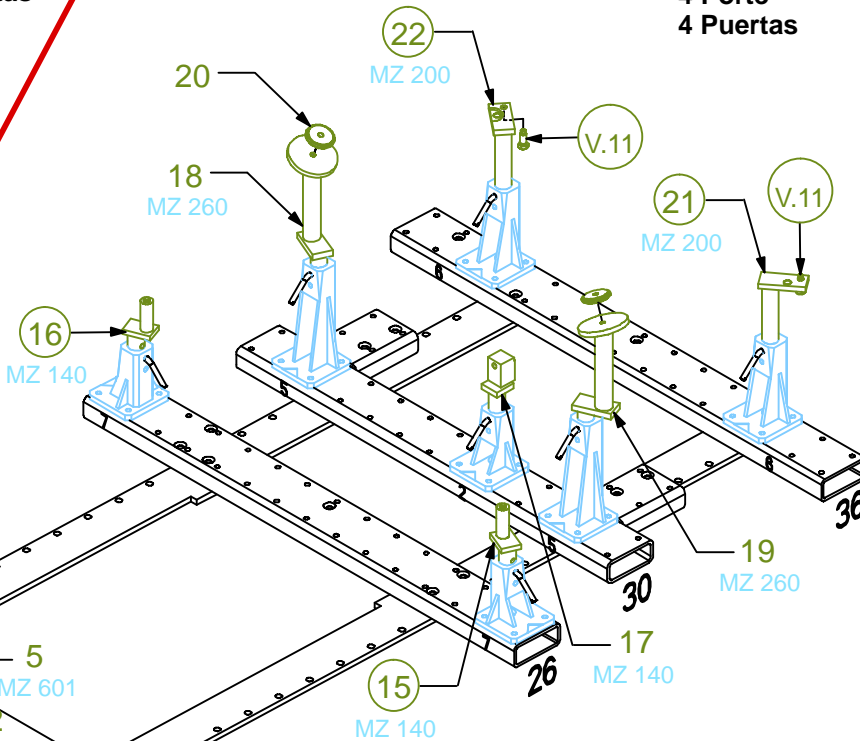

○ Avec ou sans mécanique
With or without mechanical elements
Con o senza parti meccaniche
Mit oder ohne Aggregate
Con ó sin mecanica desmontada

NISSAN

REP.	REFERENCE	PDS	NB	MZ
1	831.7001	2,6	1	080
2	831.7002	2,9	1	080
3	831.7003	3,0	1	141
4	831.7004	3,0	1	142
5	831.7005	2,6	1	601
6	831.7006	2,6	1	602
7	831.7007	0,1	2	
8	831.7008	2,5	1	260
9	831.7009	2,5	1	260
10	831.7010	3,2	1	080
11	831.7011	3,2	1	080
12	831.7012	0,6	2	
13	831.7013	0,2	2	
14	831.7014	0,2	2	
15	831.7015	1,6	1	140
16	831.7016	1,6	1	140
17	831.7017	2,5	1	140
18	831.7018	3,2	1	260
19	831.7019	3,2	1	260
20	831.7020	0,3	2	
21	831.7021	2,7	1	200
22	831.7022	2,7	1	200
	D.048	0,2	2	
	V.11	0,1	2	
	V.26	0,1	2	

	M 12-25 M 10x1,25-60 M 12x1,25-20	4 2 4
	LU 12	4

831.300

50 Kg 25.04.2000 410-D-63A

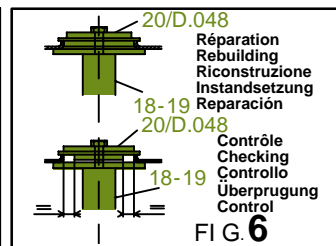
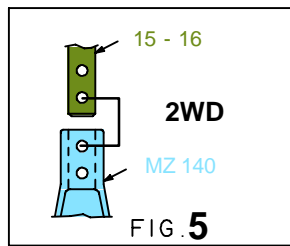
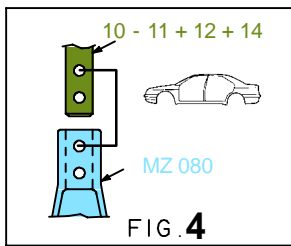
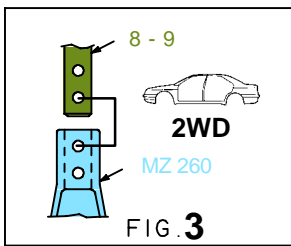
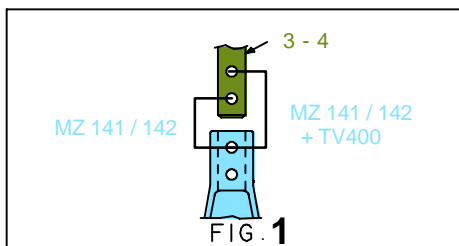
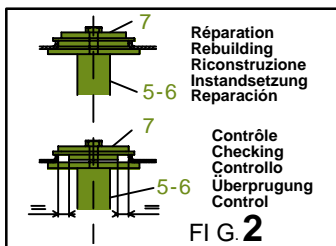
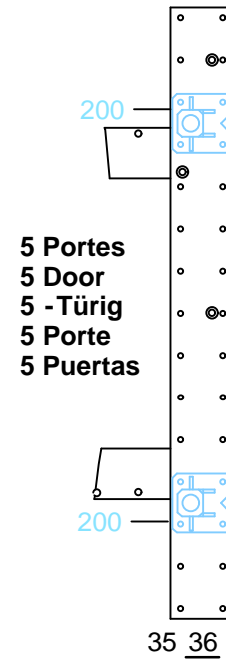
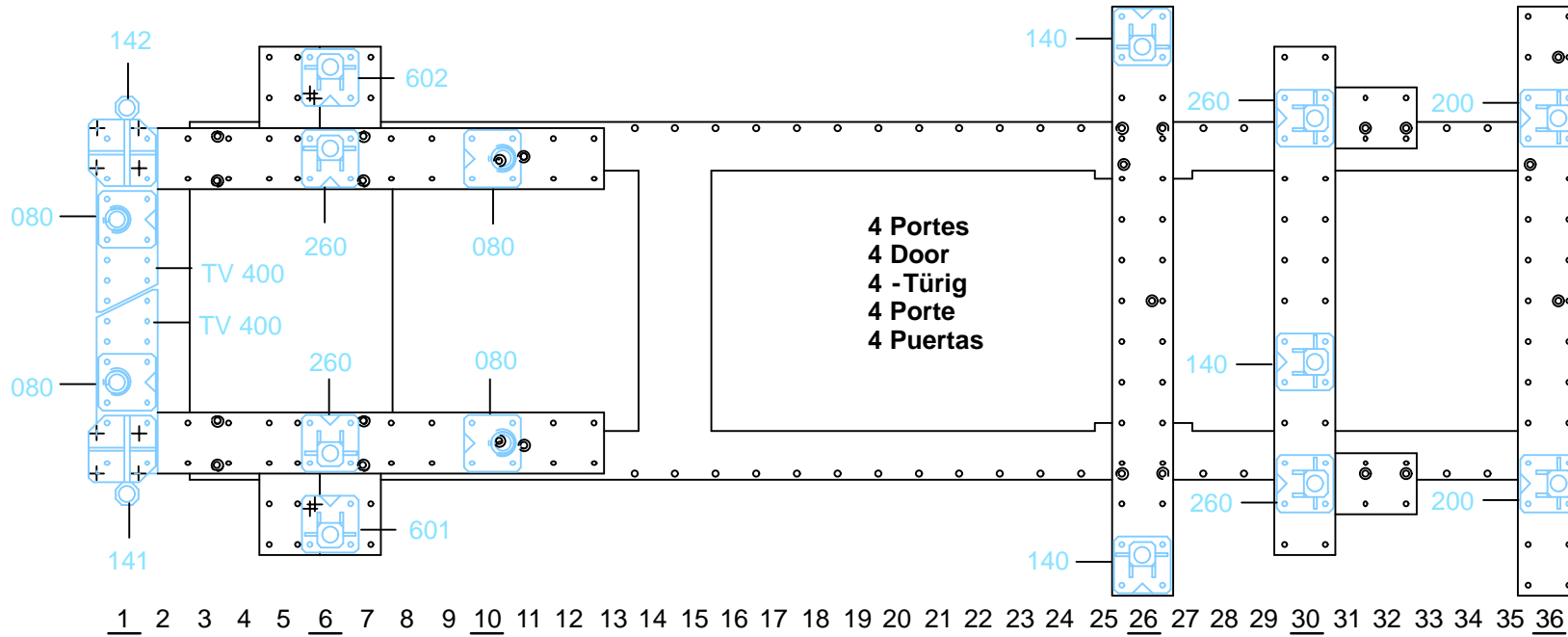

5 Portes
 5 Door
 5 -Türig
 5 Porte
 5 Puertas

4 Portes
 4 Door
 4 -Türig
 4 Porte
 4 Puertas

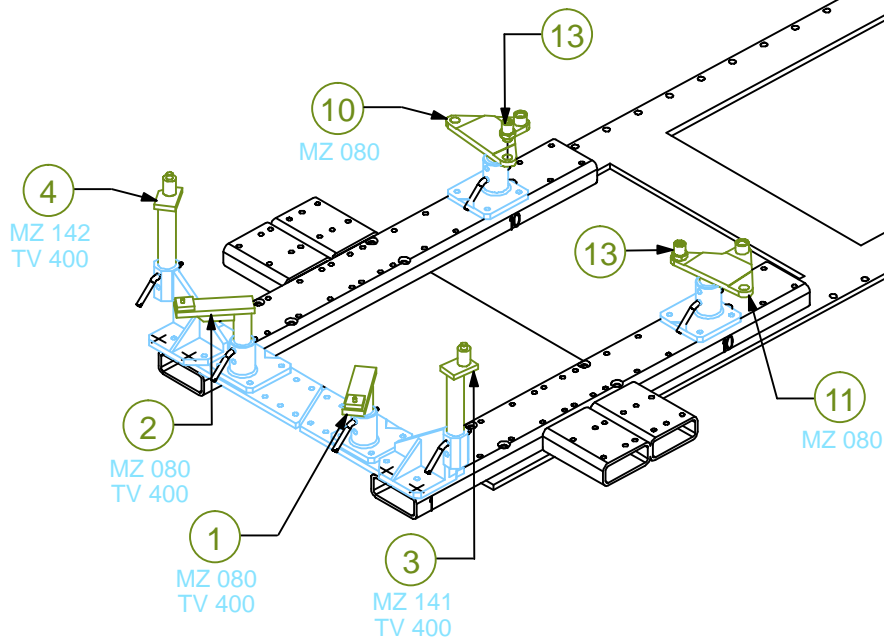
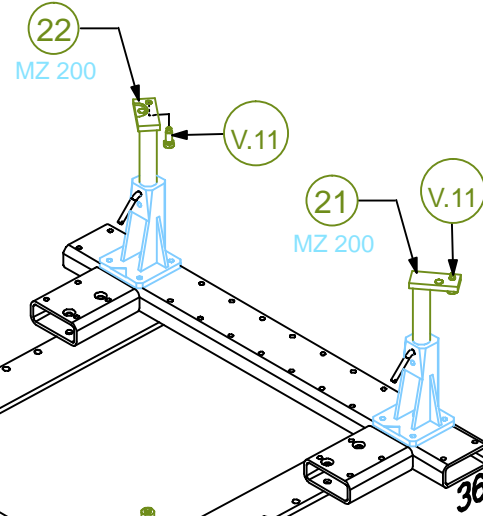
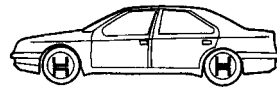
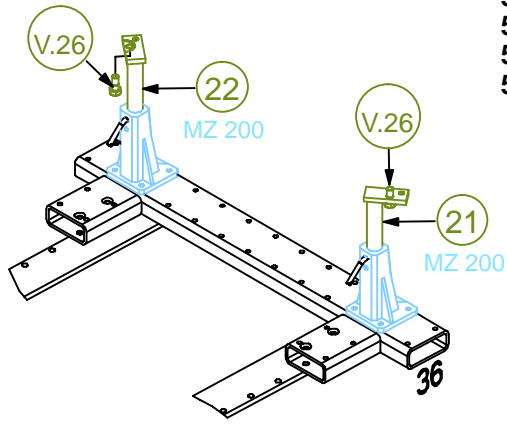

○ Avec ou sans mécanique
 With or without mechanical elements
 Con o senza parti meccaniche
 Mit oder ohne Aggregate
 Con ó sin mecánica desmontada

NISSAN

831.300

50 Kg | 01.02.2000 | 410-D-63B

