

○ Avec ou sans mécanique
With or without mechanical elements
Con o senza parti meccaniche
Mit oder ohne Aggregate
Con ó sin mecanica desmontada

TOYOTA / LEXUS

REP.	REFERENCE	PDS	NB	MZ
1	805.7001	2,2	1	140
2	805.7002	2,2	1	140
3	805.7003	2,5	1	142
4	805.7004	2,5	1	141
5	805.7005	0,5	4	
6	805.7006	3,4	1	602
7	805.7007	3,4	1	601
8	805.7008	0,5	2	
9	805.7009	1,8	1	080
10	805.7010	1,8	1	080
11	805.7011	2,0	1	080
12	805.7012	2,0	1	080
13	805.7013	2,6	1	080
14	805.7014	2,6	1	080
15	805.7015	1,6	1	200/140
16	805.7016	1,6	1	200/140
17	805.7017	2,5	1	260
18	805.7018	2,5	1	260
19	805.7019	2,0	1	601
20	805.7020	2,0	1	602
21	805.7021	0,7	2	
22	805.7022	3,4	1	200
23	805.7023	3,4	1	200
24	805.7024	2,5	1	260
25	805.7025	2,5	1	260
	V32	0,1	2	

M 8-12	6
M 12-25	2
M 10x1,25-50	6
M 14x1,50-60	2
M 14x1,50-70	4
M 14x1,50-100	4

MU 12	2
-------	---

805.300

58 Kg 09.09.99 434-D-60A

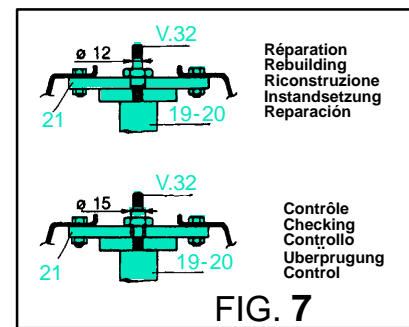
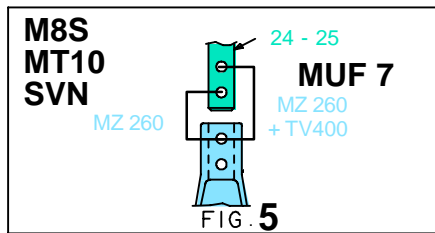
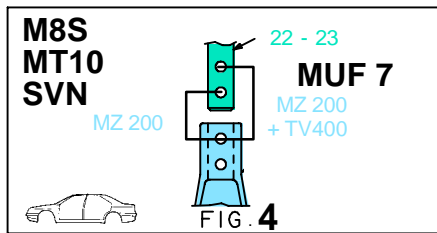
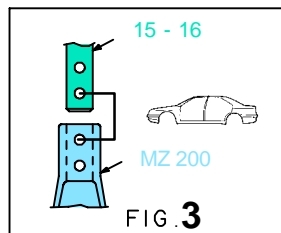
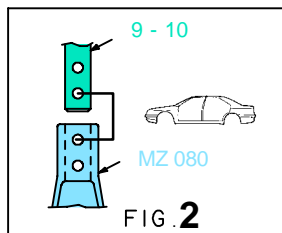
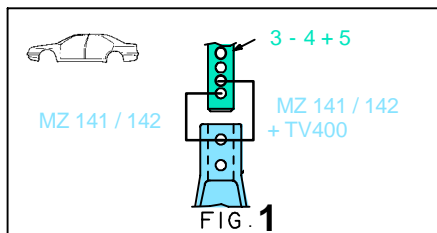
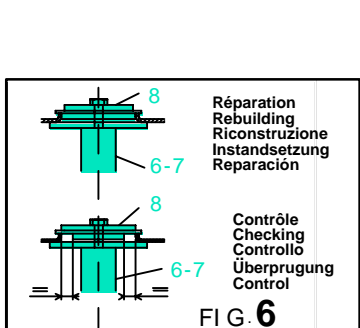
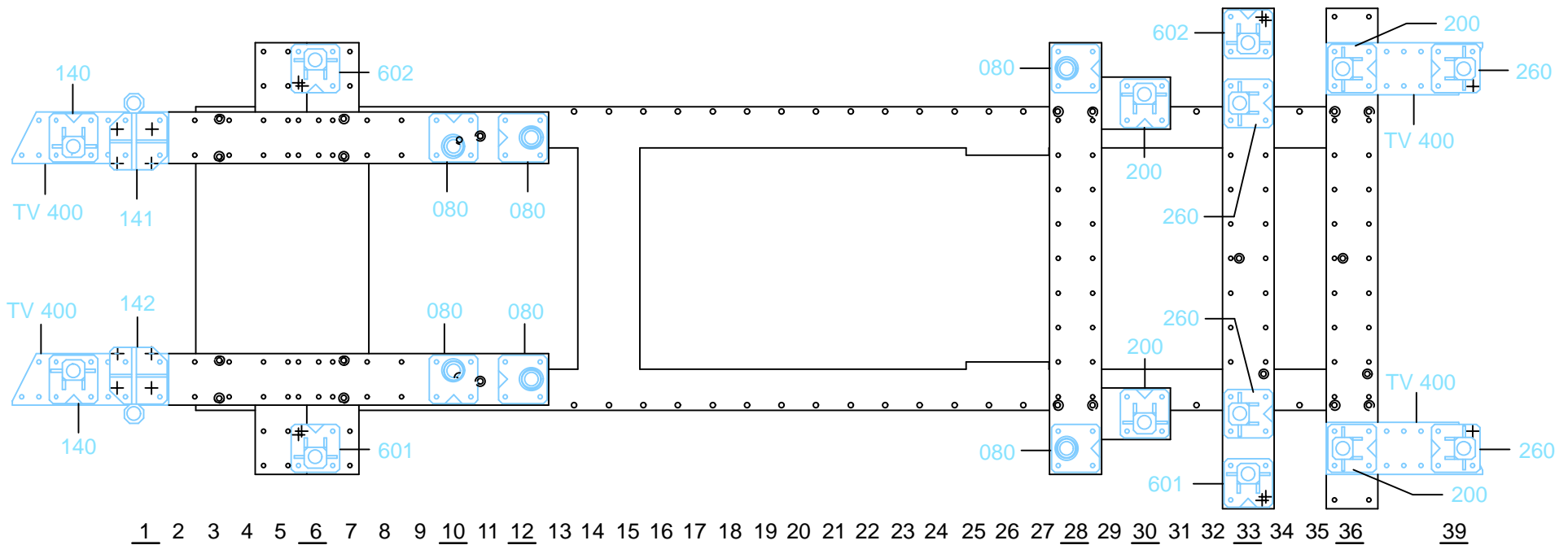

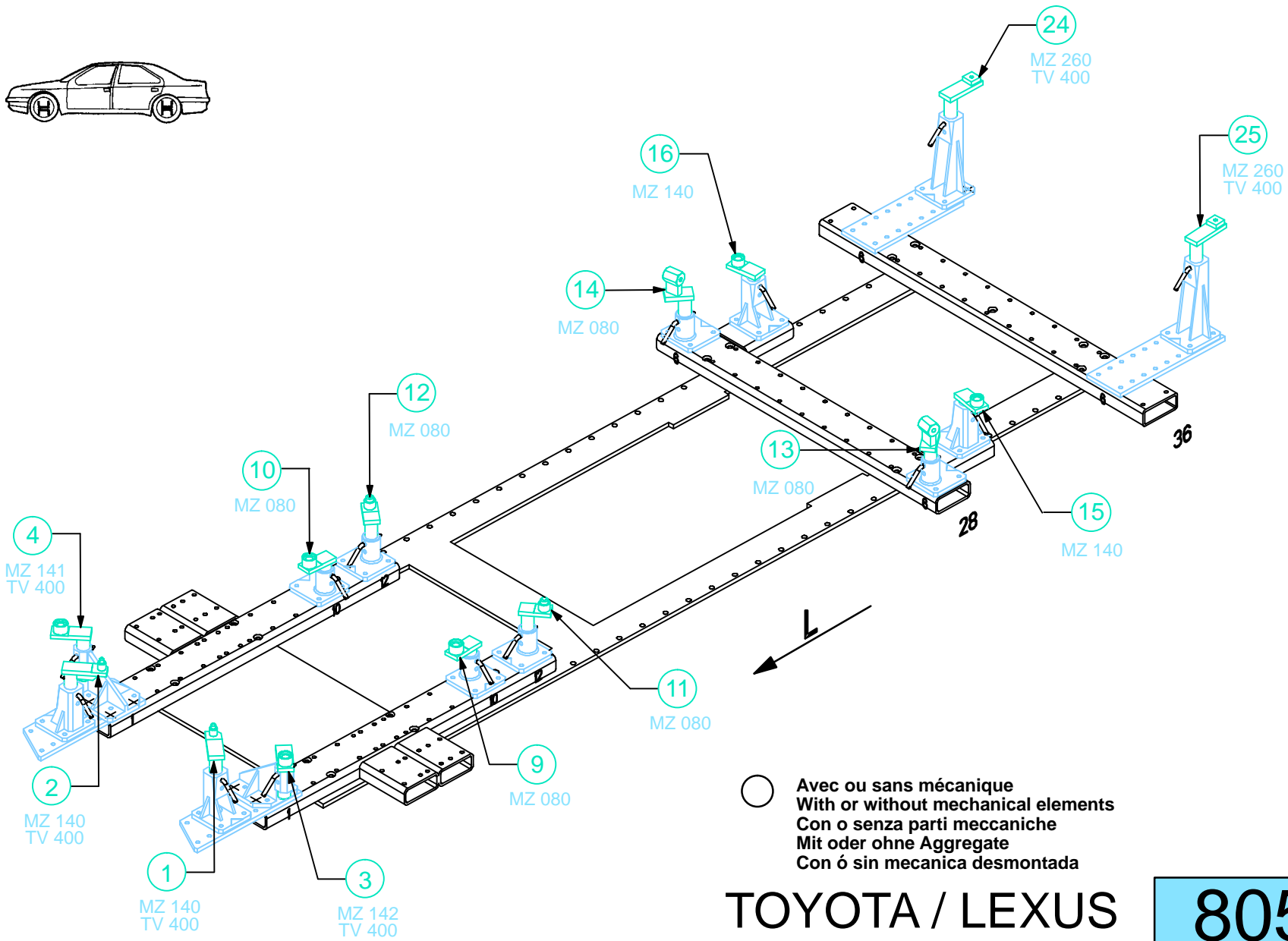
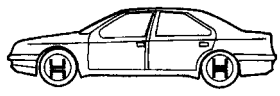

○ Avec ou sans mécanique
With or without mechanical elements
Con o senza parti meccaniche
Mit oder ohne Aggregate
Con ó sin mecanica desmontada

TOYOTA / LEXUS

805.300

58 Kg 09.09.99 434-D-60B

