

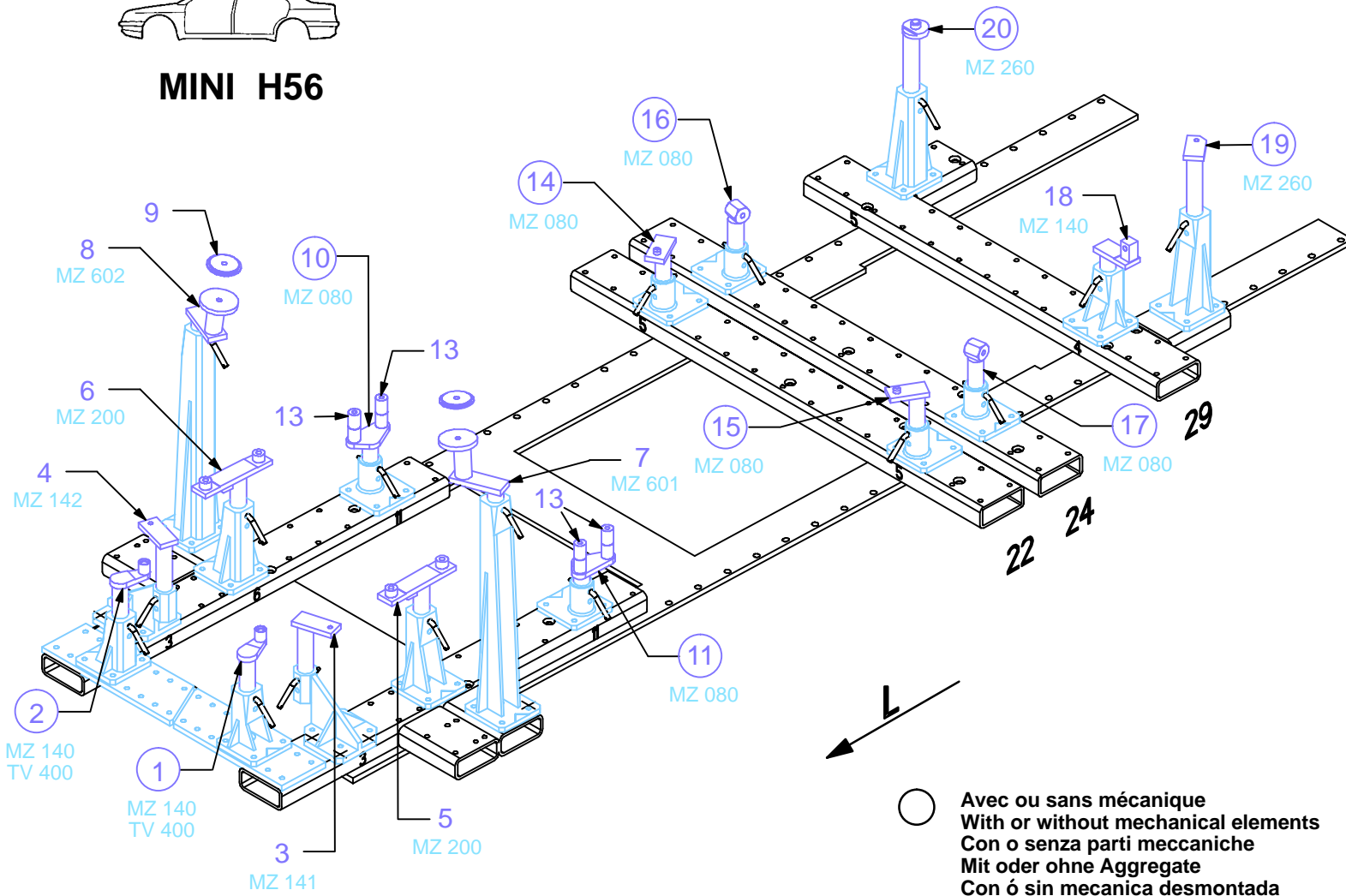

MINI H56



REP.	REFERENCE	PDS	NB	MZ
1	803.7001	2,4	1	140
2	803.7002	2,4	1	140
3	803.7003	2,5	1	141
4	803.7004	2,5	1	142
5	803.7005	3,0	1	200
6	803.7006	3,0	1	200
7	803.7007	2,8	1	601
8	803.7008	2,8	1	602
9	803.7009	0,4	2	
10	803.7010	2,1	1	080
11	803.7011	2,1	1	080
13	803.7013	0,2	4	
14	803.7014	2,1	1	080
15	803.7015	2,1	1	080
16	803.7016	1,7	1	080
17	803.7017	1,7	1	080
18	803.7018	2,0	1	140
19	803.7019	3,0	1	260
20	803.7020	2,8	1	260
21	803.7021	2,6	1	601
22	803.7022	2,6	1	602
23	803.7023	1,7	1	080
24	803.7024	1,7	1	080

M 12-30	2
M 10x1,25-35	1
M 10x1,25-45	2
M 10x1,25-70	2
M 10x1,25-110	4
M 12x1,25-90	4

○ Avec ou sans mécanique
With or without mechanical elements
Con o senza parti meccaniche
Mit oder ohne Aggregate
Con ó sin mecanica desmontada

MITSUBISHI

803.300

52 Kg 09.03.2000 421-D-25A

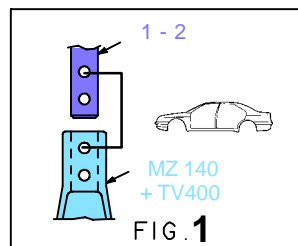
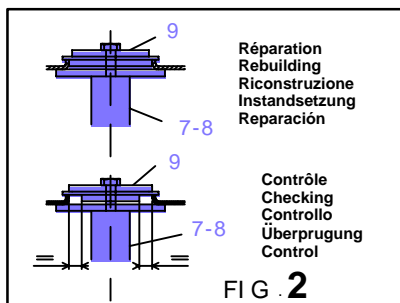
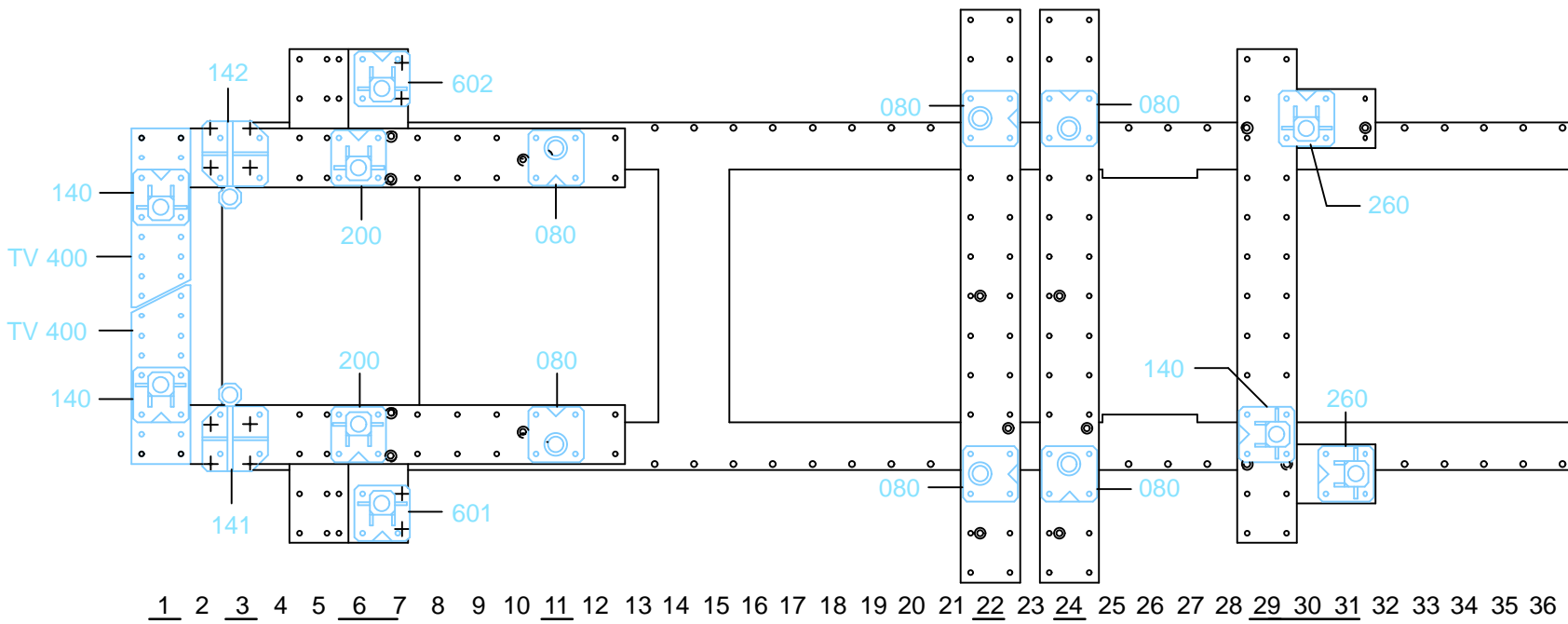



MINI H56

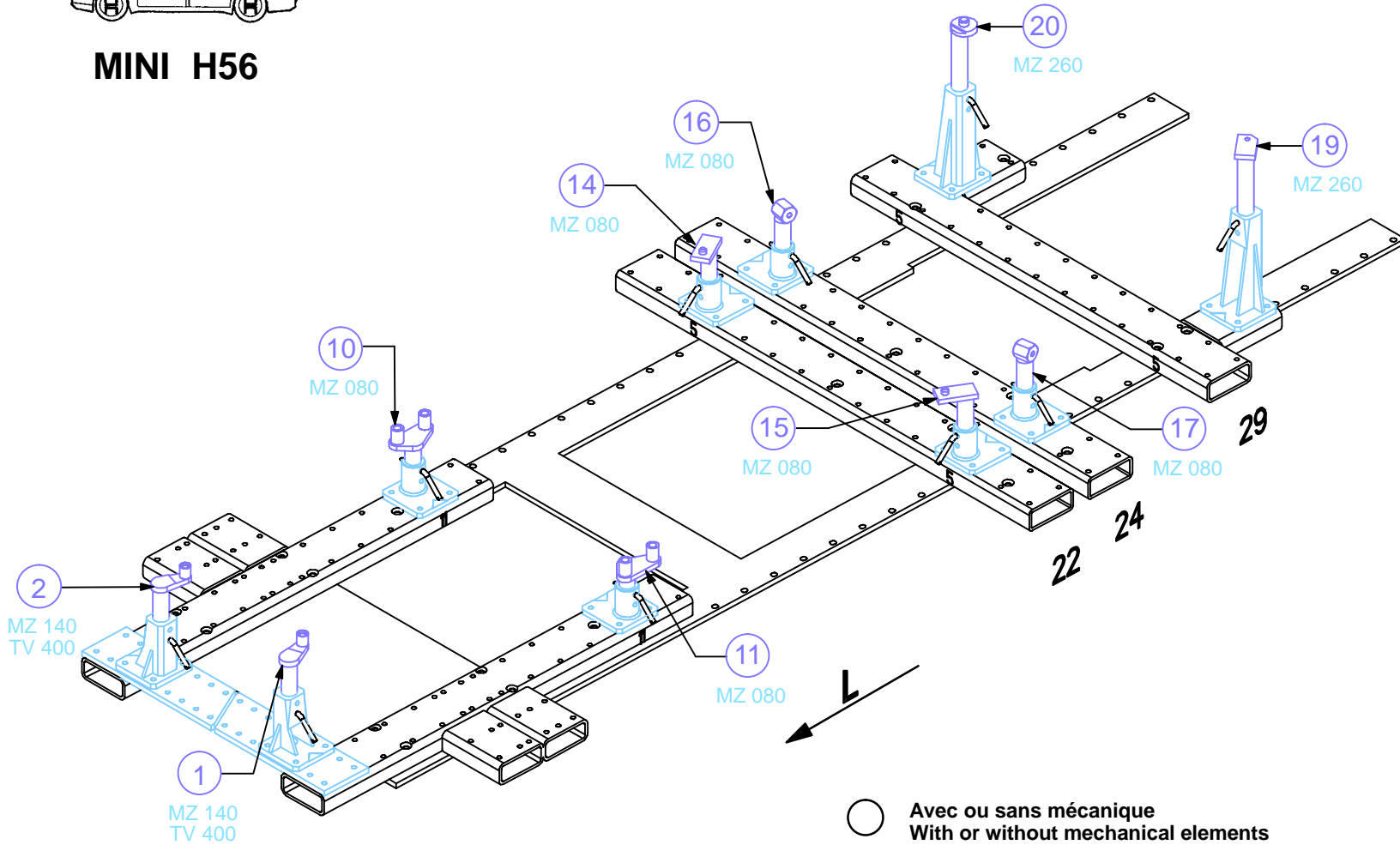

○ Avec ou sans mécanique
With or without mechanical elements
Con o senza parti meccaniche
Mit oder ohne Aggregate
Con ó sin mecanica desmontada

MITSUBISHI

803.300

52 Kg | 09.03.2000 | 421-D-25B

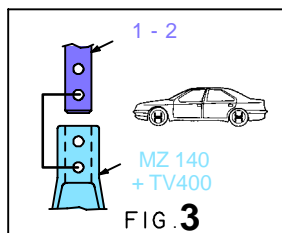
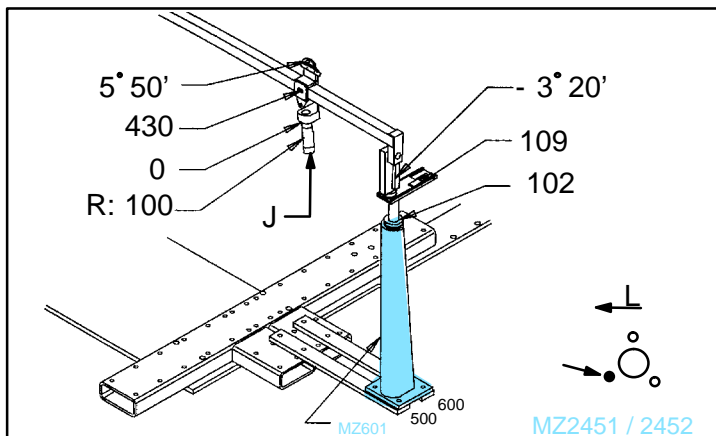
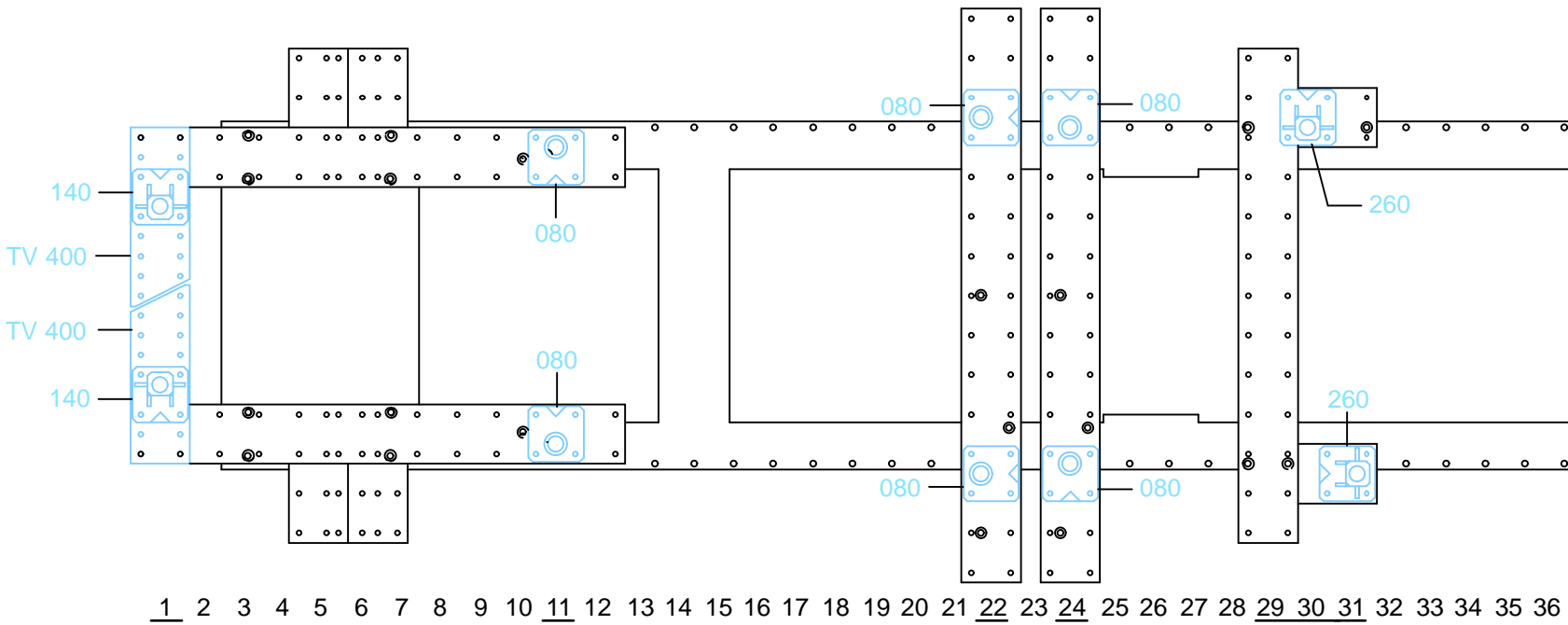



JR H57

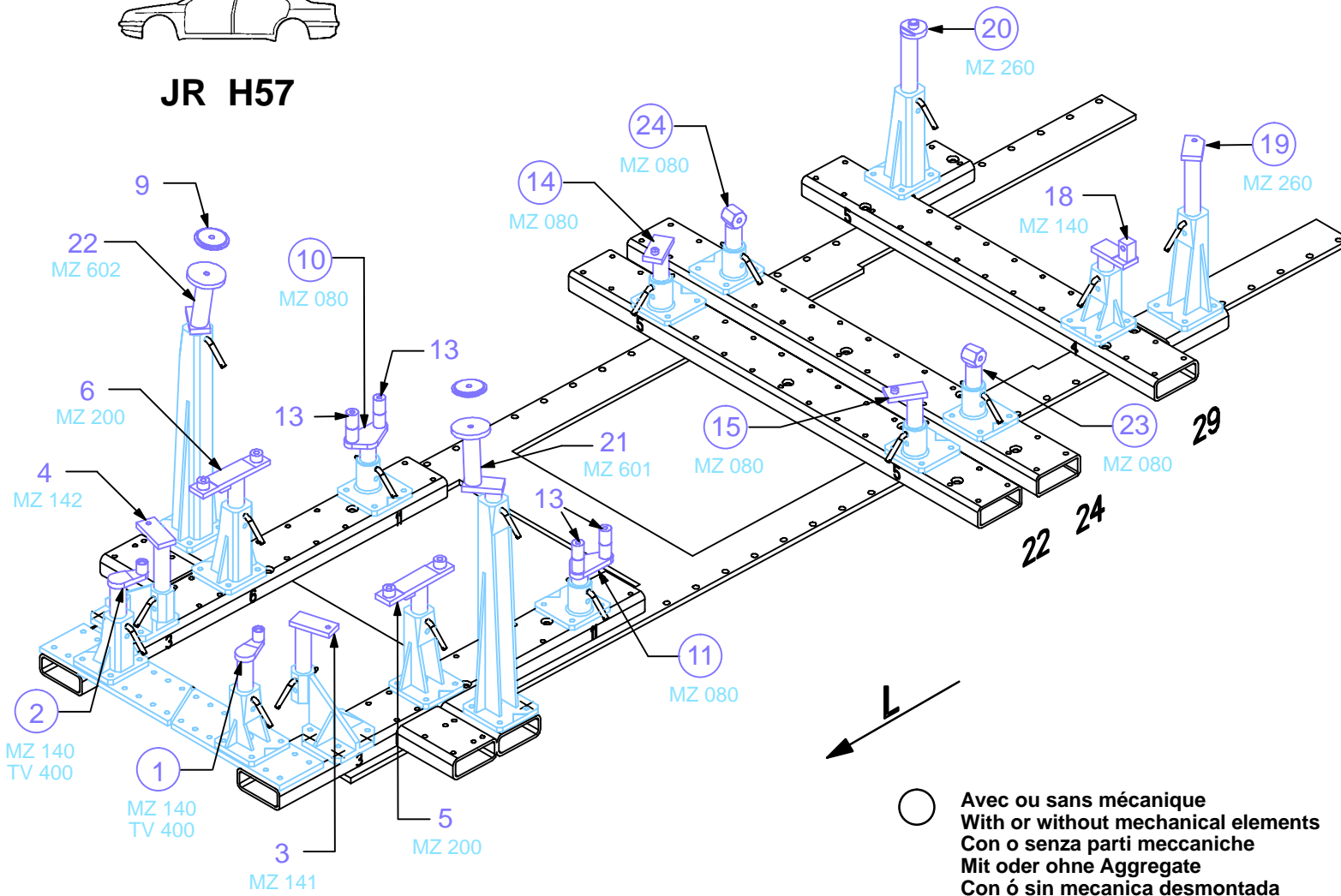

○ Avec ou sans mécanique
With or without mechanical elements
Con o senza parti meccaniche
Mit oder ohne Aggregate
Con ó sin mecanica desmontada

MITSUBISHI

803.300

52 Kg 09.03.2000 421-D-25C

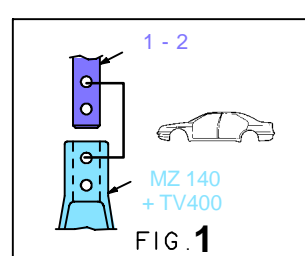
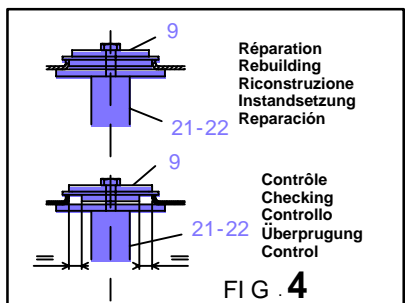
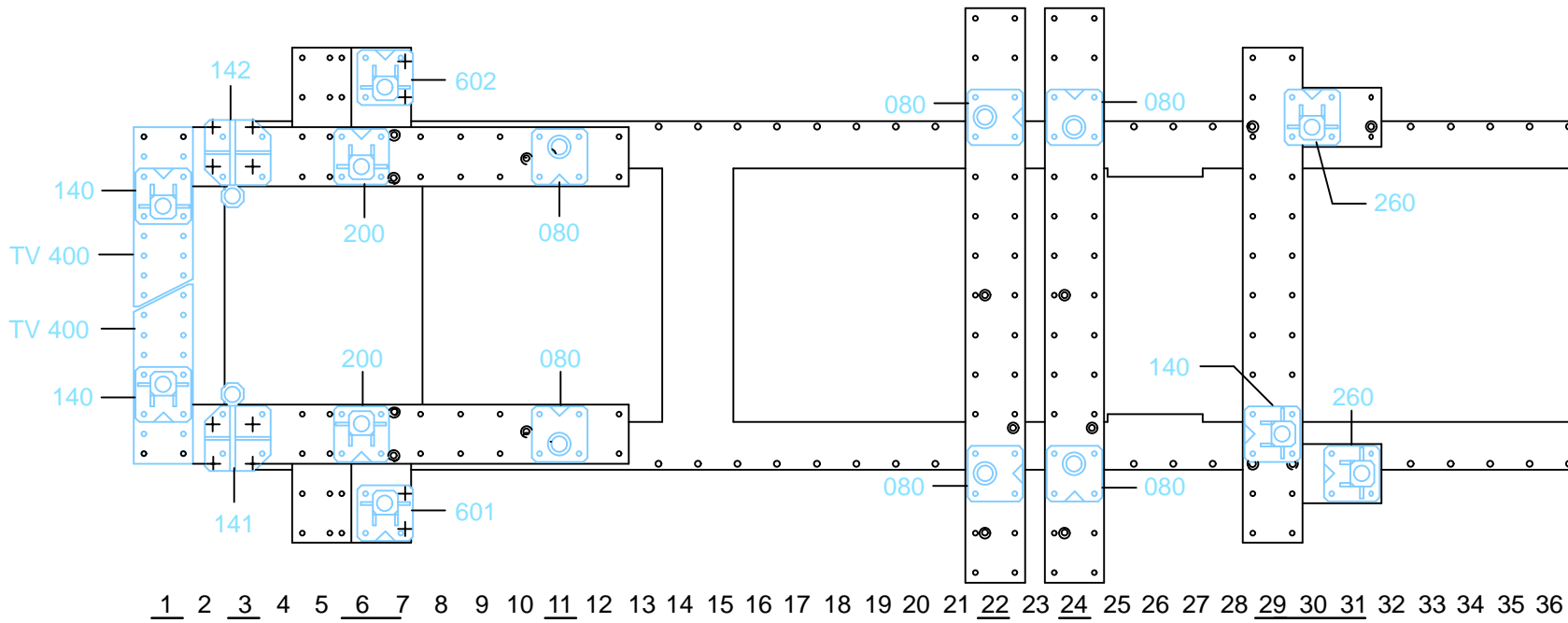

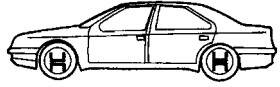

JR H57

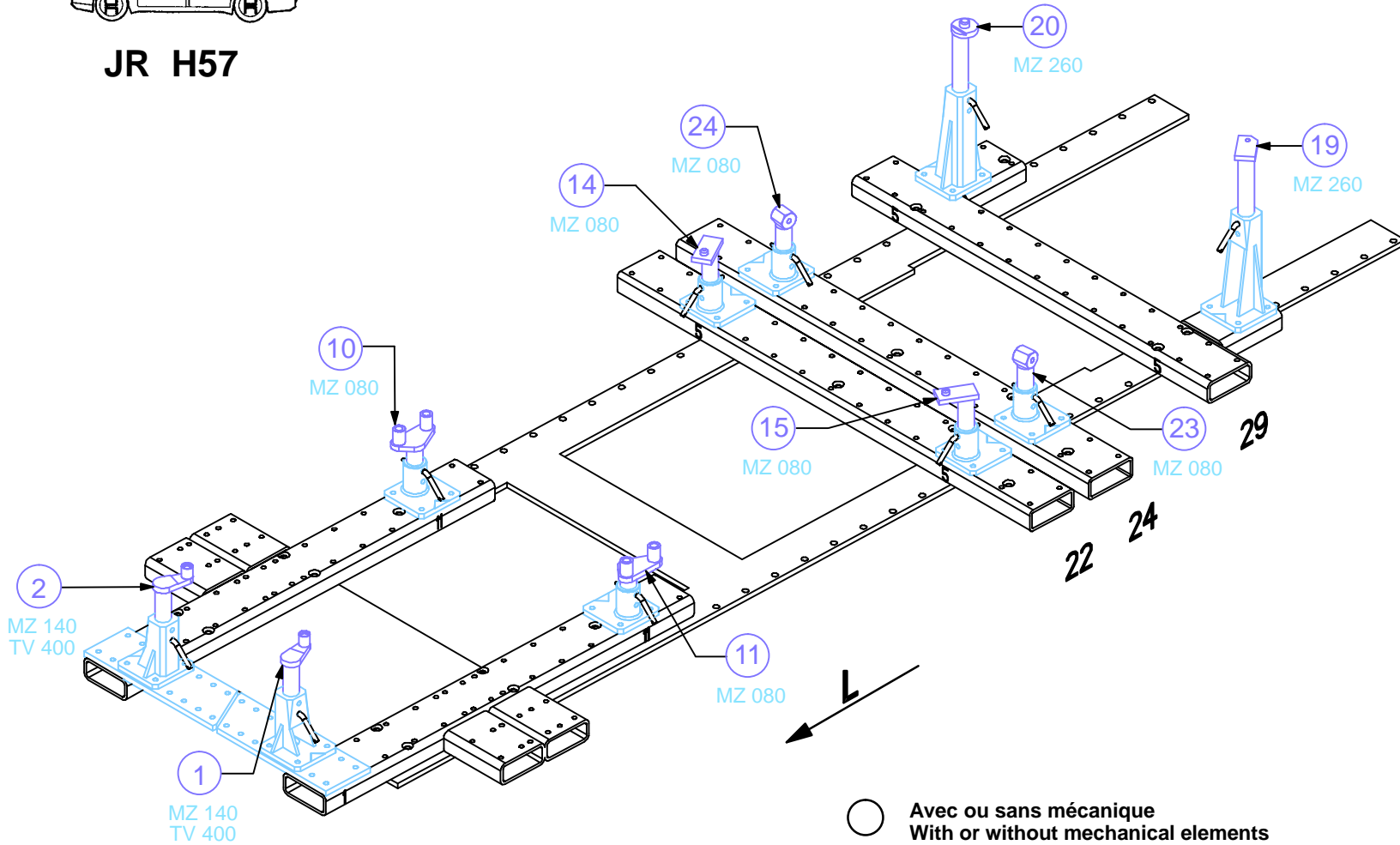

○ Avec ou sans mécanique
With or without mechanical elements
Con o senza parti meccaniche
Mit oder ohne Aggregate
Con ó sin mecanica desmontada

MITSUBISHI

803.300

52 Kg | 09.03.2000 | 421-D-25D

