

- Pour le contrôle de la partie arrière du véhicule, utiliser les dessins du 7906.300 correspondant au véhicule à contrôler en intercalant les cales repère 69 entre le marbre et les traverses.
- To check the rear end of the vehicle, use drawings 7906.300 corresponding to the vehicle, while inserting plates 69 between the bench and the crossmembers.
- Zur Kontrolle des Heckteils sind die Zeichnungen 7906.300 zu verwenden, und Keile 69 zwischen der Richtbank und den Traversen einzufügen.
- Per il controllo della parte anteriore del veicolo, utilizzare i disegni 7906.300, ed inserire placche 69 tra il banco e le traverse.
- Para el control de la parte trasera del vehículo, utilizar los dibujos del 7906.300 que corresponden al vehículo que hay que controlar intercalando las calas referencia 69 entre el banco y las traviesas.

**MARBRE SVN XL UNIQUEMENT
BENCH SVN XL ONLY
NUR RICHTBANK SVN XL
SOLO BANCO SVN XL
BANCO SVN XL UNICAMENTE**

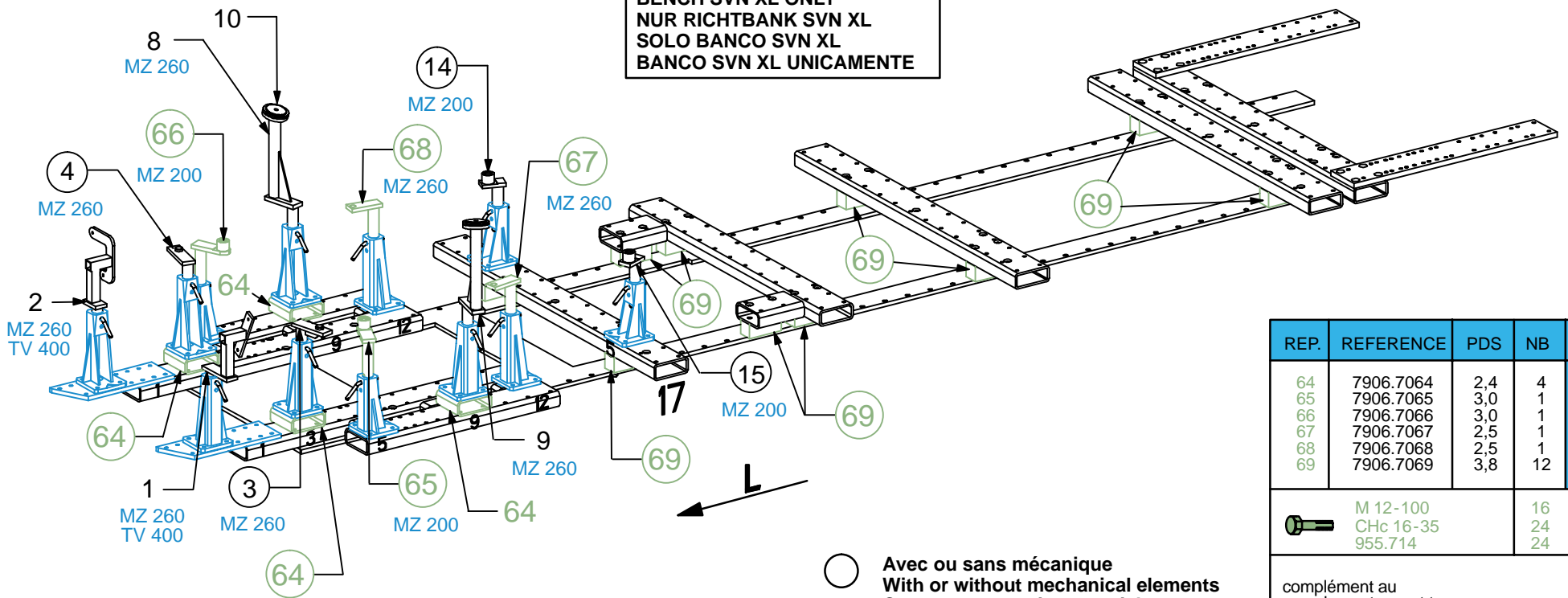

○ Avec ou sans mécanique
With or without mechanical elements
Con o senza parti meccaniche
Mit oder ohne Aggregate
Con ó sin mecanica desmontada

REP.	REFERENCE	PDS	NB	MZ
64	7906.7064	2,4	4	
65	7906.7065	3,0	1	200/140
66	7906.7066	3,0	1	200/140
67	7906.7067	2,5	1	260/140
68	7906.7068	2,5	1	260/140
69	7906.7069	3,8	12	

M 12-100	16
CHc 16-35	24
955.714	24

complément au
complementary set to
complemento al
zusatz zu

7906.300

MERCEDES BENZ

7906.309

71 Kg 22.05.2008 420-D-36A1

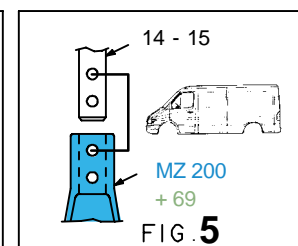
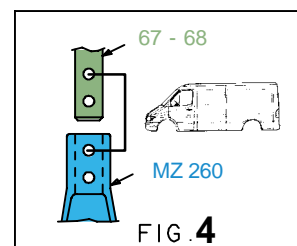
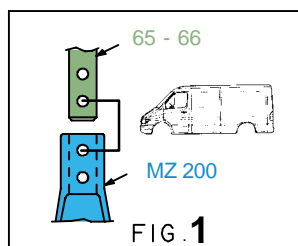
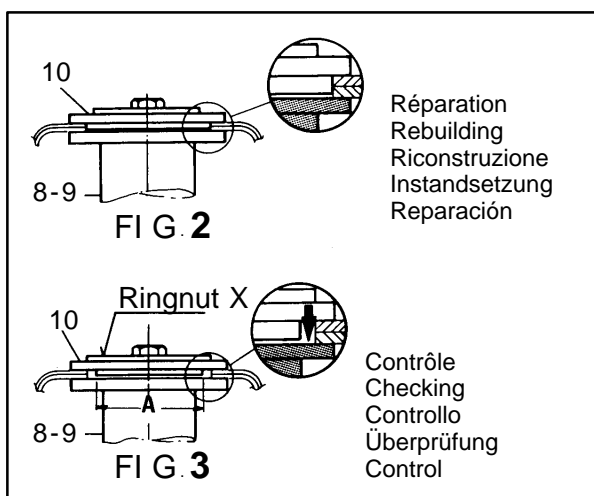
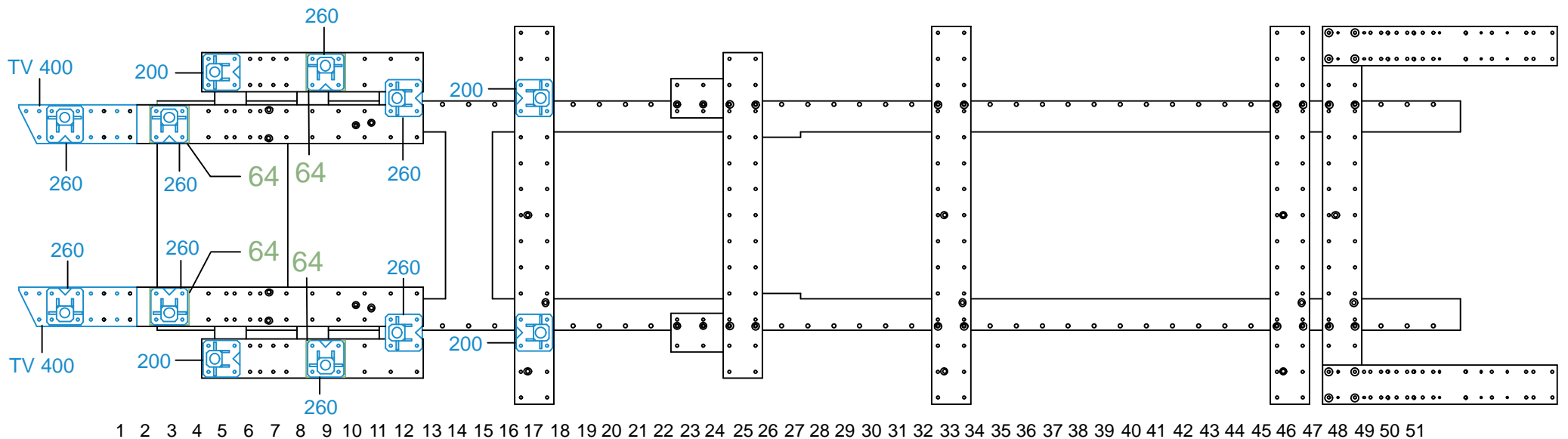

7906.309-RVA3-1 00

MARBRE SVN XL UNIQUEMENT
BENCH SVN XL ONLY
NUR RICHTBANK SVN XL
SOLO BANCO SVN XL
BANCO SVN XL UNICAMENTE

- Pour le controle de la partie arriere du véhicule, utiliser les dessins du 7906.300 correspondant au véhicule à contrôler en intercalant les cales repère 69 entre le marbre et les traverses.
- To check the rear end of the vehicle, use drawings 7906.300 corresponding to the vehicle, while inserting plates 69 between the bench and the crossmembers.
- Zur Kontrolle des Heckteils sind die Zeichnungen 7906.300 zu verwenden, und Keile 69 zwischen der Richtbank und den Traversen einzufügen.
- Per il controllo della parte anteriore del veicolo, utilizzare i disegni 7906.300, ed inserire placche 69 tra il banco e le traverse.
- Para el control de la parte trasera del vehículo, utilizar los dibujos del 7906.300 que corresponden al vehículo que hay que controlar intercalando las calas referencia 69 entre el banco y las traviesas.

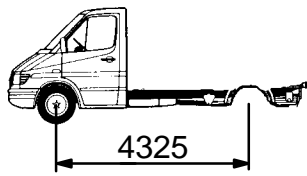
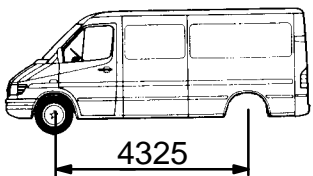
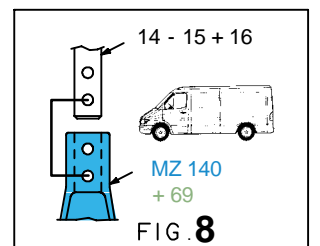
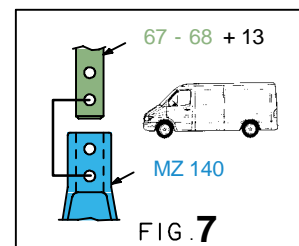
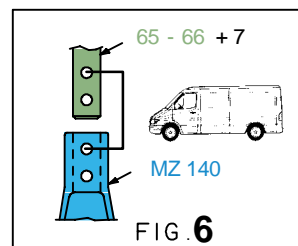
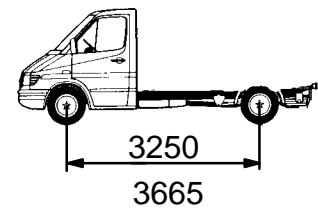
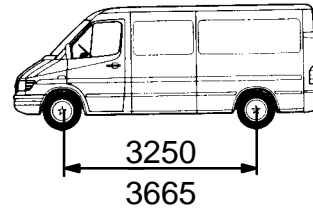
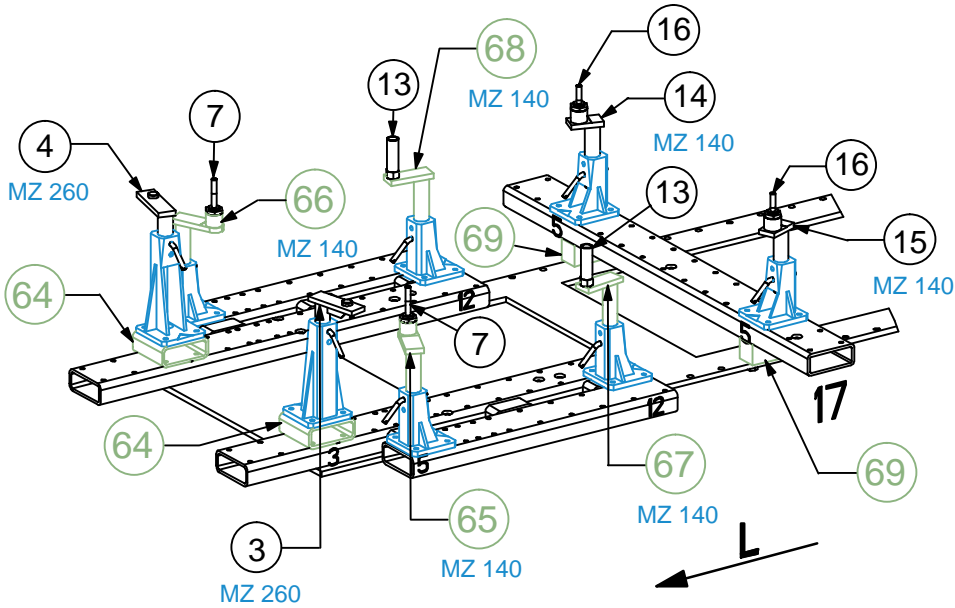

- Avec ou sans mécanique
- With or without mechanical elements
- Con o senza parti meccaniche
- Mit oder ohne Aggregate
- Con ó sin mecánica desmontada

MERCEDES BENZ

7906.309

71 Kg | 22.05.2008 | 420-D-36B1

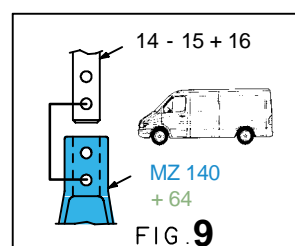
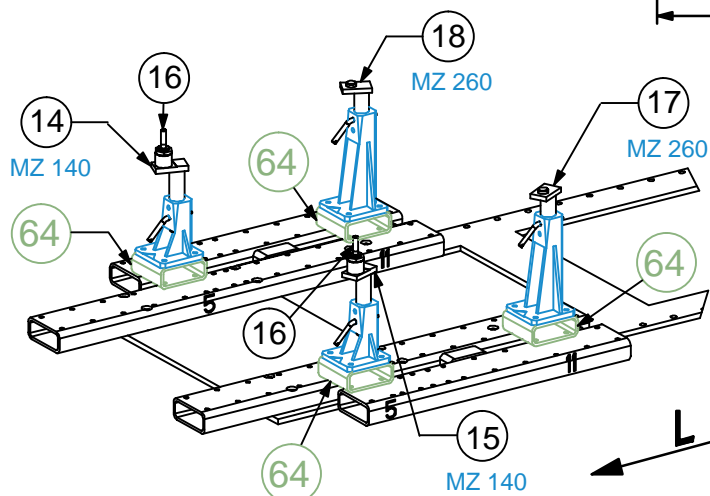
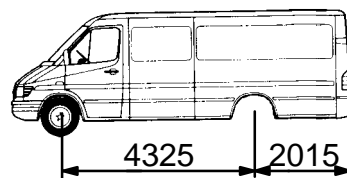
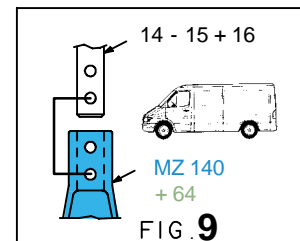
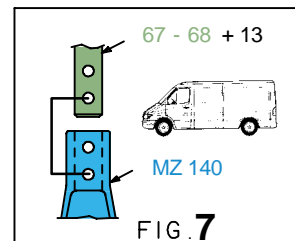
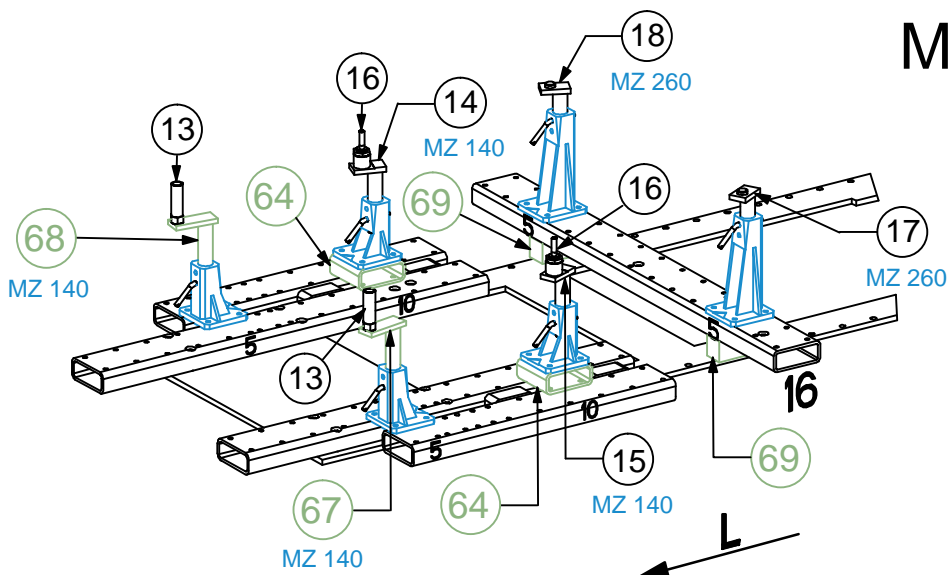

7906.309-RVA3-1 | 00