

Choc avant
Front crash
Frontreparatur
Urto anteriore
Choque delantero

Tous types
All types
Alle typen
Tutti tipi
Todos tipos

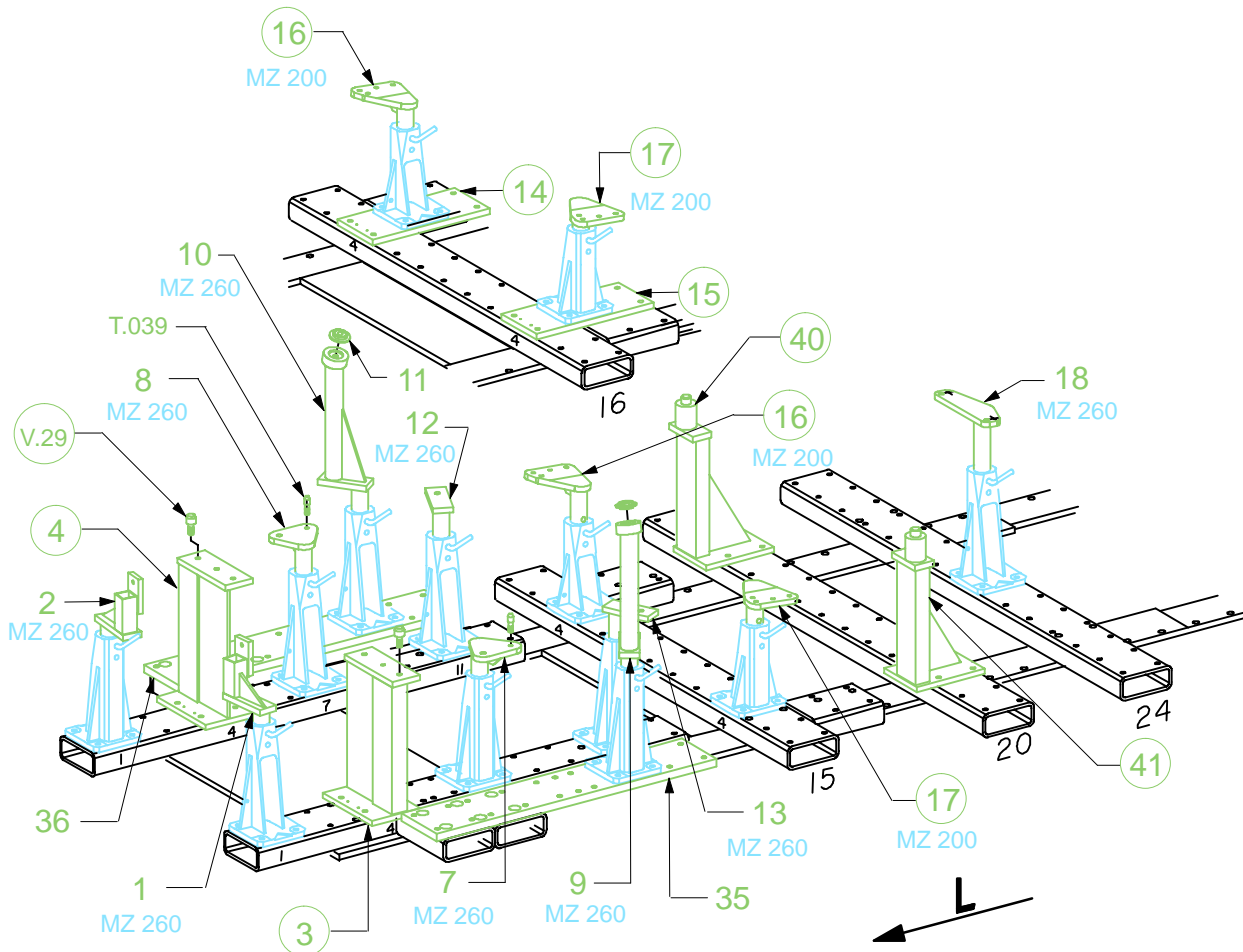

○ Avec ou sans mécanique
With or without mechanical elements
Con o senza parti meccaniche
Mit oder ohne Aggregate
Con ó sin mecanica desmontada

VAS 5003

755.300

253 Kg 12.12.96 438-D-15A1

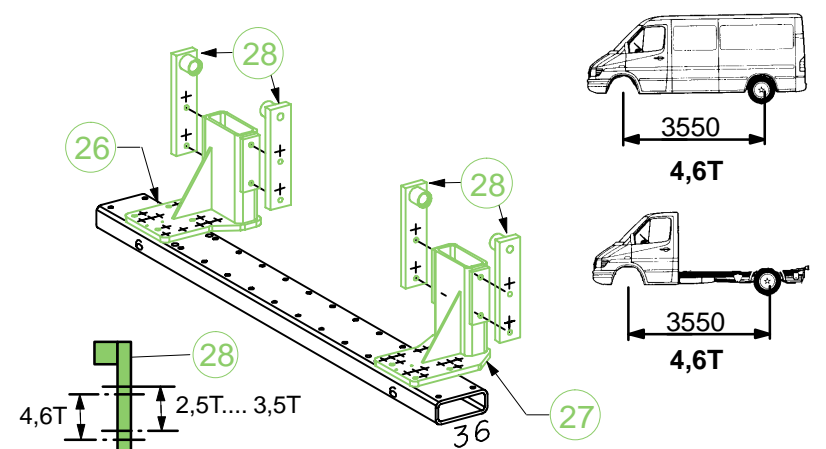
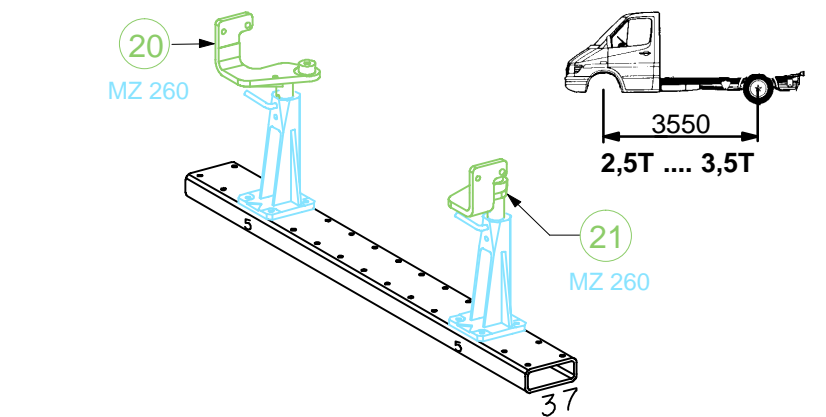
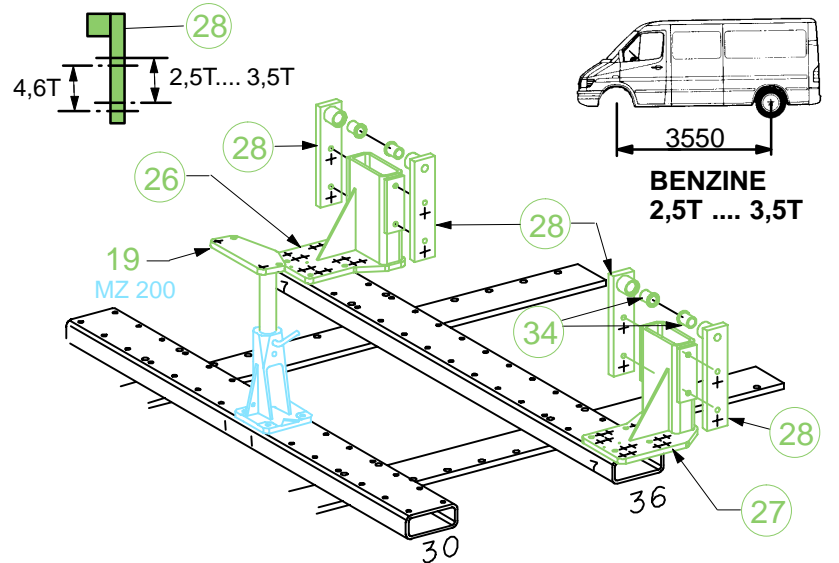
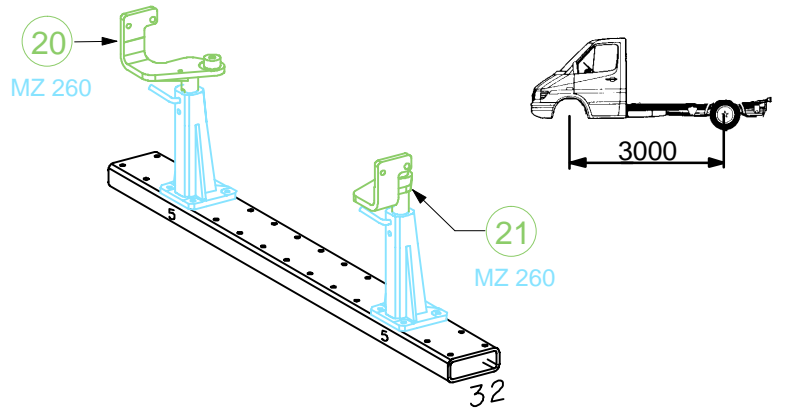
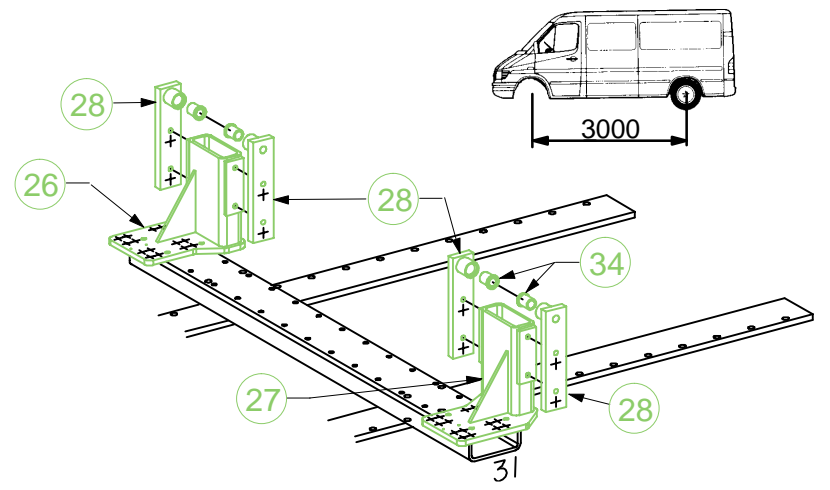

Choc avant
Front crash
Frontreparatur
Urto anteriore
Choque delantero

Tous types
All types
Alle typen
Tutti tipi
Todos tipos

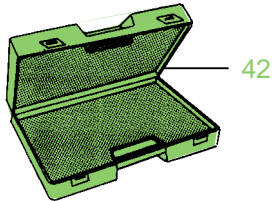
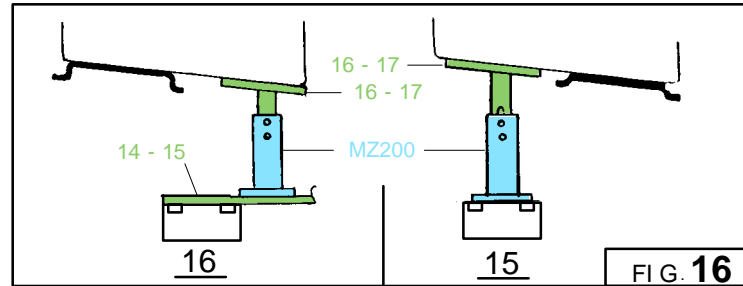
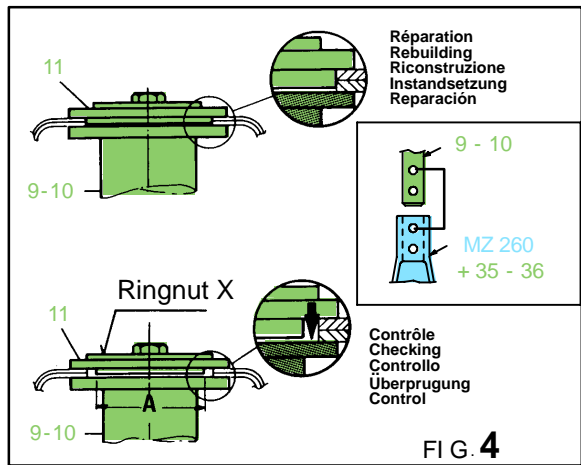
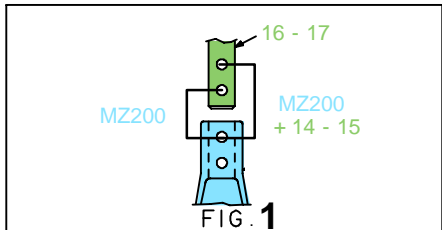
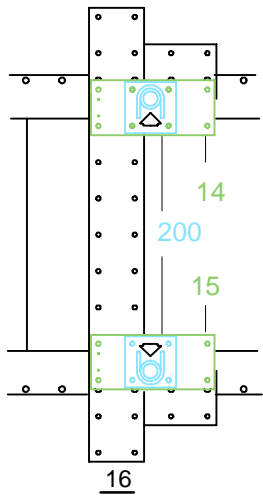
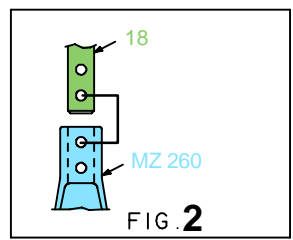
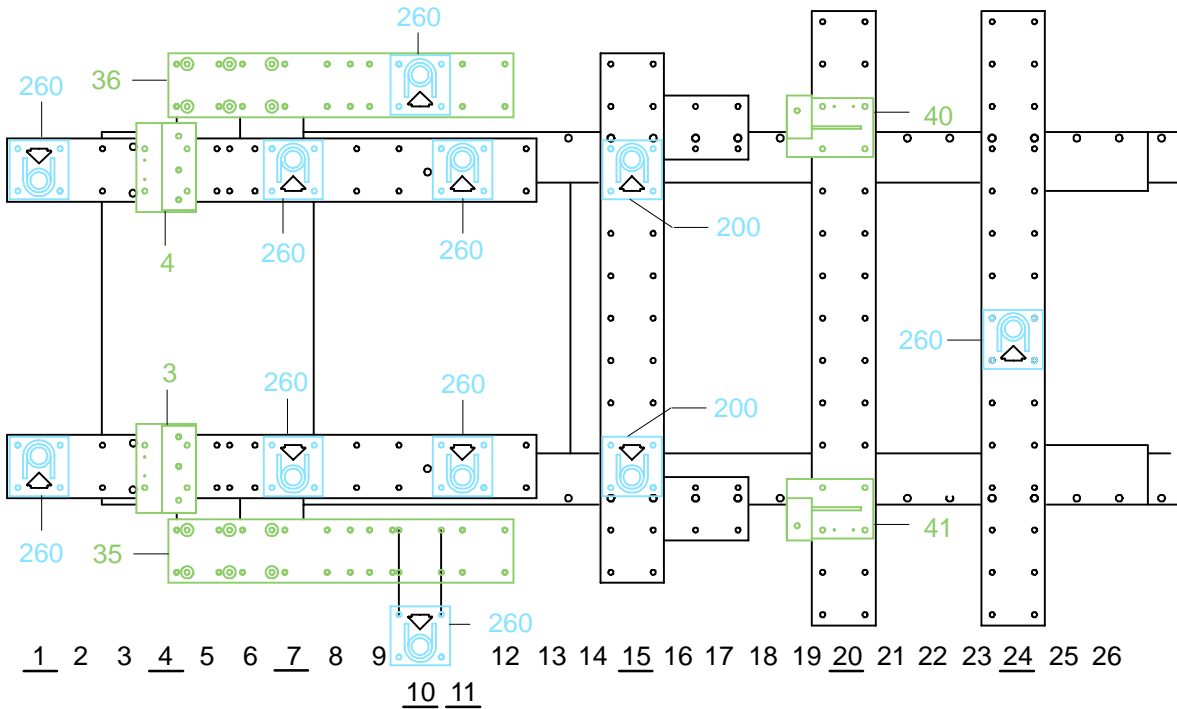

REP.	REFERENCE	PDS	NB	MZ
1	7001.7001	2,6	1	260
2	7001.7002	2,6	1	260
3	7001.7003	11,1	1	
4	7001.7004	11,1	1	
7	7001.7007	2,5	1	260
8	7001.7008	2,5	1	260
9	7001.7009	3,7	1	260
10	7001.7010	3,7	1	260
11	7001.7011	0,1	2	
12	7001.7012	2,0	1	260
13	7001.7013	2,0	1	260
14	7001.7014	5,8	1	
15	7001.7015	5,8	1	
16	7001.7016	3,1	1	200
17	7001.7017	3,1	1	200
18	7001.7018	3,8	1	260
19	7001.7019	4,8	1	200
20	7001.7020	4,5	1	260
21	7001.7021	4,5	1	260
22	7001.7022	0,6	2	
23	7001.7023	0,5	2	
24	7001.7024	4,9	1	
25	7001.7025	4,9	1	
26	7001.7026	12,0	1	
27	7001.7027	12,0	1	
28	7001.7028	2,5	4	
29	7001.7029	3,9	1	260
30	7001.7030	3,9	1	260
31	7001.7031	7,1	1	141/142
32	7001.7032	7,1	1	141/142
33	7001.7033	0,2	2	
34	7001.7034	0,1	4	
35	7001.7035	18,7	1	
36	7001.7036	18,7	1	
37	7001.7037	2,1	2	260
38	7001.7038	2,4	1	
39	7001.7039	2,4	1	
40	755.7040	7,5	1	
41	755.7041	7,5	1	
42	7001.7042	1,5	1	
	T.039	0,1	2	
	V.29	0,2	2	
	MZ.260	7,2	5	

M 8x25	2
M 10x30	6
M 12x25	12
M 12x30	24
M 12x35	8
M 12x45	4
M 12x60	8
M 12x90	8
M 12.150x130	4
M 14x110	2
M 14.150x110	2
M 10	8
M 12	10
M 14	2
TFHc 12x45	16

755.300

253 Kg 23.01.97 438-D-15B1

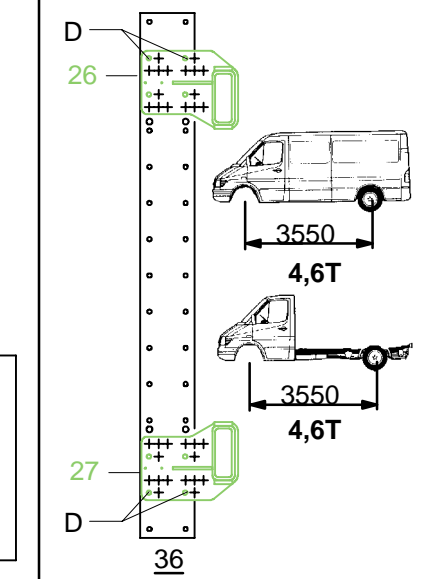
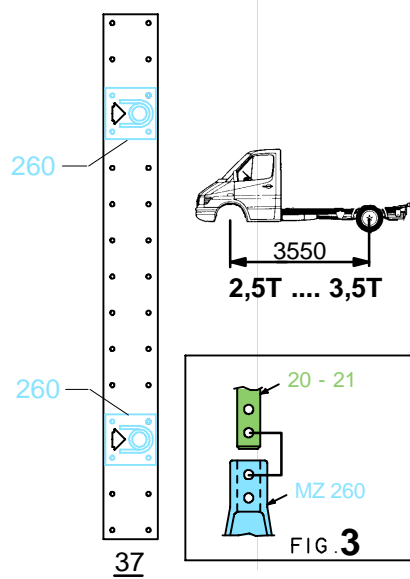
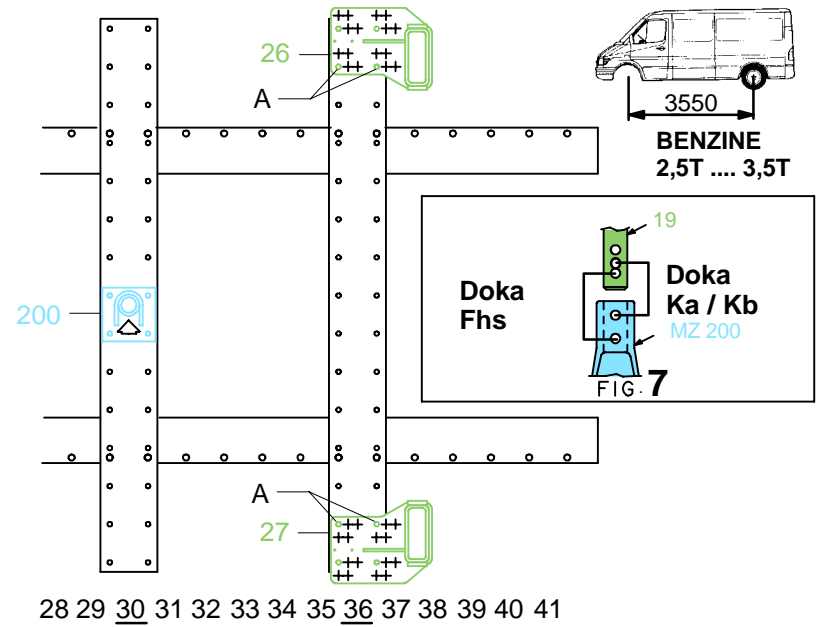
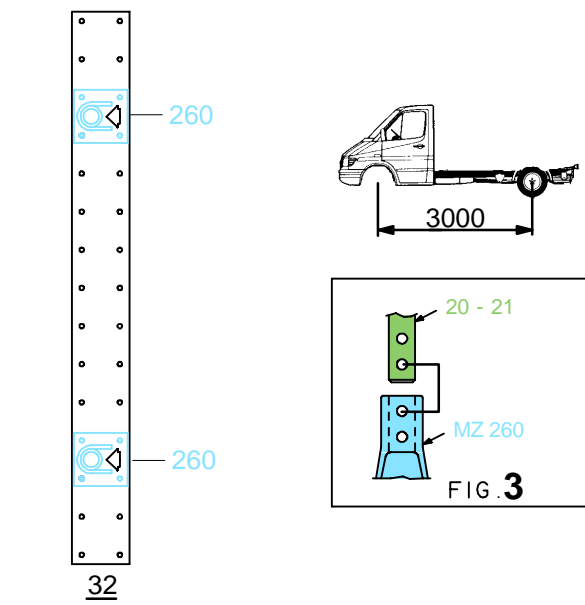
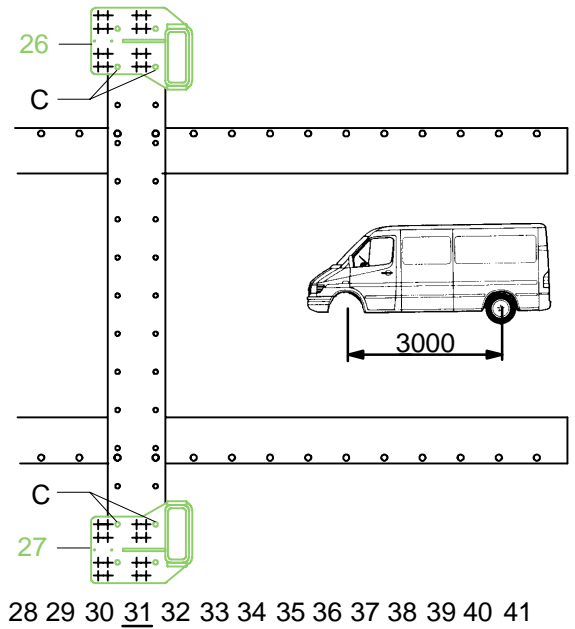

VAS 5003

Choc avant
Front crash
Frontreparatur
Urto anteriore
Choque delantero

Tous types
All types
Alle typen
Tutti tipi
Todos tipos

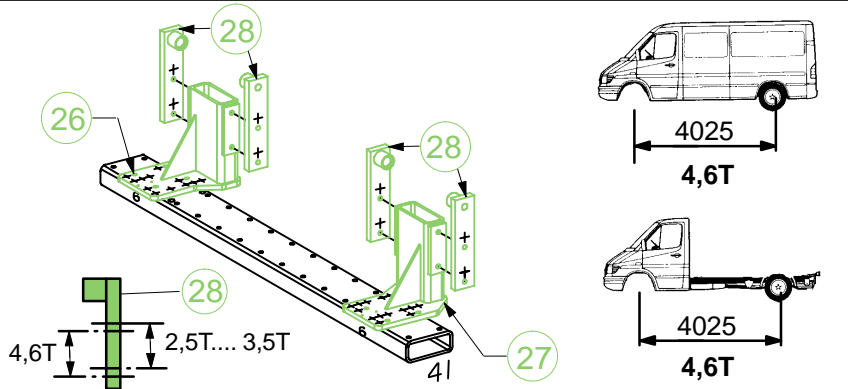
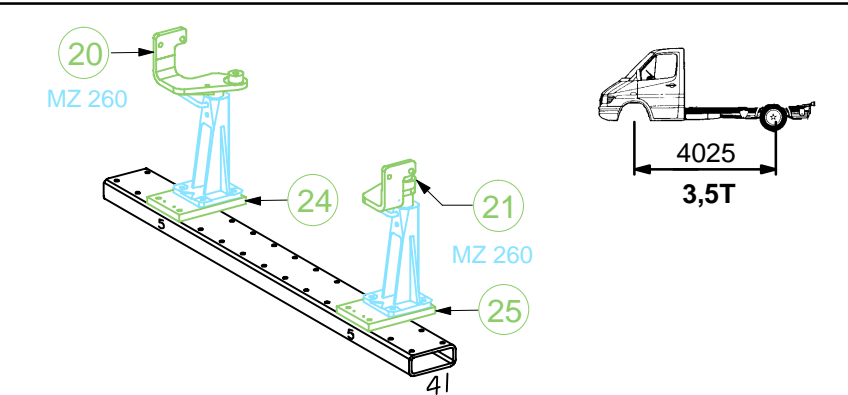
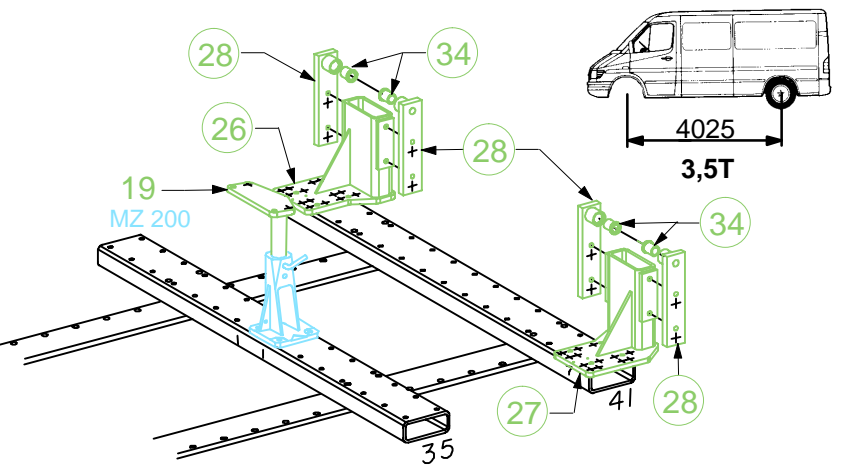
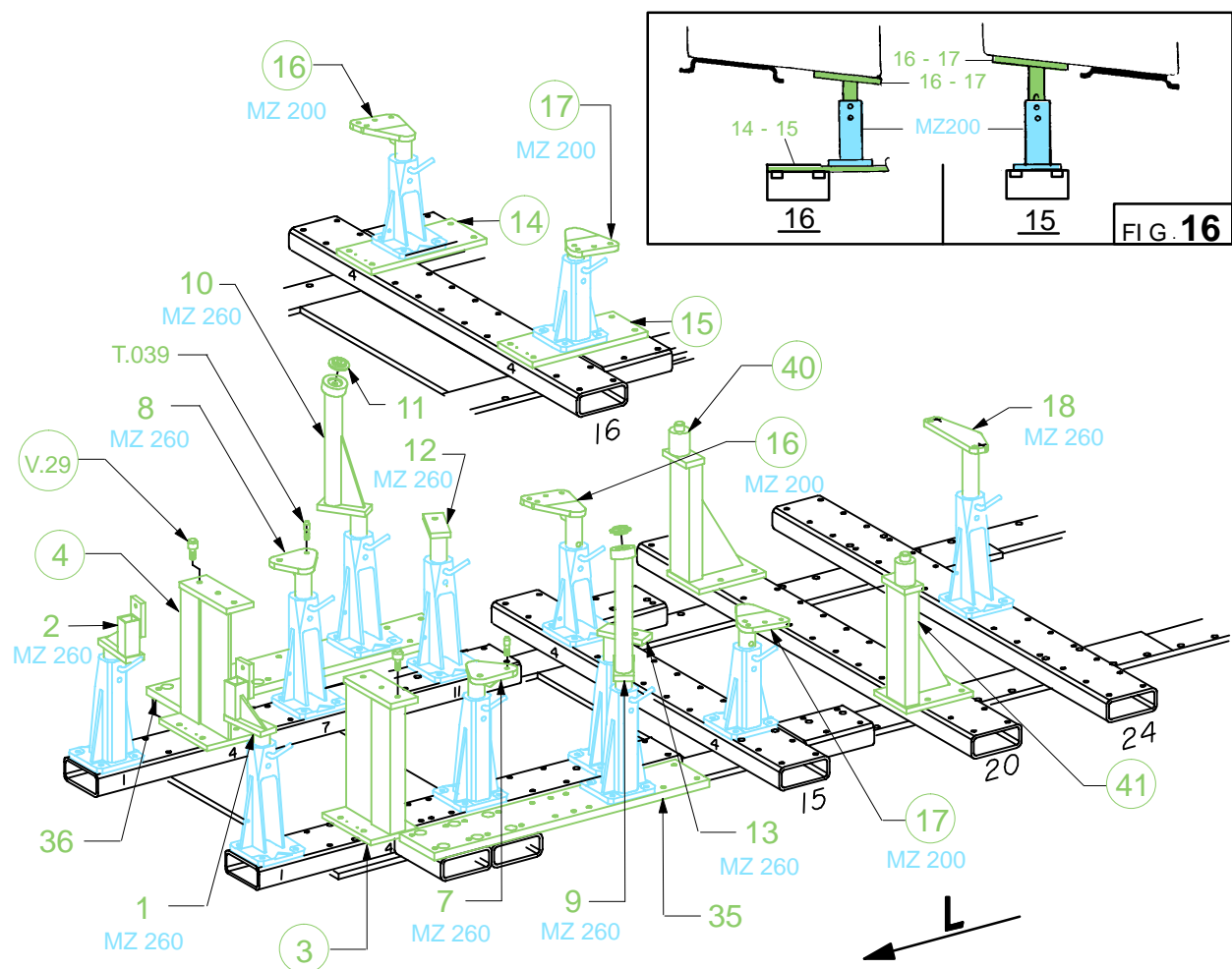
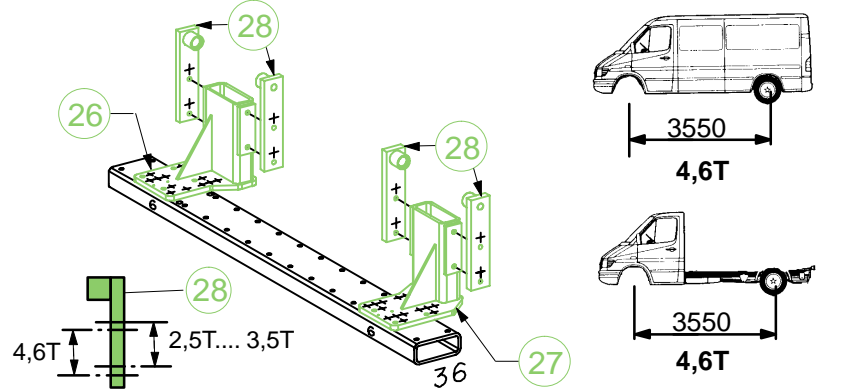
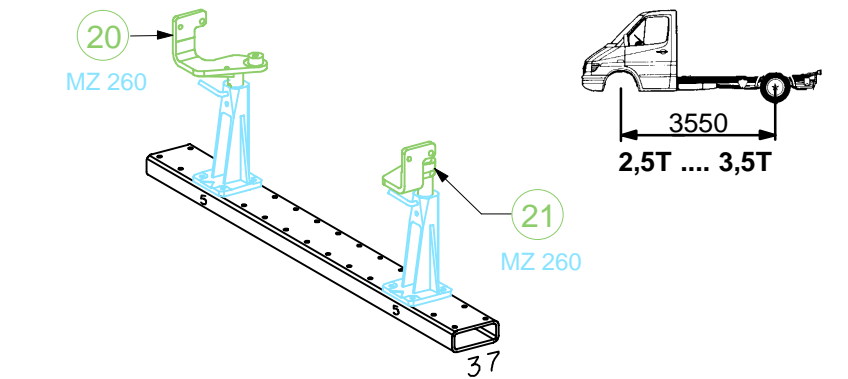
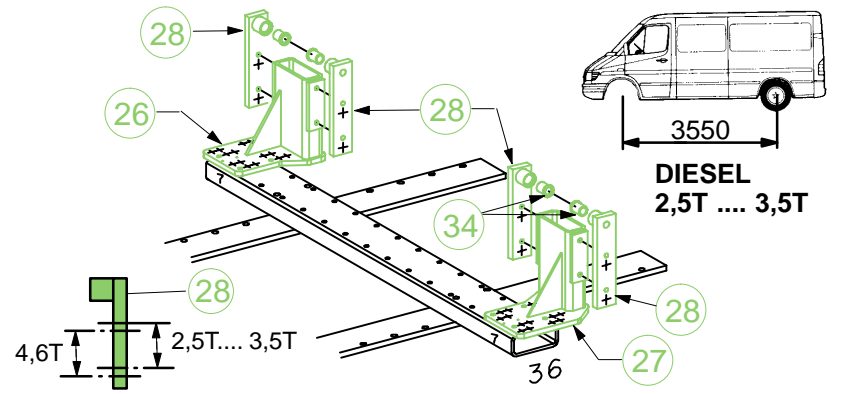
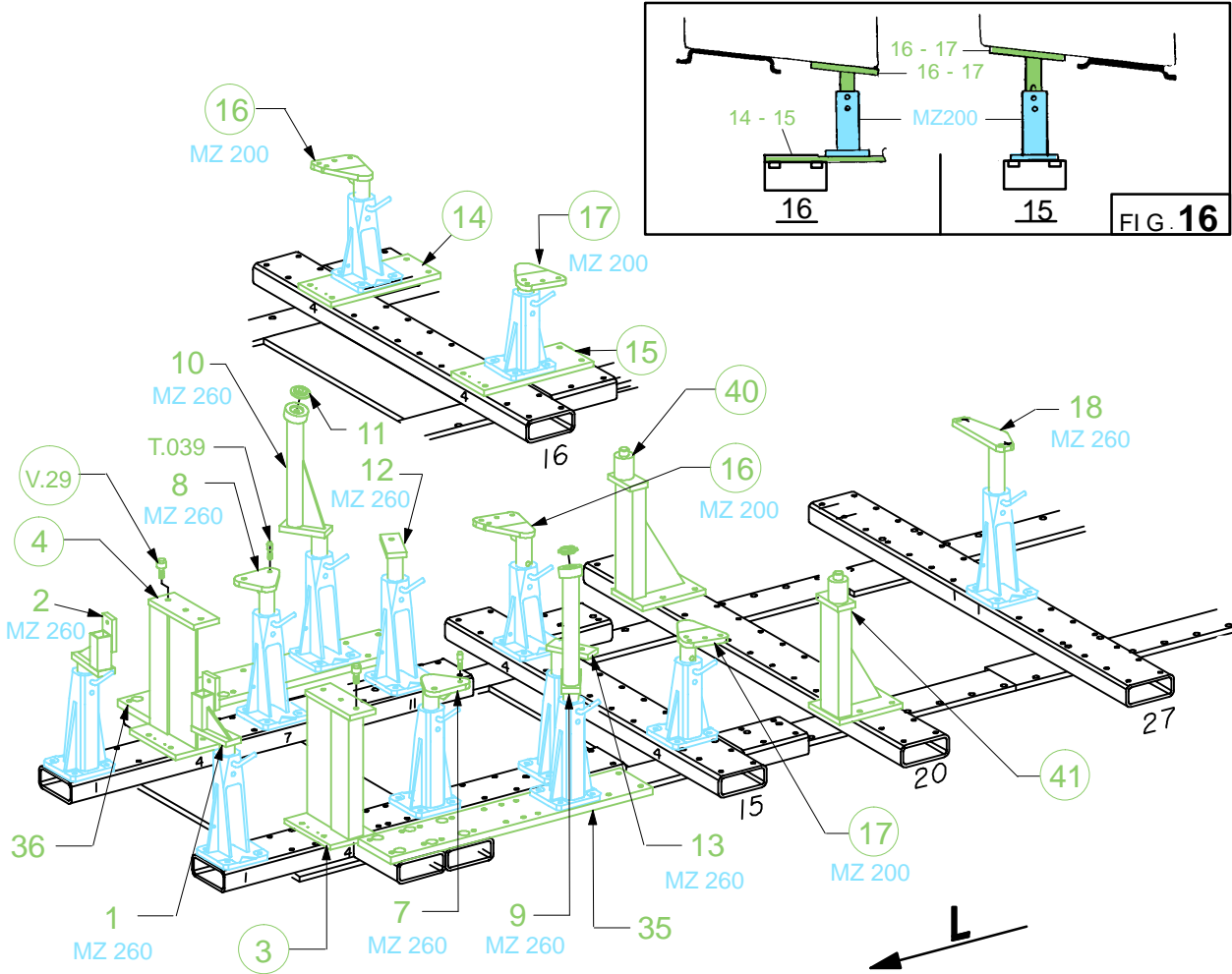

○ Avec ou sans mécanique
With or without mechanical elements
Con o senza parti meccaniche
Mit oder ohne Aggregate
Con ó sin mecánica desmontada

VAS 5003

755.300

253 Kg | 23.01.97 | 438-D-15C1

Choc avant
Front crash
Frontreparatur
Urto anteriore
Choque delantero

Tous types
All types
Alle typen
Tutti tipi
Todos tipos

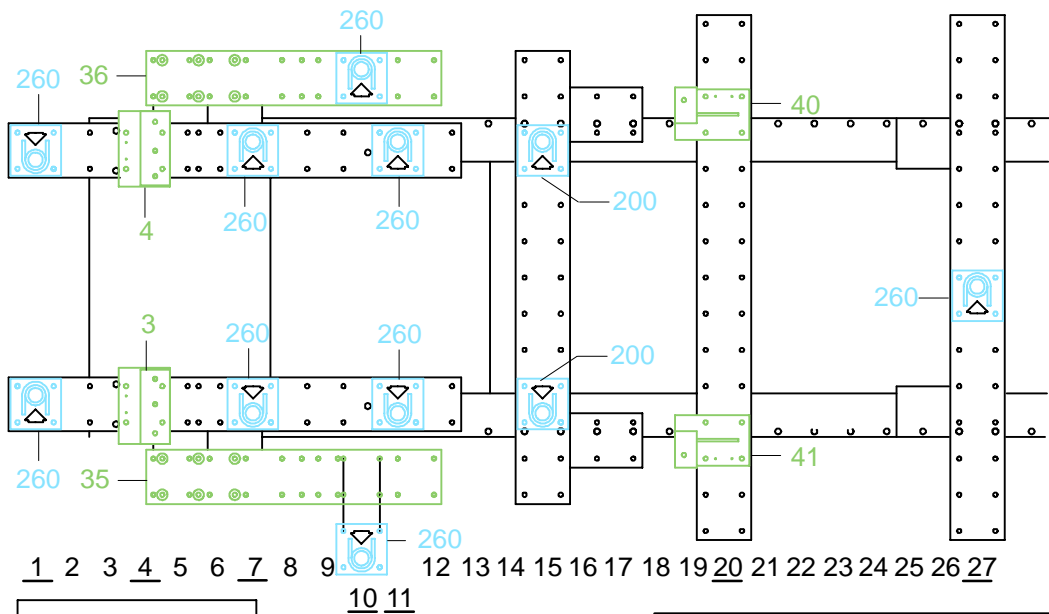

1 2 3 4 5 6 7 8 9 10 11 12 13 14 15 16 17 18 19 20 21 22 23 24 25 26 27

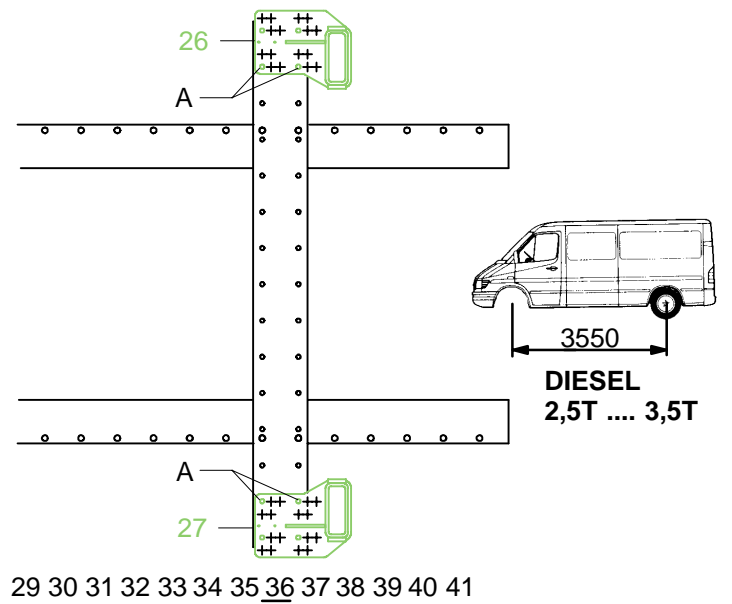
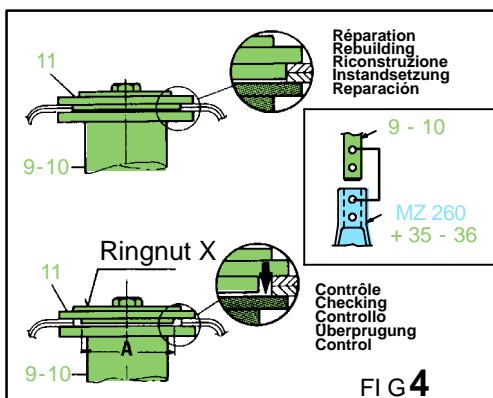
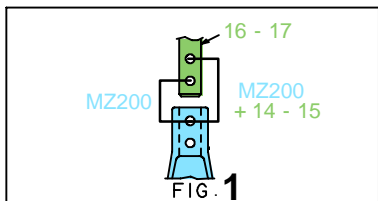
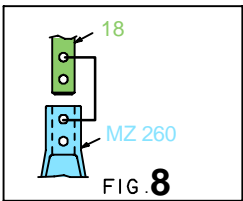

29 30 31 32 33 34 35 36 37 38 39 40 41

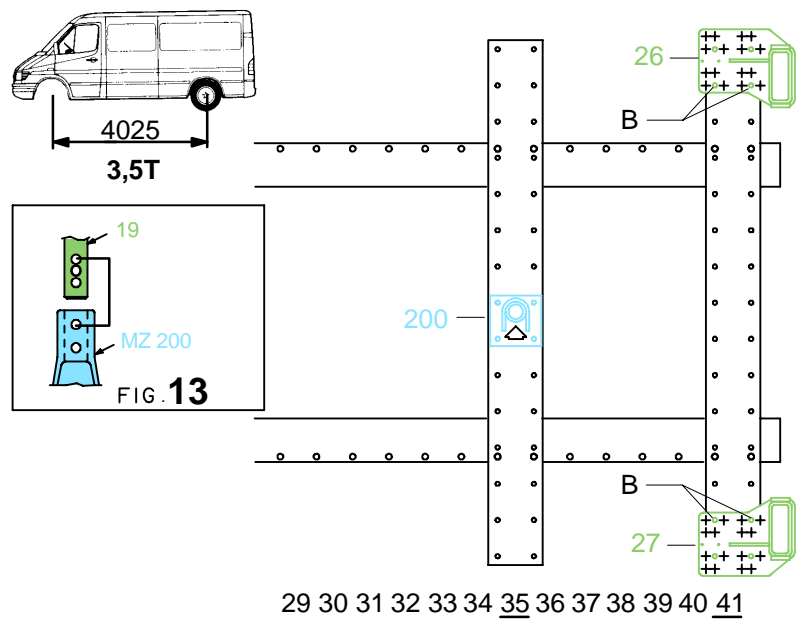
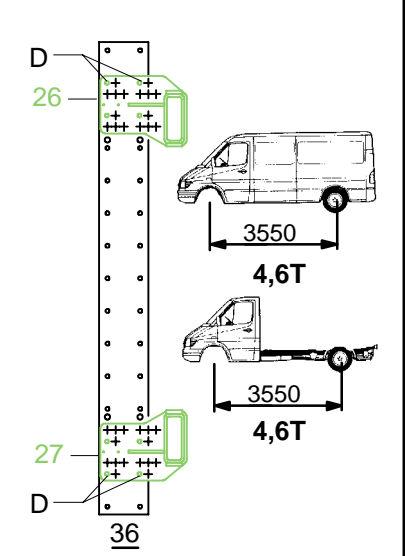
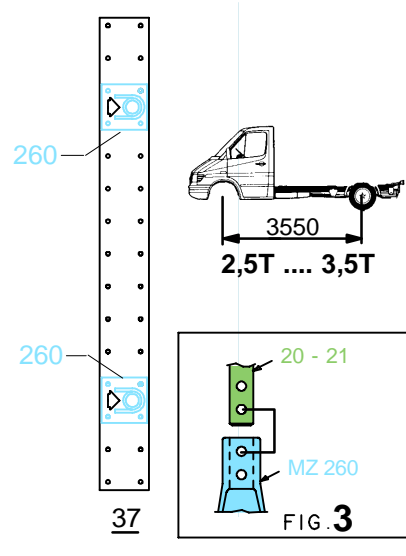

29 30 31 32 33 34 35 36 37 38 39 40 41

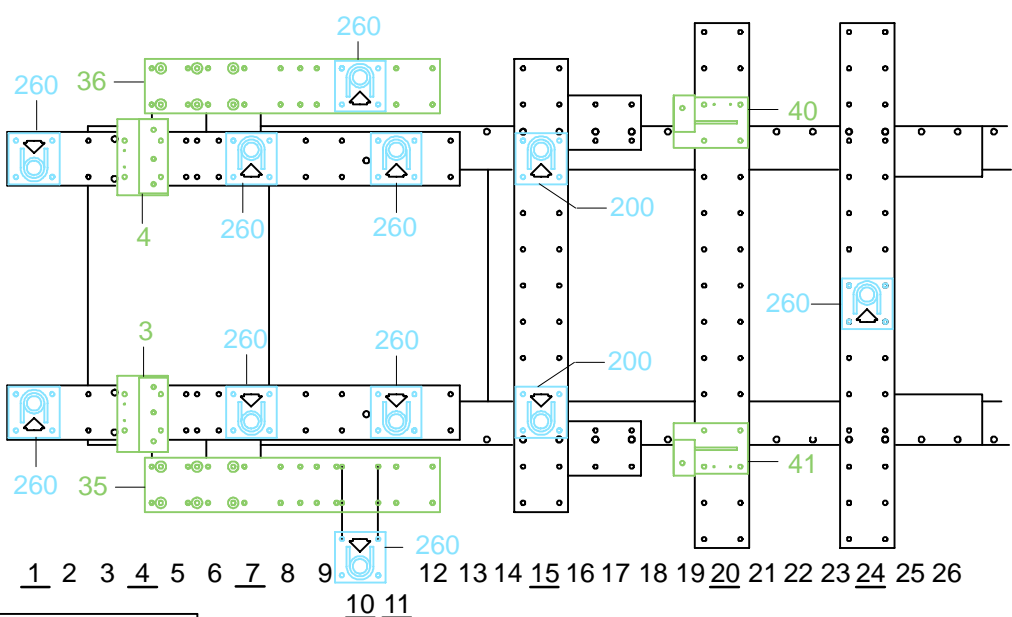
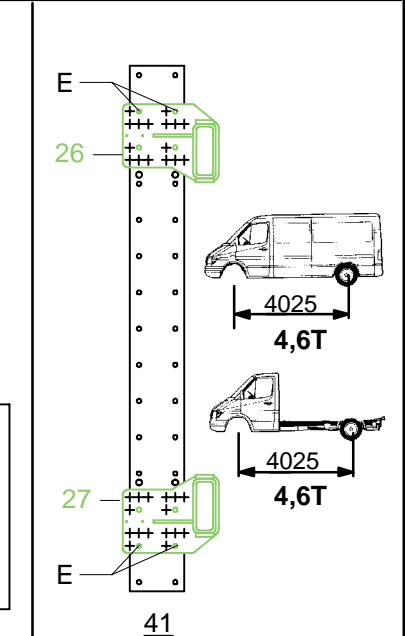
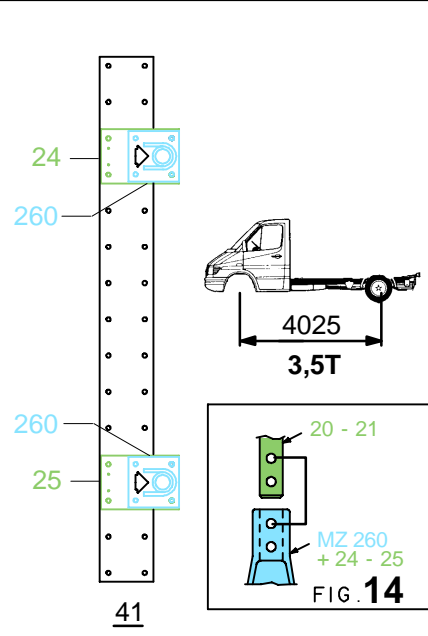

1 2 3 4 5 6 7 8 9 10 11 12 13 14 15 16 17 18 19 20 21 22 23 24 25 26

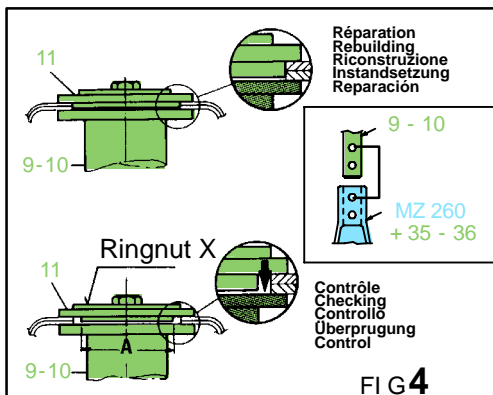
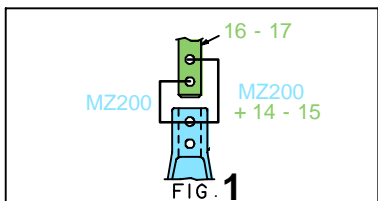
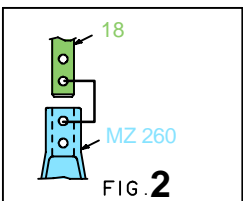

755.300

253 Kg 12.12.96 438-D-15D1

VAS 5003

Choc arrière
Rear crash
Heckreparatur
Urto posteriore
Choque trasero

Tous types
All types
Alle typen
Tutti tipi
Todos tipos

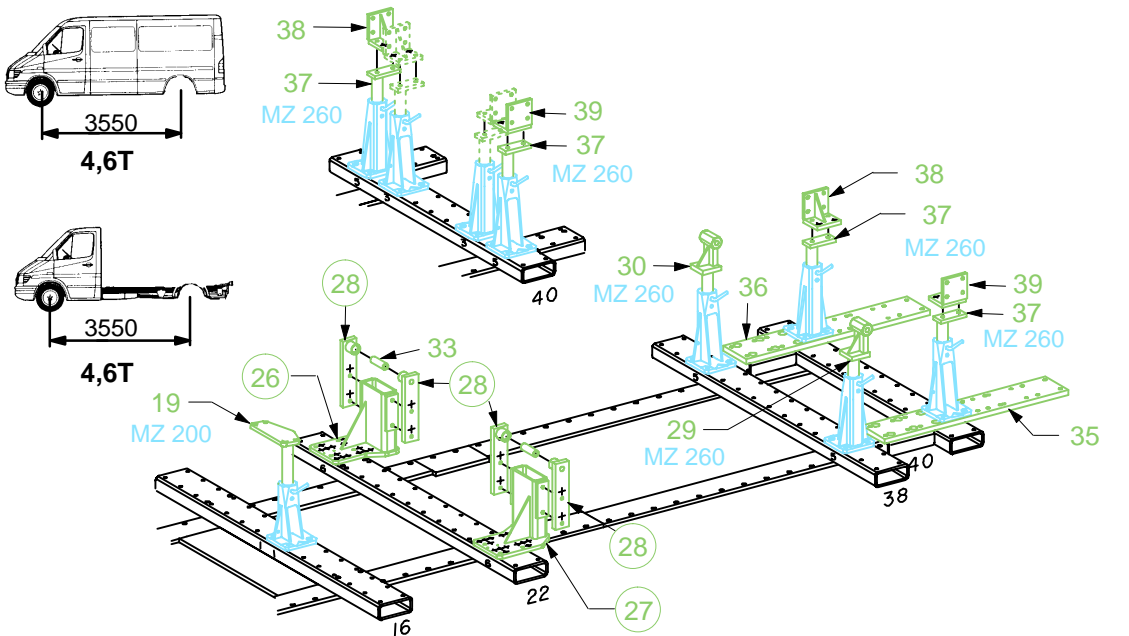
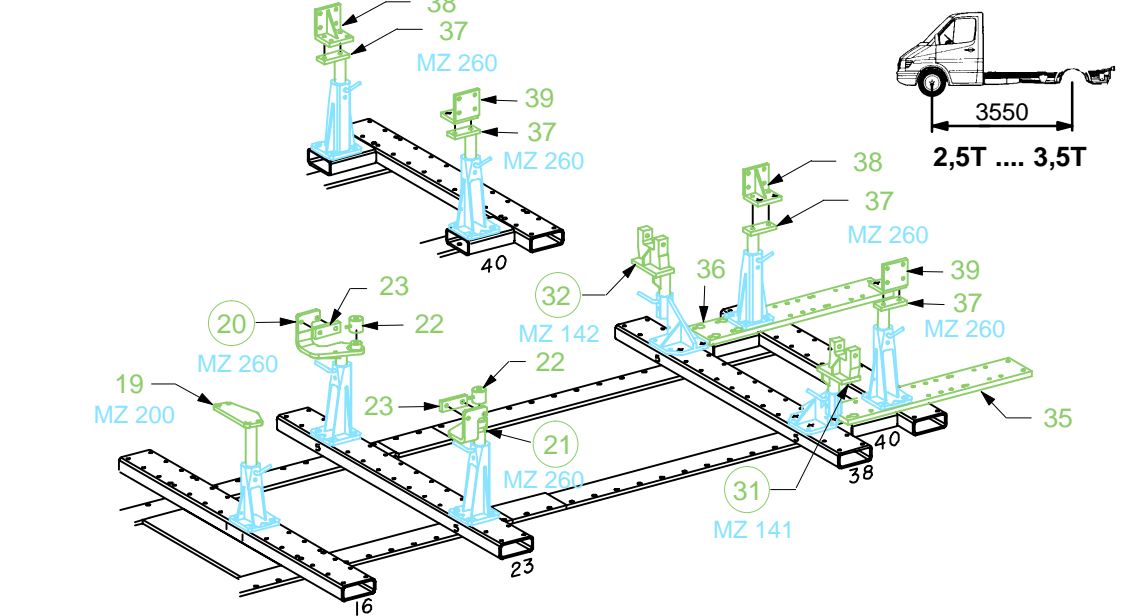
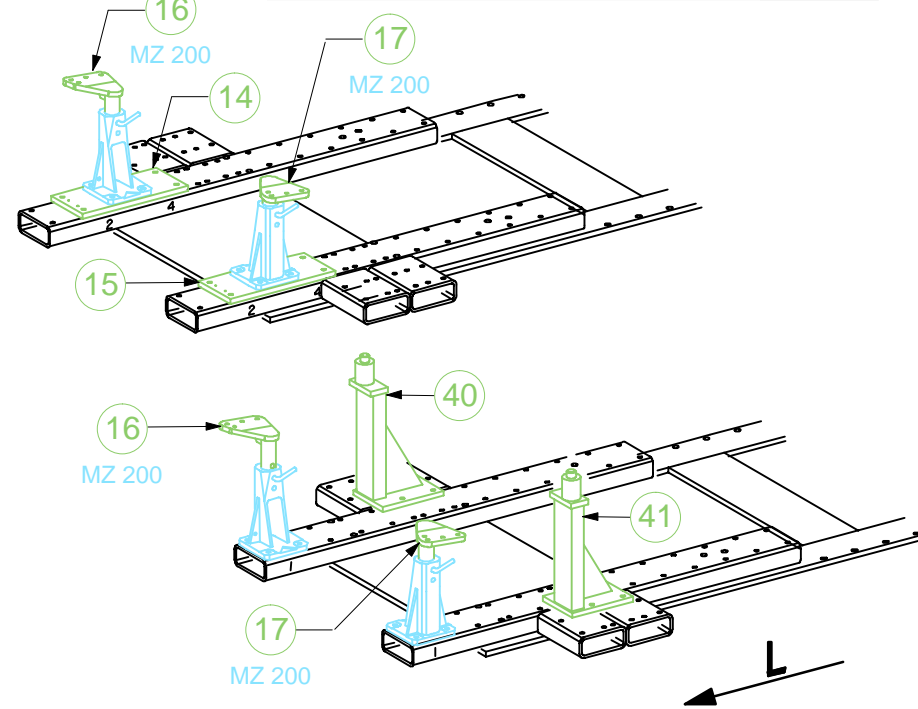
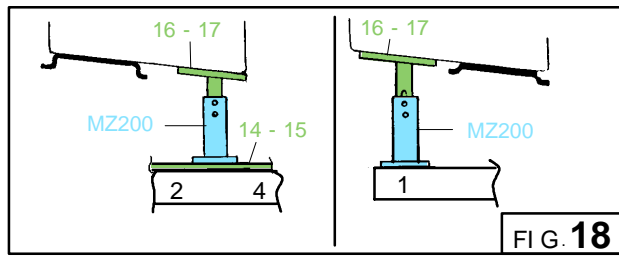
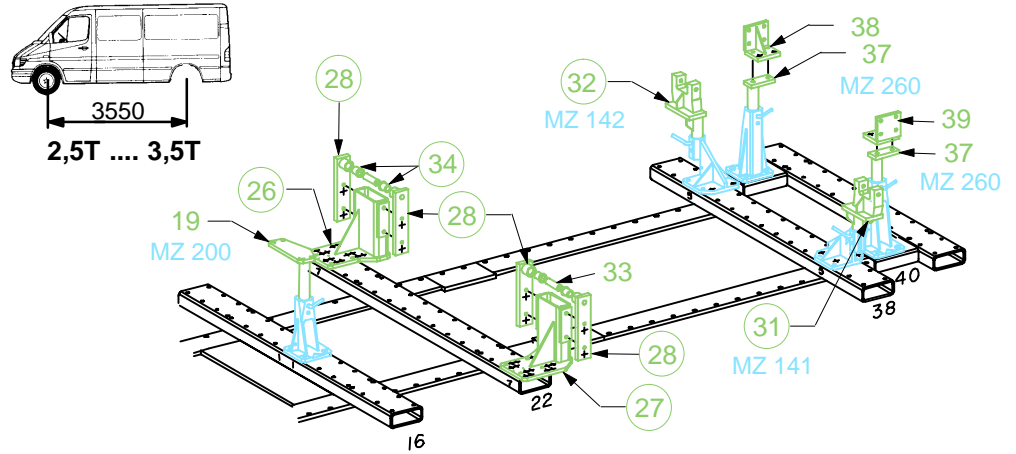
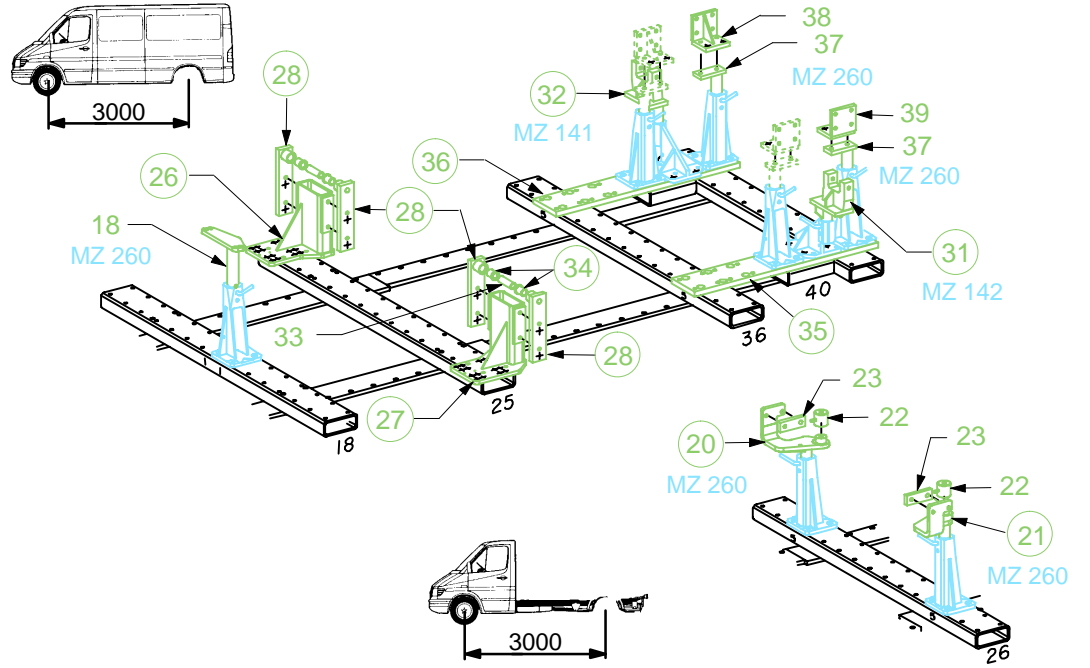
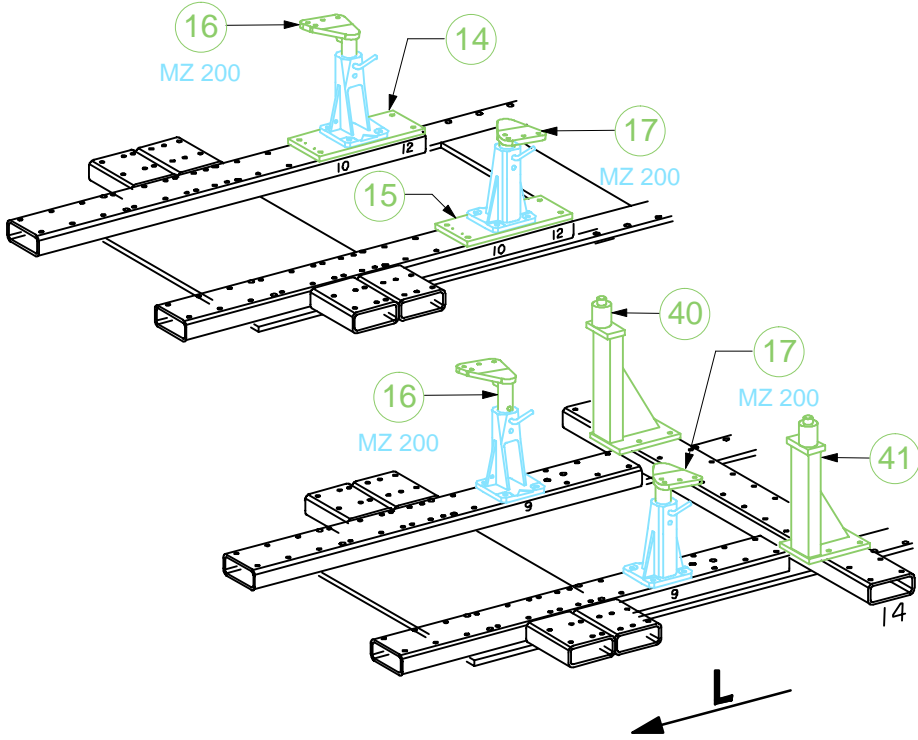
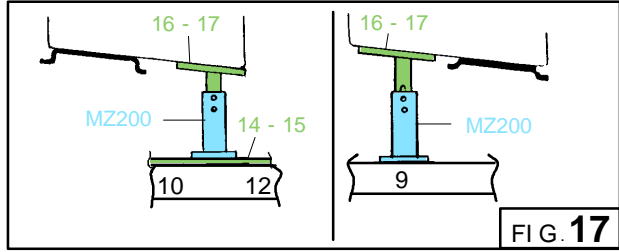

○ Avec ou sans mécanique
With or without mechanical elements
Con o senza parti meccaniche
Mit oder ohne Aggregate
Con ó sin mecánica desmontada

VAS 5003

755.300

253 Kg | 23.01.97 | 438-D-15E1



Choc arrière
Rear crash
Heckreparatur
Urto posteriore
Choque trasero

Tous types
All types
Alle typen
Tutti tipi
Todos tipos

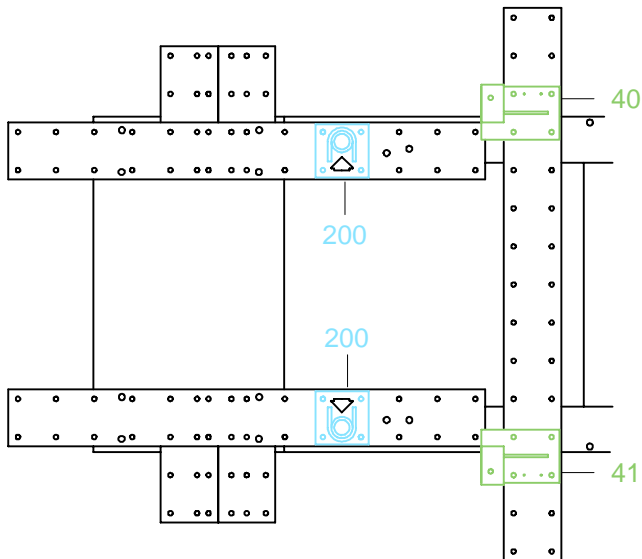

1 2 3 4 5 6 7 8 9 10 11 12 13 14 15 16

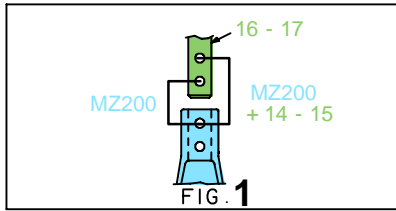
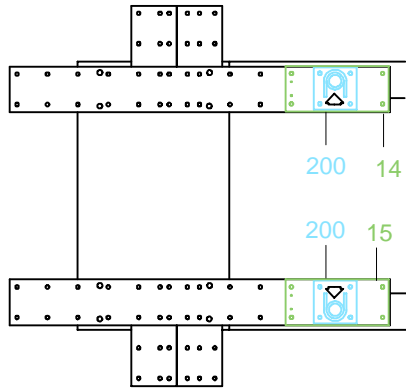

1 2 3 4 5 6 7 8 9 10 11 12

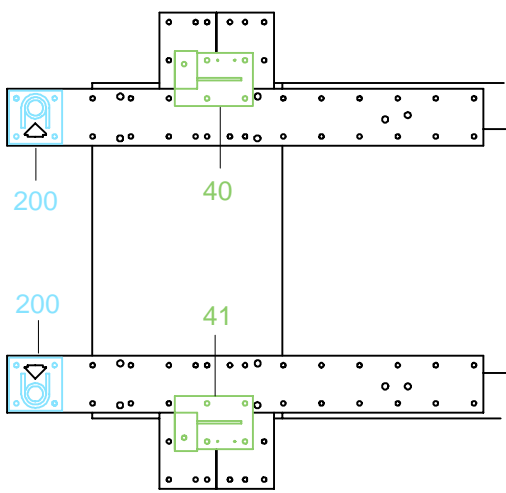

1 2 3 4 5 6 7 8 9 10 11 12

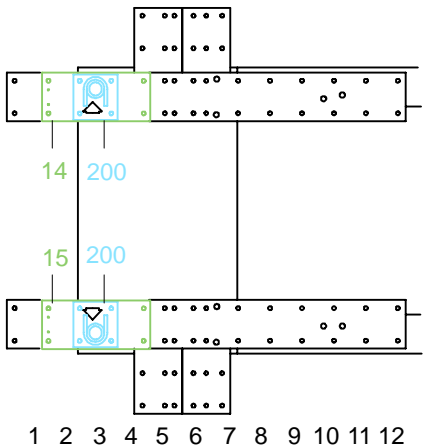

1 2 3 4 5 6 7 8 9 10 11 12

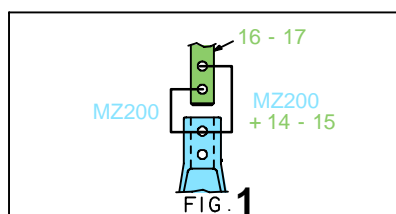

○ Avec ou sans mécanique
With or without mechanical elements
Con o senza parti meccaniche
Mit oder ohne Aggregate
Con ó sin mecanica desmontada

VAS 5003

755.300

253 Kg 12.12.96 438-D-15F1

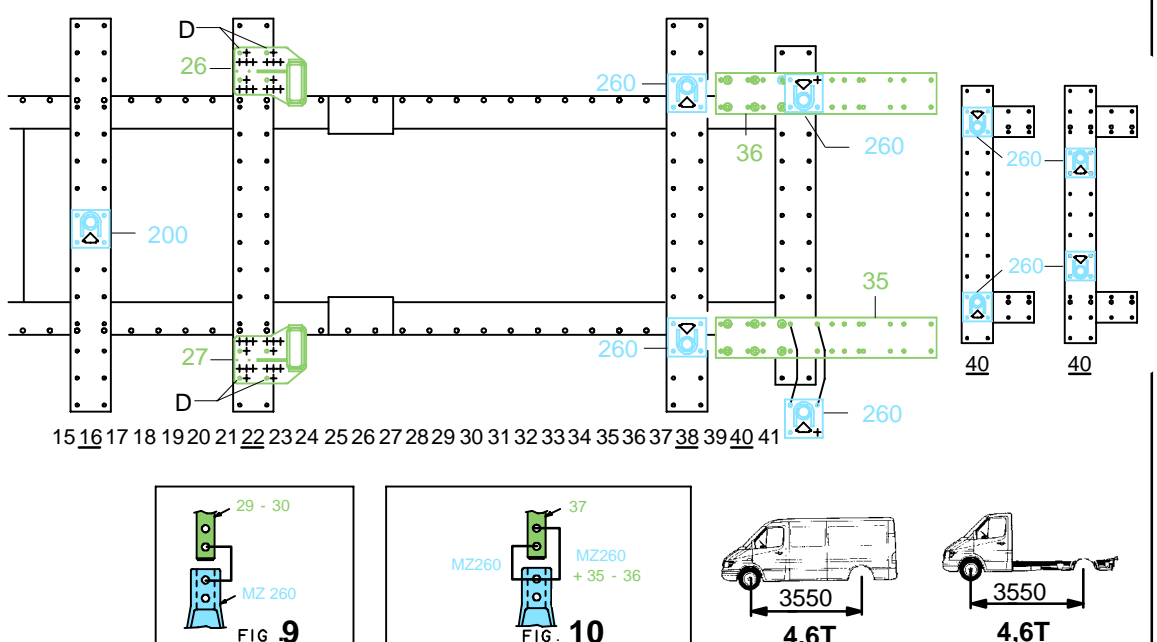
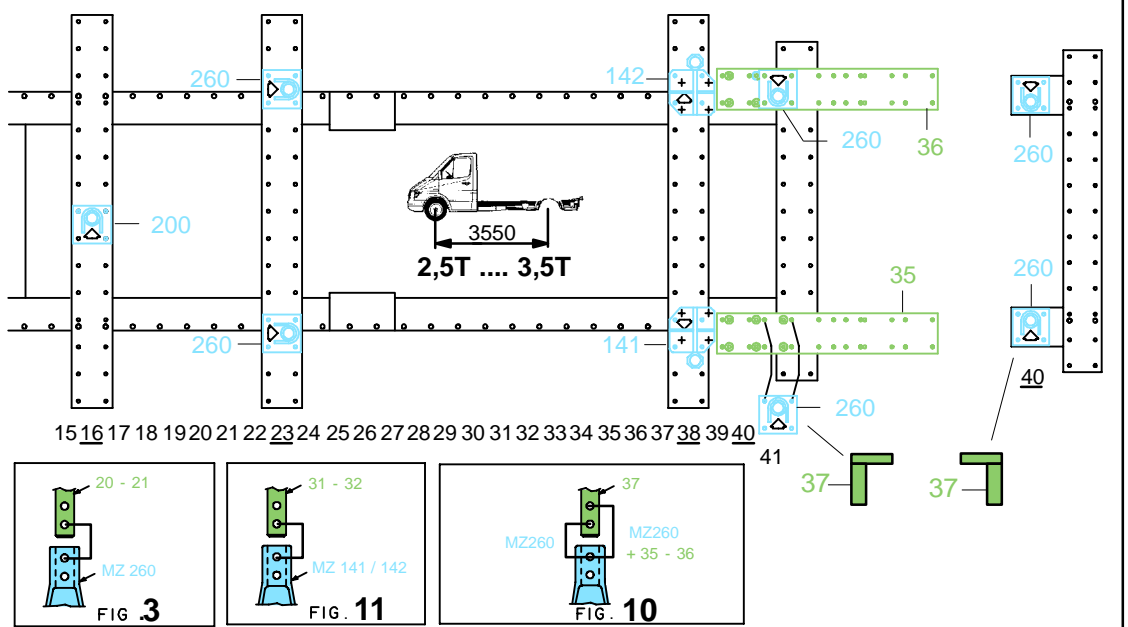
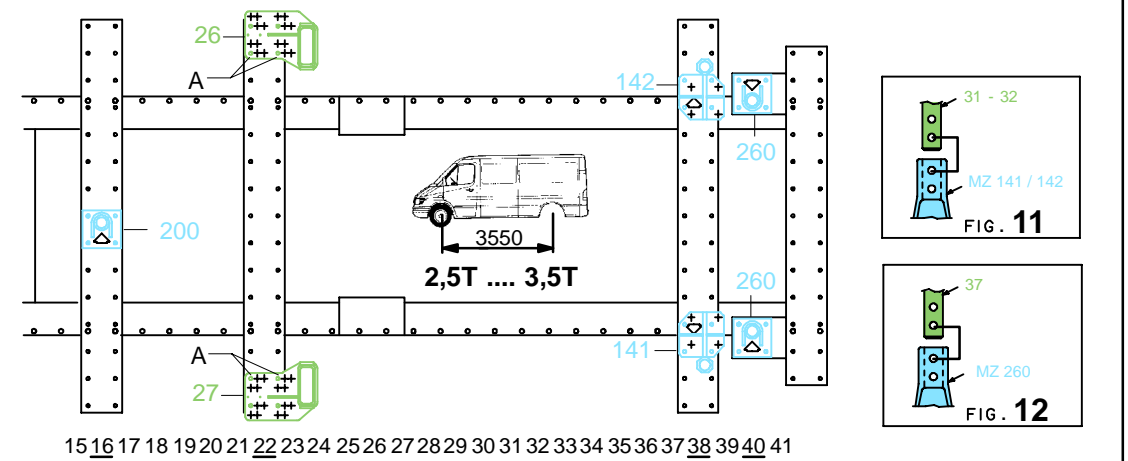
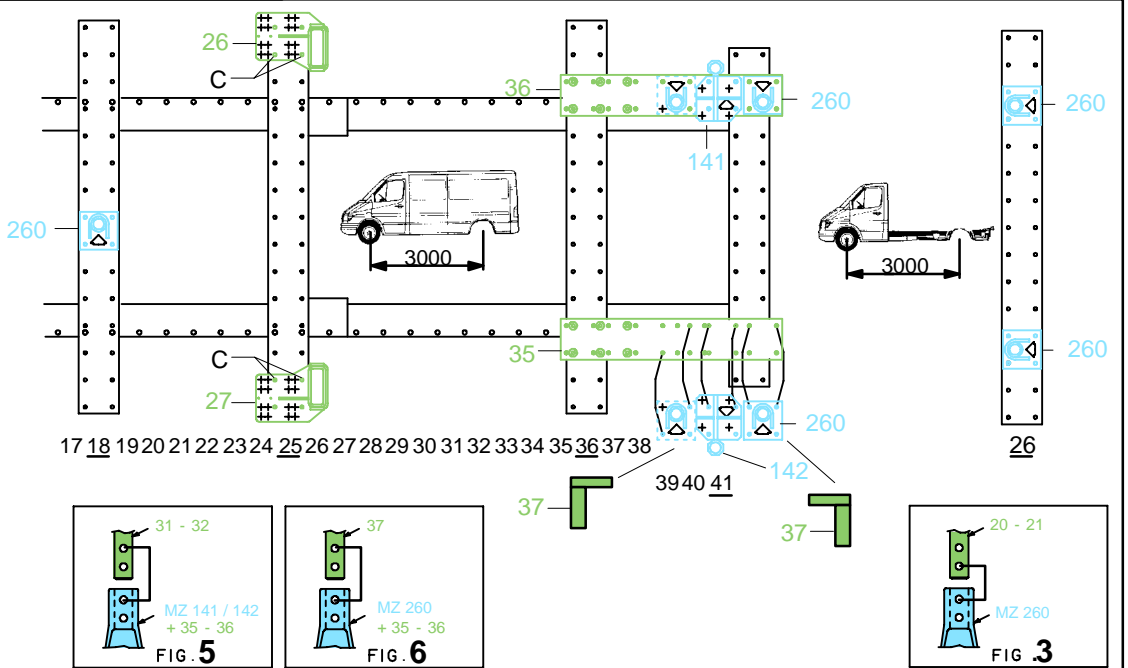

Choc arrière
Rear crash
Heckreparatur
Urto posteriore
Choque trasero

Tous types
All types
Alle typen
Tutti tipi
Todos tipos

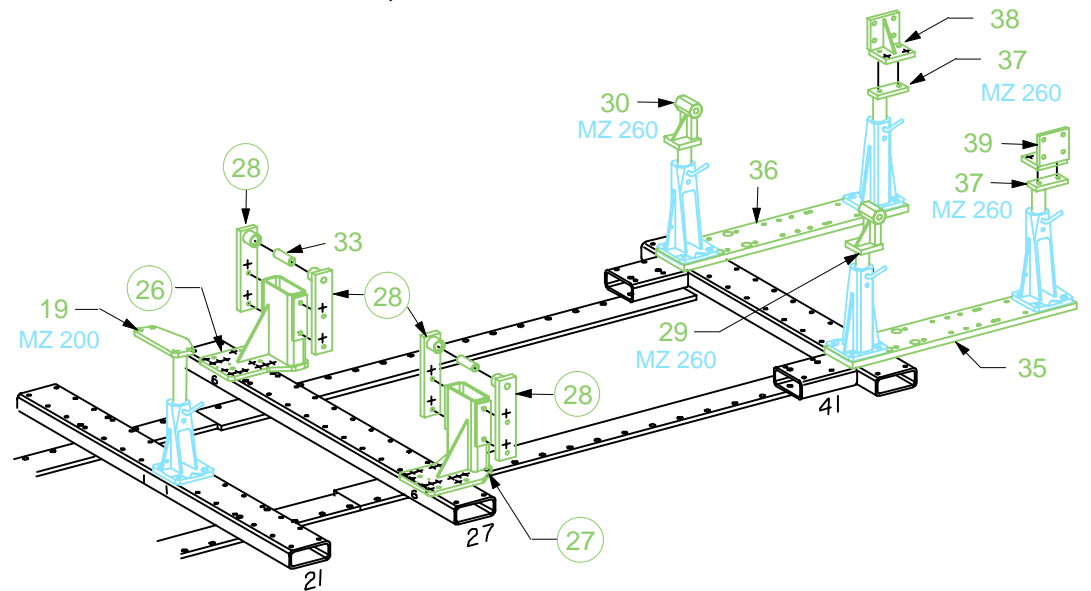
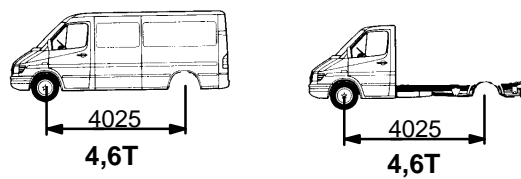
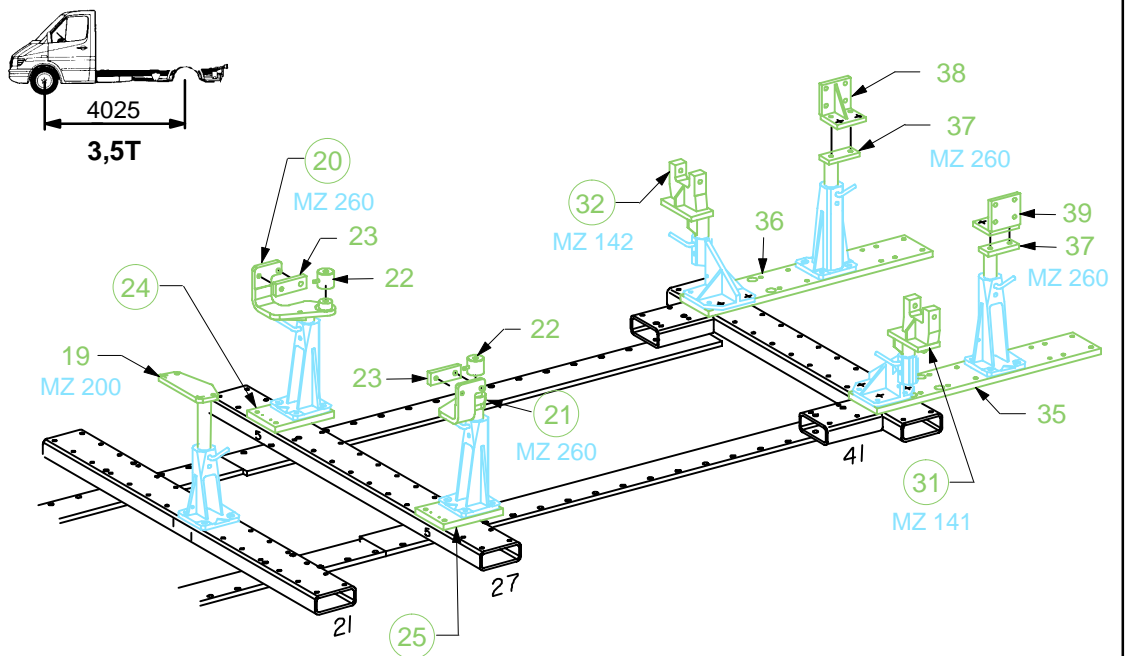
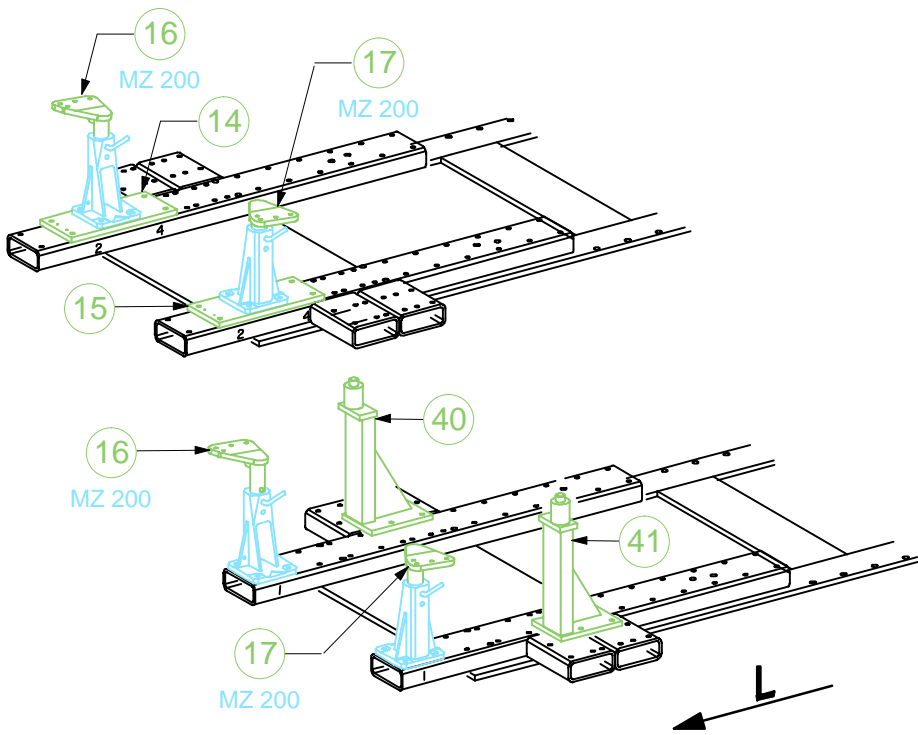
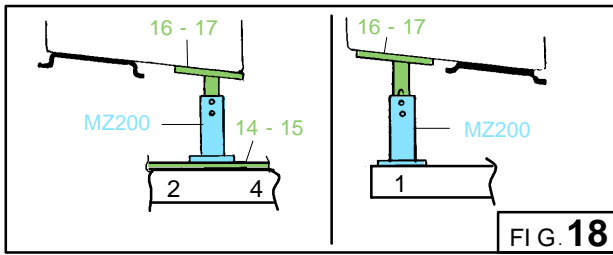
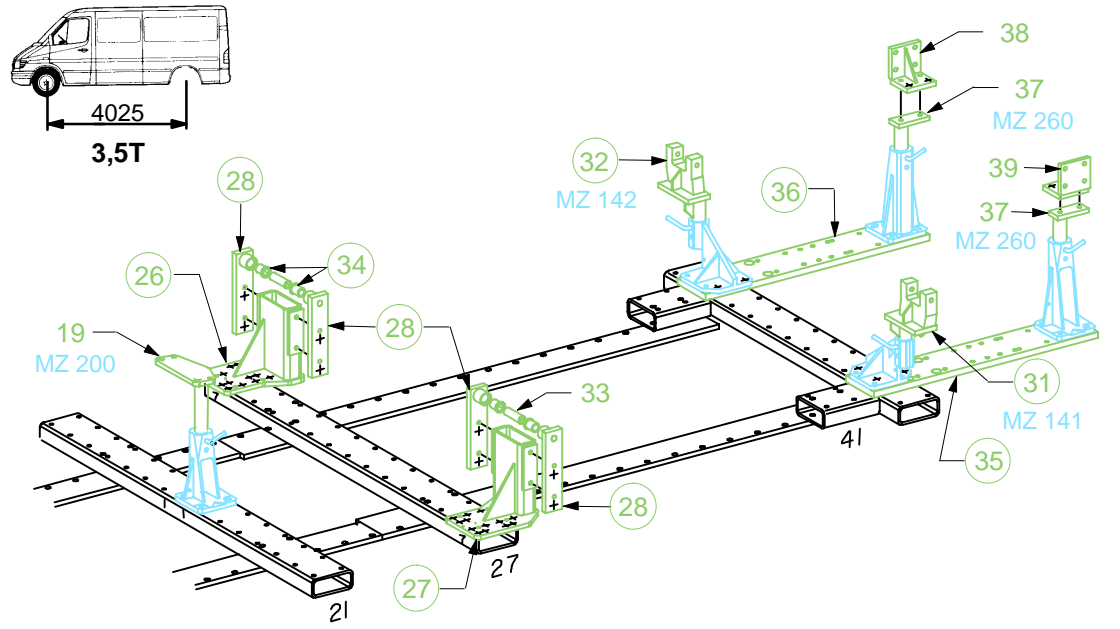

○ Avec ou sans mécanique
With or without mechanical elements
Con o senza parti meccaniche
Mit oder ohne Aggregate
Con ó sin mecánica desmontada

VAS 5003

755.300

253 Kg | 23.01.97 | 438-D-15G1



Choc arrière
Rear crash
Heckreparatur
Urto posteriore
Choque trasero

Tous types
All types
Alle typen
Tutti tipi
Todos tipos

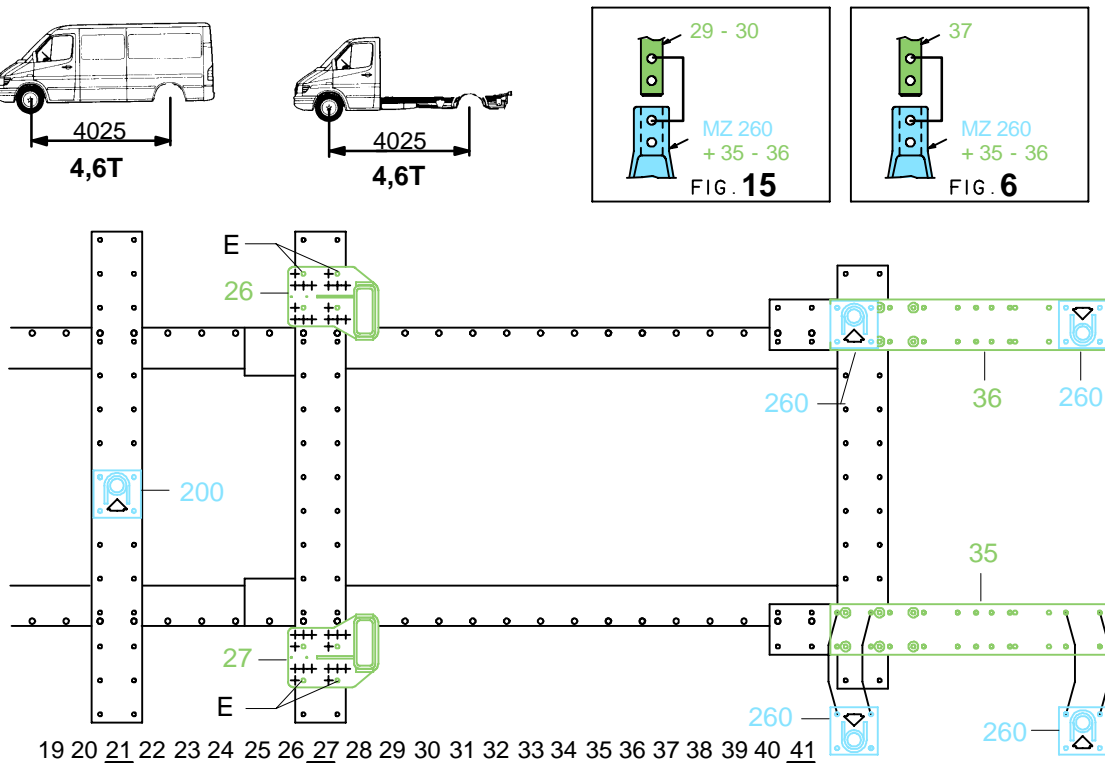
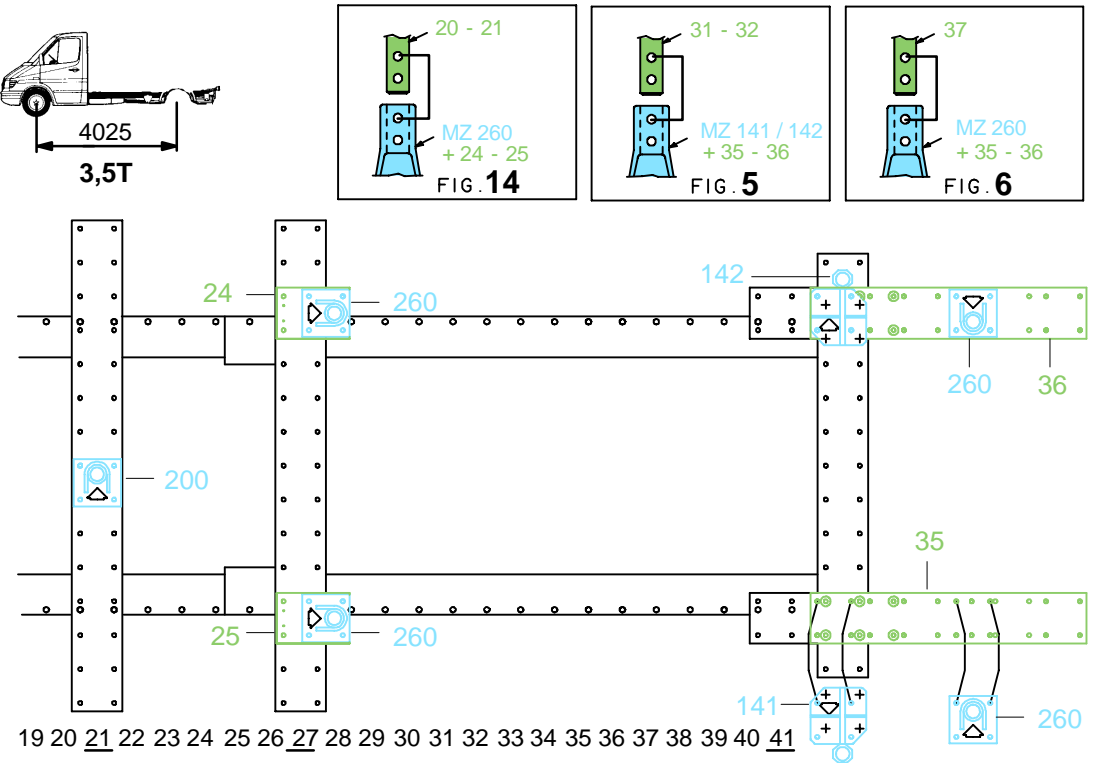
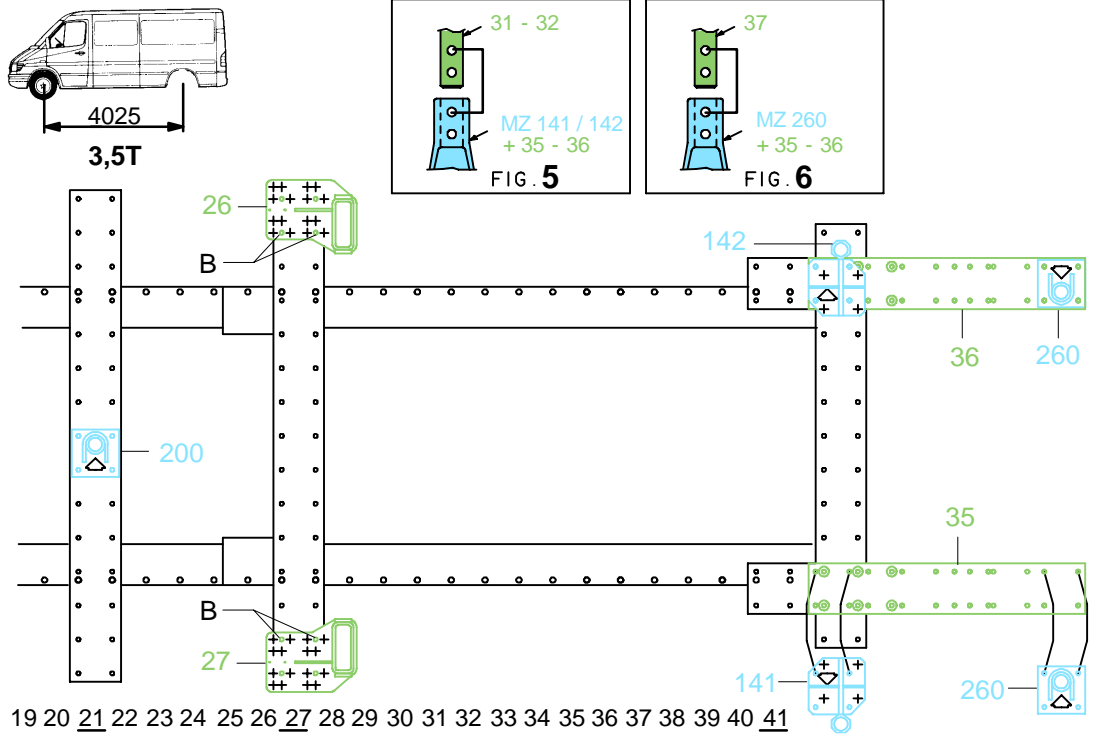
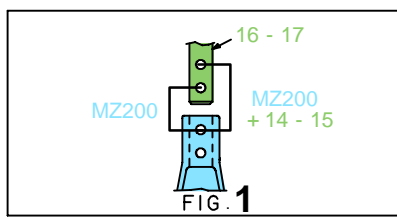
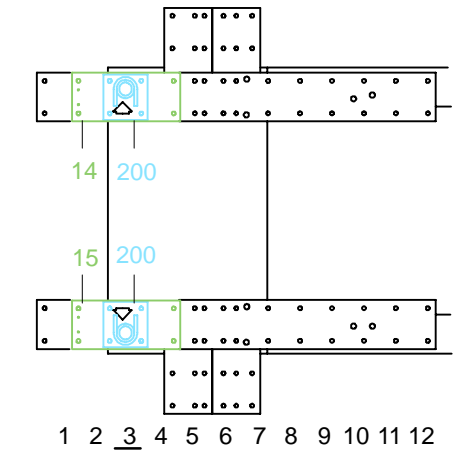
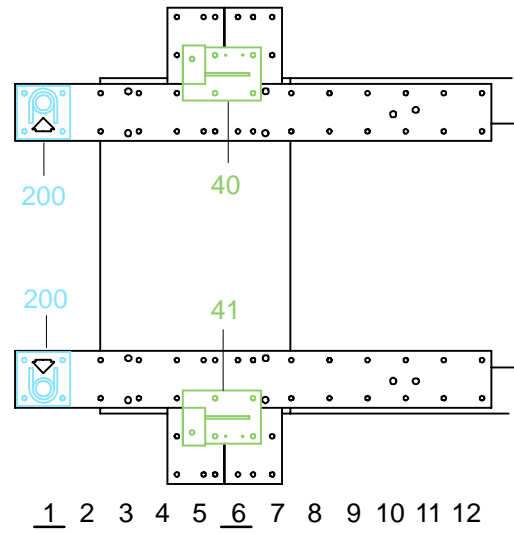

○ Avec ou sans mécanique
With or without mechanical elements
Con o senza parti meccaniche
Mit oder ohne Aggregate
Con ó sin mecánica desmontada

VAS 5003

755.300

253 Kg 12.12.96 438-D-15H1

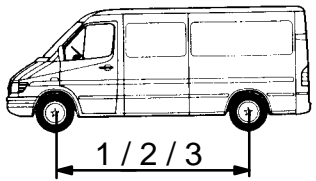
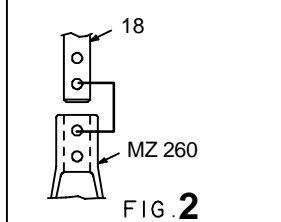
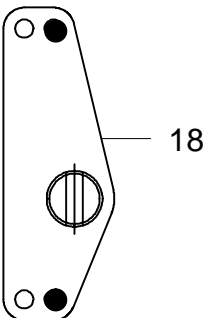
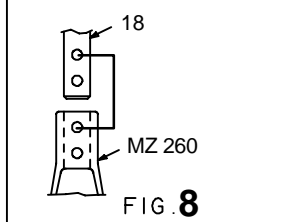
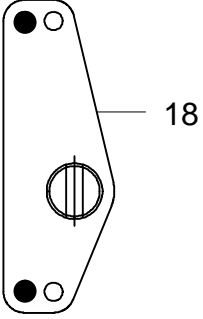
<p>Pièce 18 Aufnahme 18 Part 18 Parte 18 Pieza 18</p> <p>Cote Z Z-Maße Z dimension Dimensione Z Cota Z</p>	 <p>1 = 3000 2 = 3550 3 = 4025</p>	<p>Cote X X-Maß X dimension Dimensione X Cota X</p> <p>Disposition du perçage Lochbitzordnung Drilling location Disposizione della foratura Dispositivo del agujamiento</p>
<p>Z = - 75</p>  <p>FIG. 2</p>	<p>1 / Tous Alle All Tutti Todas</p> <p>2 / Essence Benziner Gasoline Benzina Gasolina</p> <p>3 / Tous Alle All Tutti Todas</p>	<p>X = 1435</p> 
<p>Z = - 96</p>  <p>FIG. 8</p>	<p>2 / Diesel</p>	<p>X = 1714</p> 

VAS 5003

755.300

253 Kg | 12.12.96 | 438-D-15K1

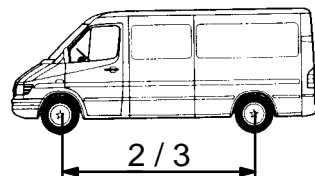
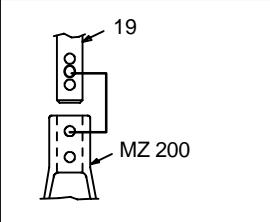
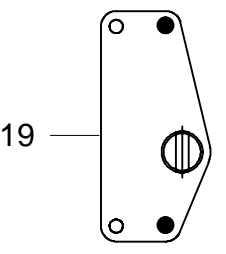
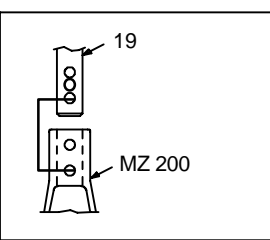
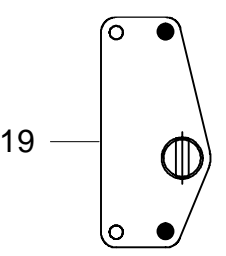
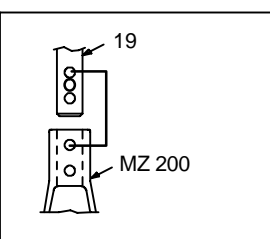
<p>Pièce 19 Aufnahme 19 Part 19 Parte 19 Pieza 19</p> <p>Cote Z Z-Maße Z dimension Dimensione Z Cota Z</p>	 <p>2 = 3550 3 = 4025</p>	<p>Ka / Kb 2,5T - 3,5T</p>	<p>Ka / Kb 4,6T</p>	<p>Fh / Doka 2,5T - 3,5T</p>	<p>Fh / Doka 4,6T</p>	<p>Cote X X-Maß X dimension Dimensione X Cota X</p> <p>Disposition du perçage Lochbitzordnung Drilling location Disposizione della foratura Dispositivo del agujamiento</p>
<p>Z = - 116</p> 	<p>2 / Essence Benziner Gasoline Benzina Gasolina</p>	<p>X</p>		<p>X</p>		<p>X = 2034</p> 
<p>Z = - 123</p> 	<p>2 / Essence Benziner Gasoline Benzina Gasolina</p> <p>3 / Tous Alle All Tutti Todas</p>		<p>X X</p>		<p>X X</p>	<p>X = 2034</p> 
<p>Z = - 149</p> 	<p>3 / Tous Alle All Tutti Todas</p>	<p>X</p>		<p>X</p>		<p>X = 2486</p> 