

○ Avec ou sans mécanique
With or without mechanical elements
Con o senza parti meccaniche
Mit oder ohne Aggregate
Con ó sin mecanica desmontada

V.A.G 1932/3



REP.	REFERENCE	PDS	NB	MZ
11	745.7011	2,5	1	
12	745.7012	2,5	1	
26	745.7026	1,7	1	080
27	745.7027	1,7	1	080
28	745.7028	2,3	1	080
29	745.7029	2,3	1	080
30	745.7030	0,3	4	
31	745.7031	2,2	1	601
32	745.7032	2,2	1	602
33	745.7033	0,4	2	
34	745.7034	2,4	1	140
35	745.7035	2,4	1	140
36	745.7036	1,1	2	
48	745.7048	0,03	4	
	V.32	0,1	2	
37	745.7037	0,08	4	
38	745.7038	1,5	1	
39	745.7039	1,5	1	
40	745.7040	4,2	1	
41	745.7041	4,2	1	
42	745.7042	1,9	1	080
43	745.7043	1,9	1	080
44	745.7044	2,8	1	
45	745.7045	2,8	1	
46	745.7046	2,7	1	
47	745.7047	2,7	1	
	T.039	0,05	2	
	B.76	0,1	2	

	"Goupille GO2" 12x30	2
	MU 12	2
	M 8x16	4
	M 12x30	2
	M 12.150x140	4
	M 6x35	4
	M 12x25	8
	CHc 12x25 TB	8
	M 10	2

complément au
complementary set to
complemento al
zusatz zu

699.300
699.400
VAG1932

745.307

55 Kg | 17.02.97 | 403-D-12E

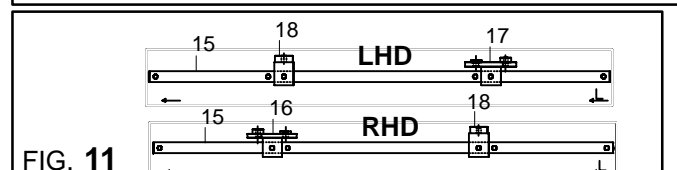
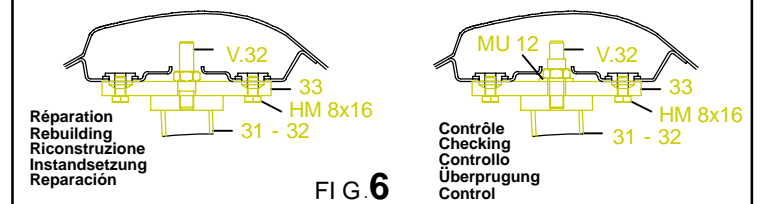
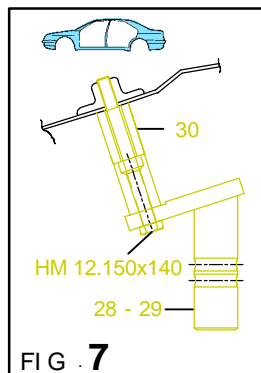
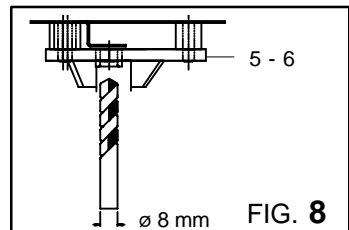
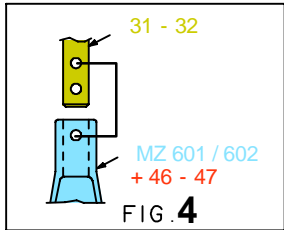
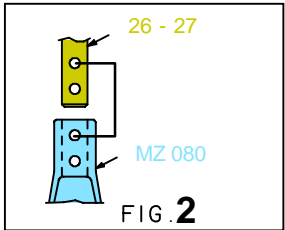
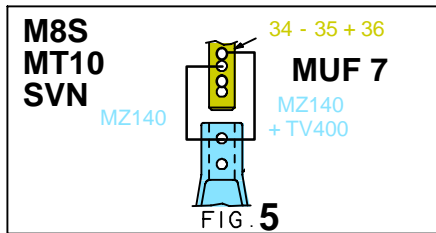
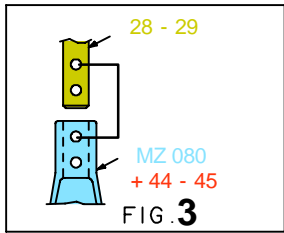
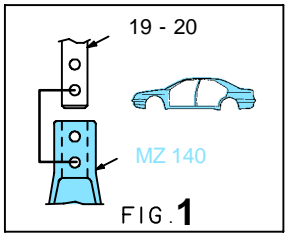
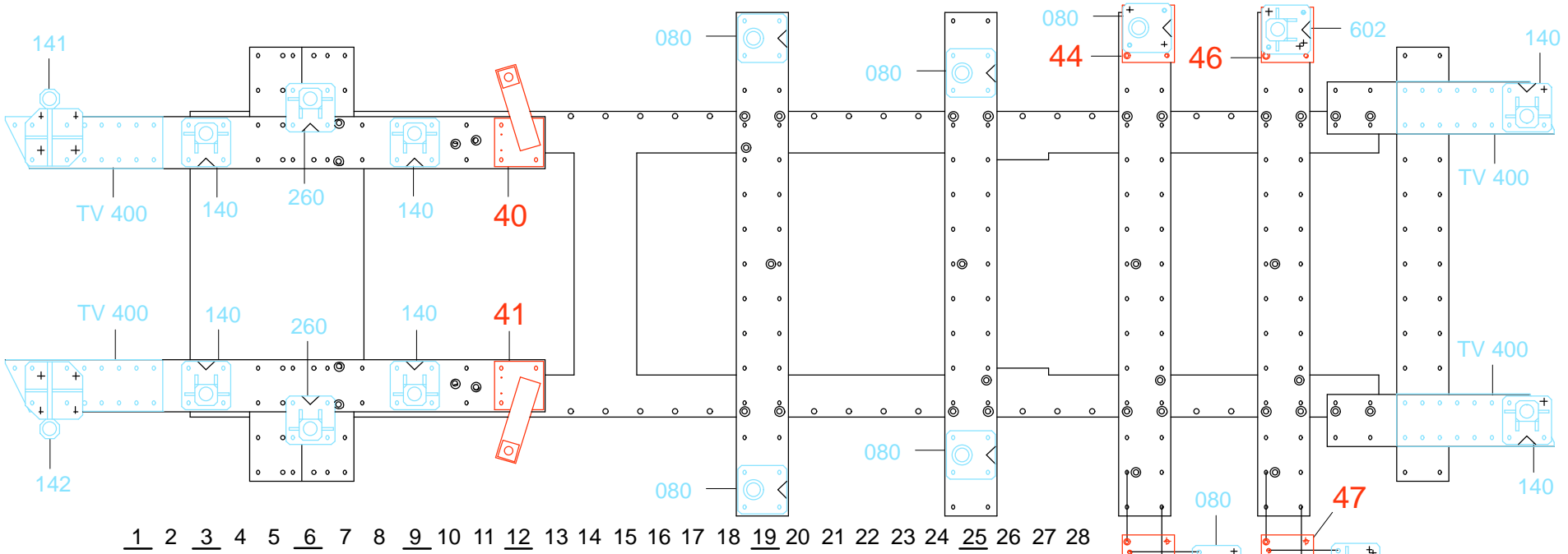

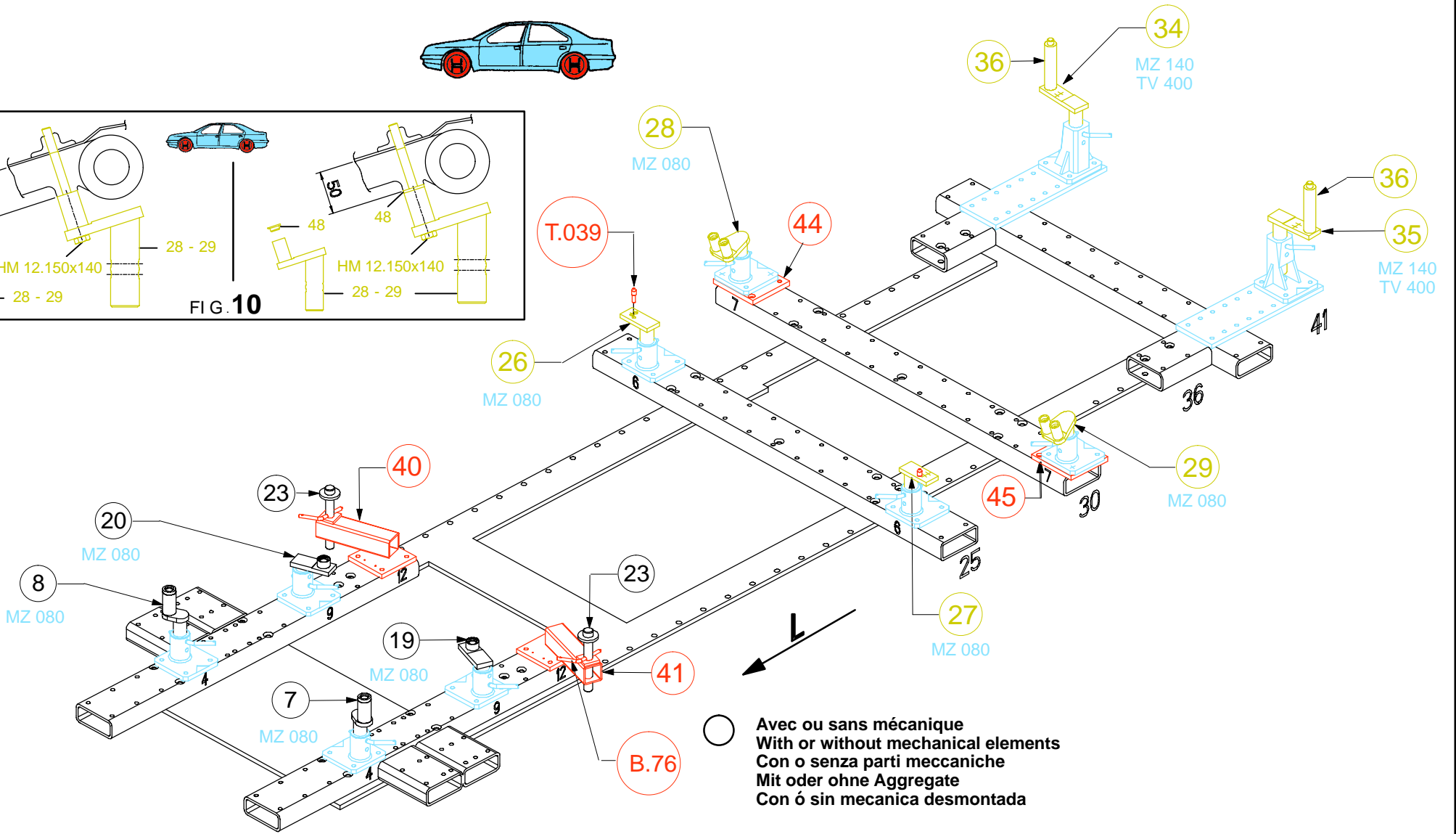
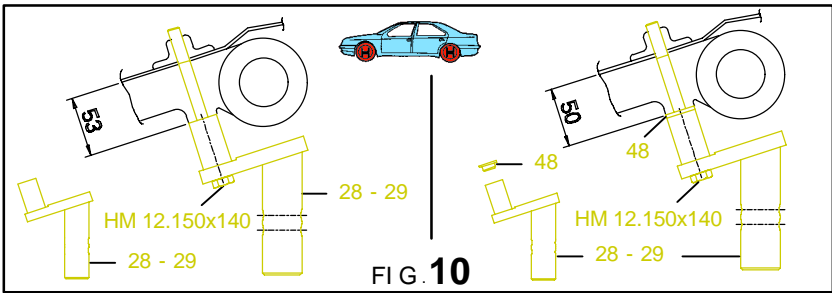
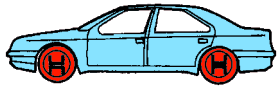

V.A.G 1932/3



745.307

55 Kg

07.05.97

403-D-12F

