

- Longeron et tole latérale déposés.
- With dismantling of the sidemember and lateral steel plate.
- Nur bei ausgebautem Längsträger und ausgebauter Seitenwand anwendbar.
- Con rimezione del longherone e della lamiera laterale.
- Larguero y lámina lateral desmontados.

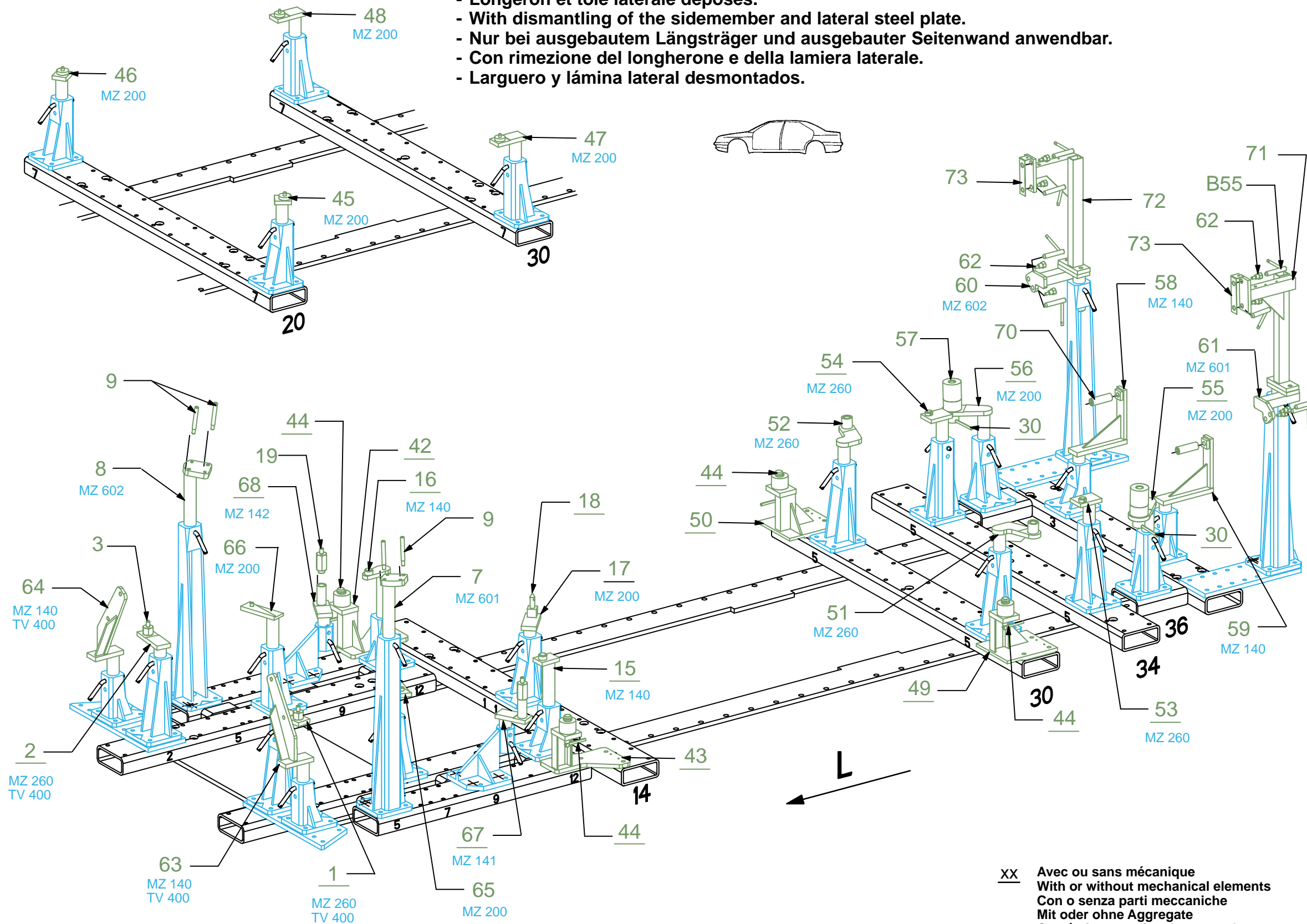
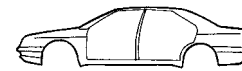

XX Avec ou sans mécanique  
With or without mechanical elements  
Con o senza parti meccaniche  
Mit oder ohne Aggregate  
Con ó sin mecanica desmontada

REP.	REFERENCE	PDS	NB	MZ
1	7414.7001	1,6	1	260/080
2	7414.7002	1,6	1	260/080
3	7168.7003	0,2	2	
4	7168.7004	1,3	2	
7	7414.7007	2,1	1	601
8	7414.7008	2,1	1	602
9	7168.7009	0,08	2	
14	7168.7014	0,6	2	
15	7414.7015	2,6	1	140
16	7414.7016	2,7	1	140
17	7414.7017	1,7	1	200
18	7168.7018	0,2	1	
19	7168.7019	0,4	2	
30	7168.7030	0,5	2	
42	7414.7042	6,0	1	
43	7414.7043	6,0	1	
44	7414.7044	0,2	4	
45	7414.7045	1,7	1	200
46	7414.7046	1,7	1	200
47	7414.7047	2,0	1	200
48	7414.7048	2,0	1	200
49	7414.7049	5,7	1	
50	7414.7050	5,7	1	
51	7414.7051	2,6	1	260
52	7414.7052	2,6	1	260
53	7414.7053	2,1	1	260
54	7414.7054	2,1	1	260
55	7414.7055	3,0	1	200
56	7414.7056	3,0	1	200
57	7414.7057	1,2	2	
58	7414.7058	3,1	1	140
59	7414.7059	3,1	1	140
60	7414.7060	2,4	1	602
61	7414.7061	2,4	1	601
62	7414.7062	0,1	8	
63	7414.7063	3,7	1	140
64	7414.7064	3,7	1	140
65	7414.7065	2,4	1	200
66	7414.7066	2,4	1	200
67	7414.7067	1,7	1	141/080
68	7414.7068	1,7	1	142/080
69	7414.7069	0,2	2	
70	7414.7070	0,2	2	
71	7414.7071	2,4	1	
72	7414.7072	2,4	1	
73	7414.7073	0,02	2	
75	7414.7075 B55	1,0	1	
		0,2	8	

	M 8-20	4
	M 12-25	8
	M 12-30	4
	M 12-90	2
	M 14-35	2
	M 14-120	2
	M 16-20	2
	M 12x1,50-50	2
	M 12x1,50-140	2
	M 12x1,50	2
	M 12	4
	M 14	2
	LU 12	6

# 7414.300

## MERCEDES BENZ

107 Kg | 29.01.2003 | 420-D-24F

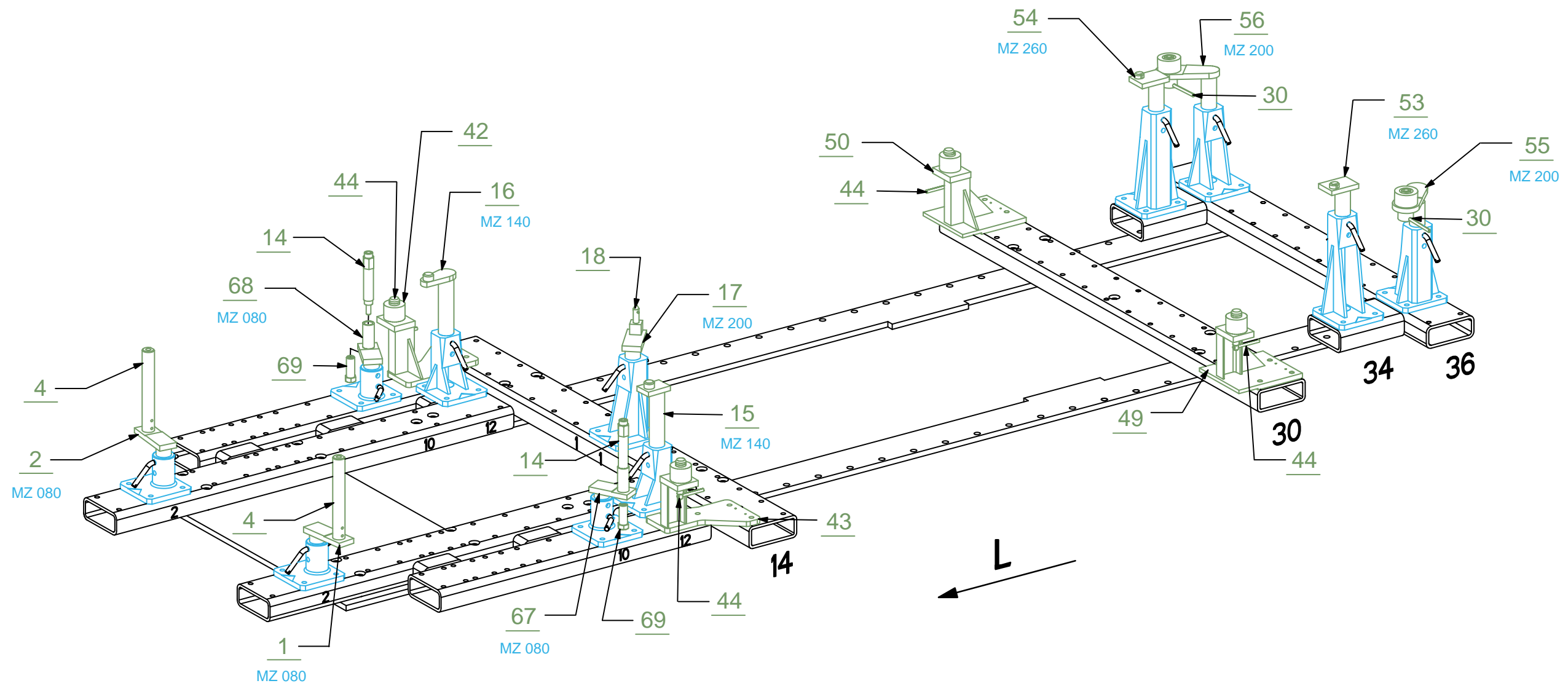

XX Avec ou sans mécanique  
 With or without mechanical elements  
 Con o senza parti meccaniche  
 Mit oder ohne Aggregate  
 Con ó sin mecanica desmontada

**MERCEDES BENZ**

**7414.300**

107 Kg | 14.11.2001 | 420-D-24G

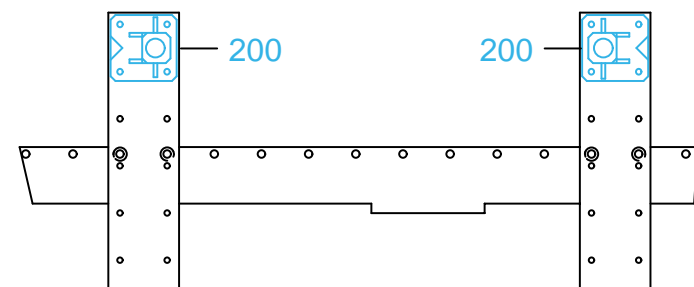
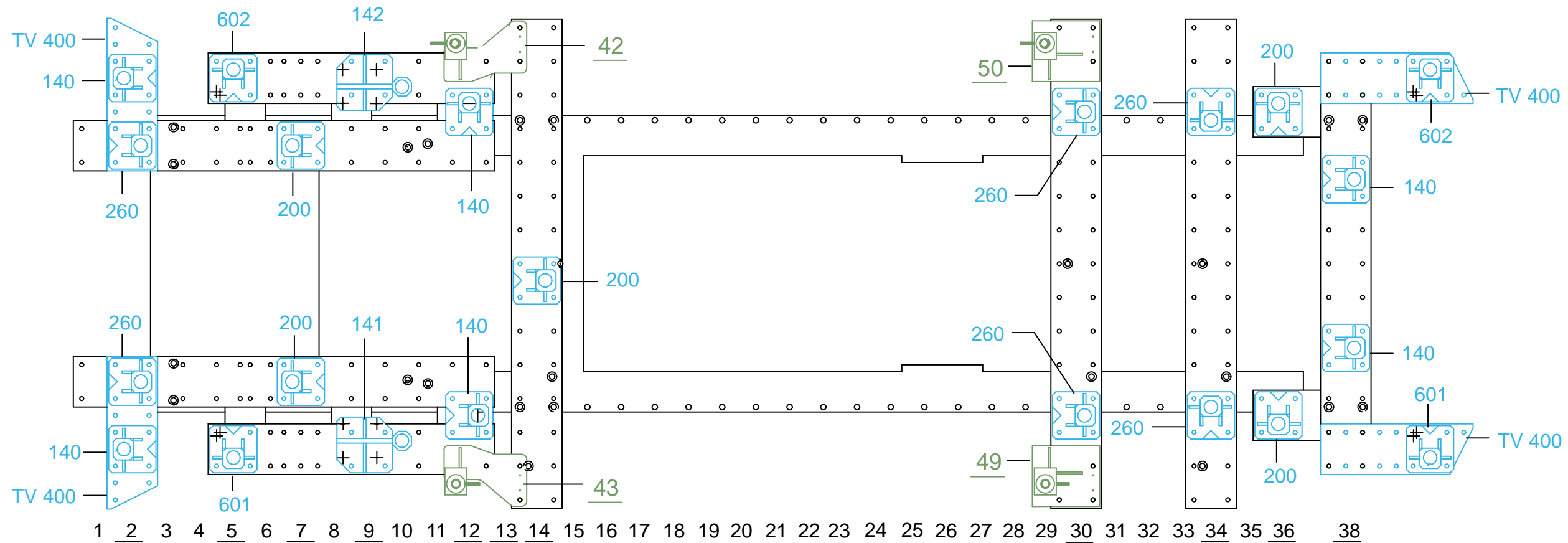
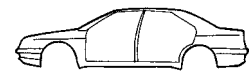

- Longeron et tole latérale déposés.
- With dismantling of the sidemember and lateral steel plate.
- Nur bei ausgebautem Längsträger und ausgebauter Seitenwand anwendbar.
- Con rimezione del longherone e della lamiera laterale.
- Larguero y lámina lateral desmontados.

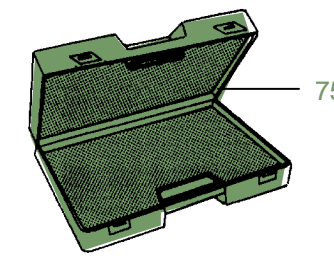
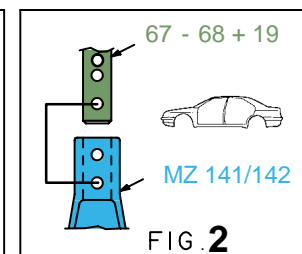
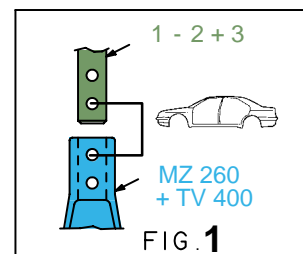
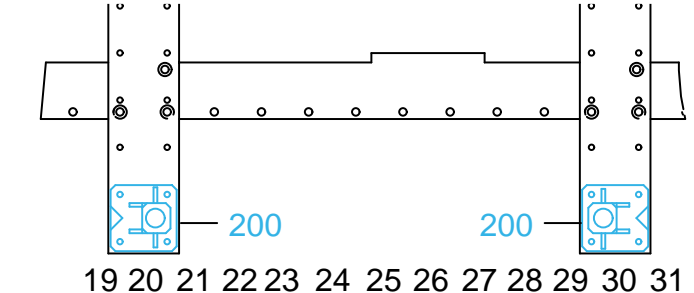

**XX** Avec ou sans mécanique  
 With or without mechanical elements  
 Con o senza parti meccaniche  
 Mit oder ohne Aggregate  
 Con ó sin mecanica desmontada

**7414.300**

107 Kg	14.11.2001	420-D-24H
--------	------------	-----------

**MERCEDES BENZ**

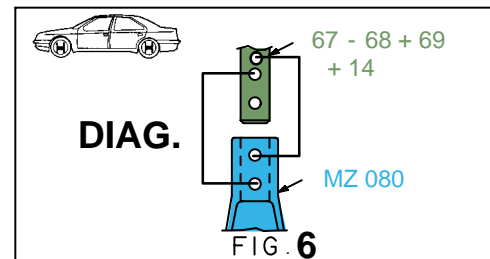
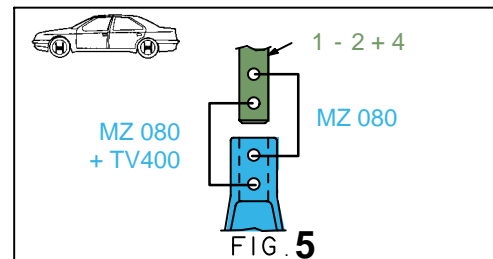
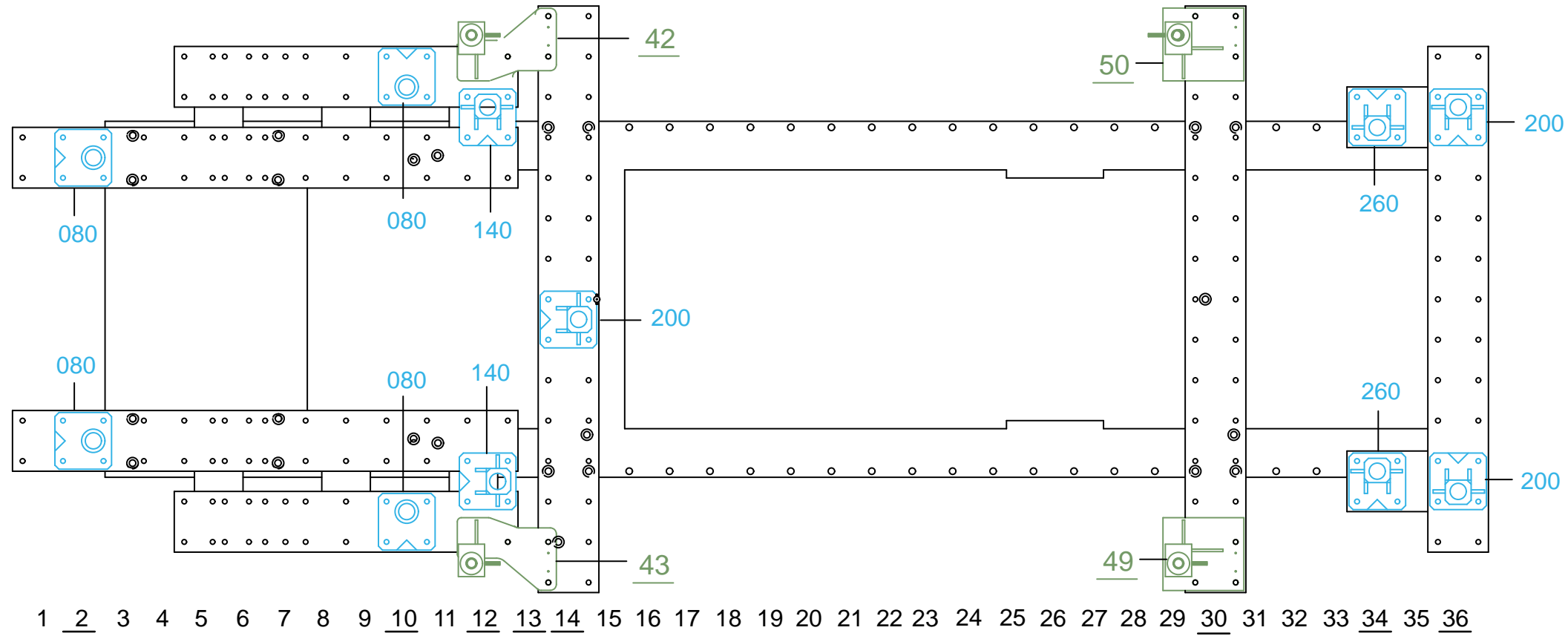

XX Avec ou sans mécanique  
 With or without mechanical elements  
 Con o senza parti meccaniche  
 Mit oder ohne Aggregate  
 Con ó sin mecanica desmontada

**MERCEDES BENZ**

**7414.300**

107 Kg | 14.11.2001 | 420-D-24K

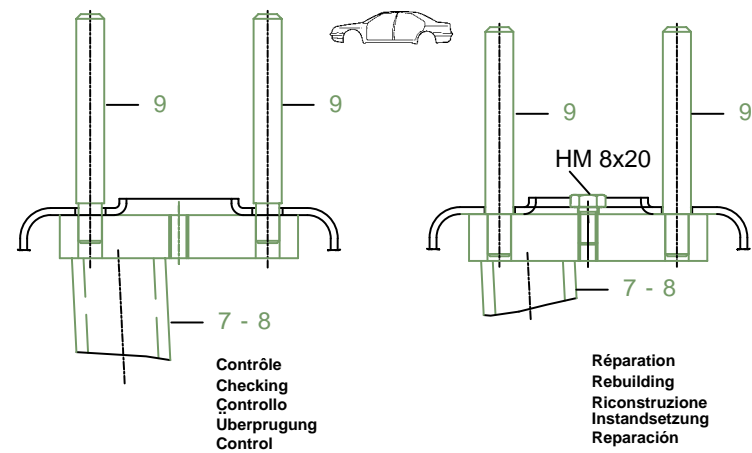

**FIG. 4**

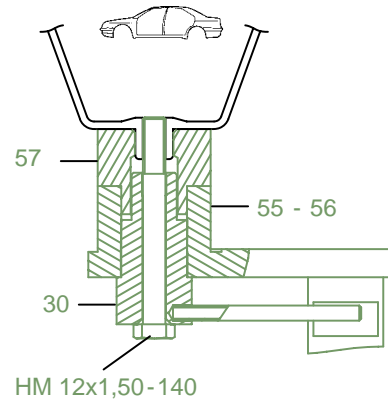

**FIG. 3**

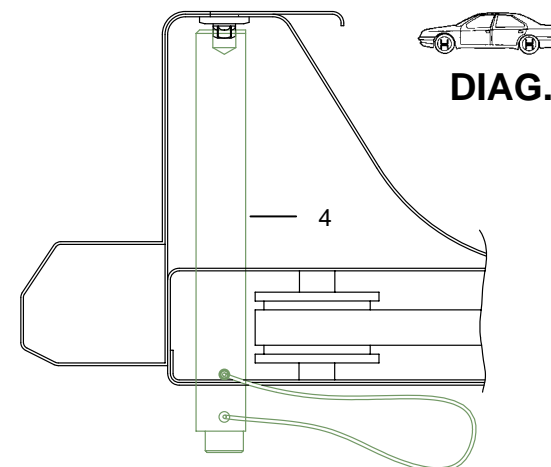

**FIG. 7**

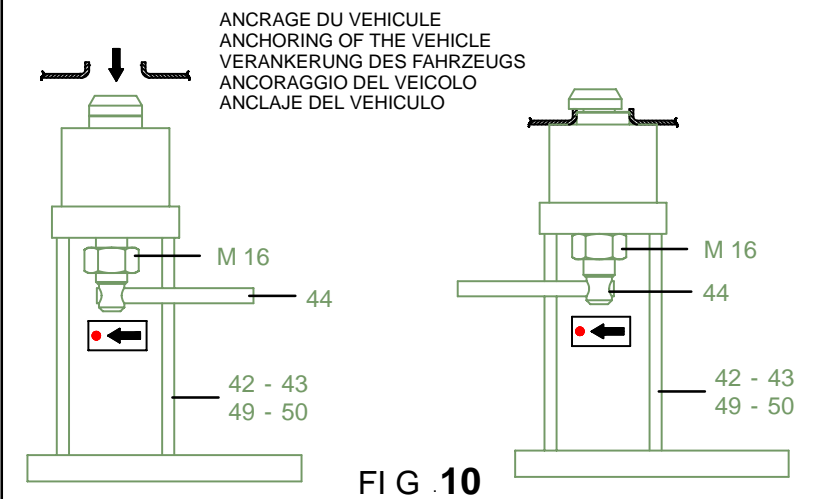

**FIG. 10**

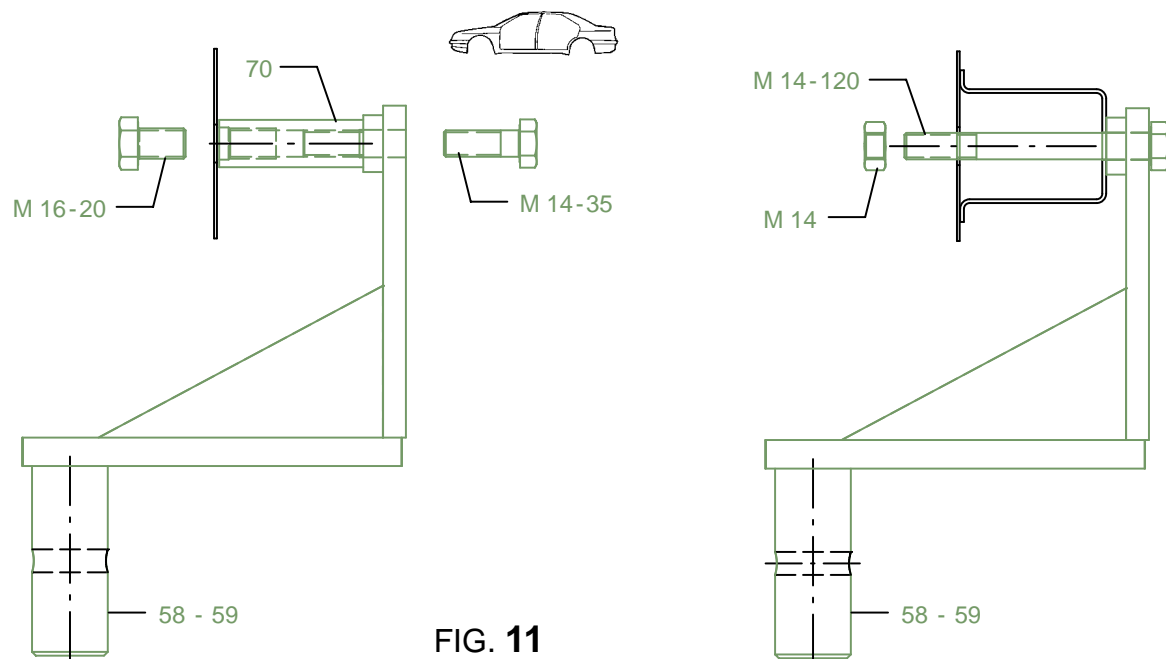

**FIG. 11**

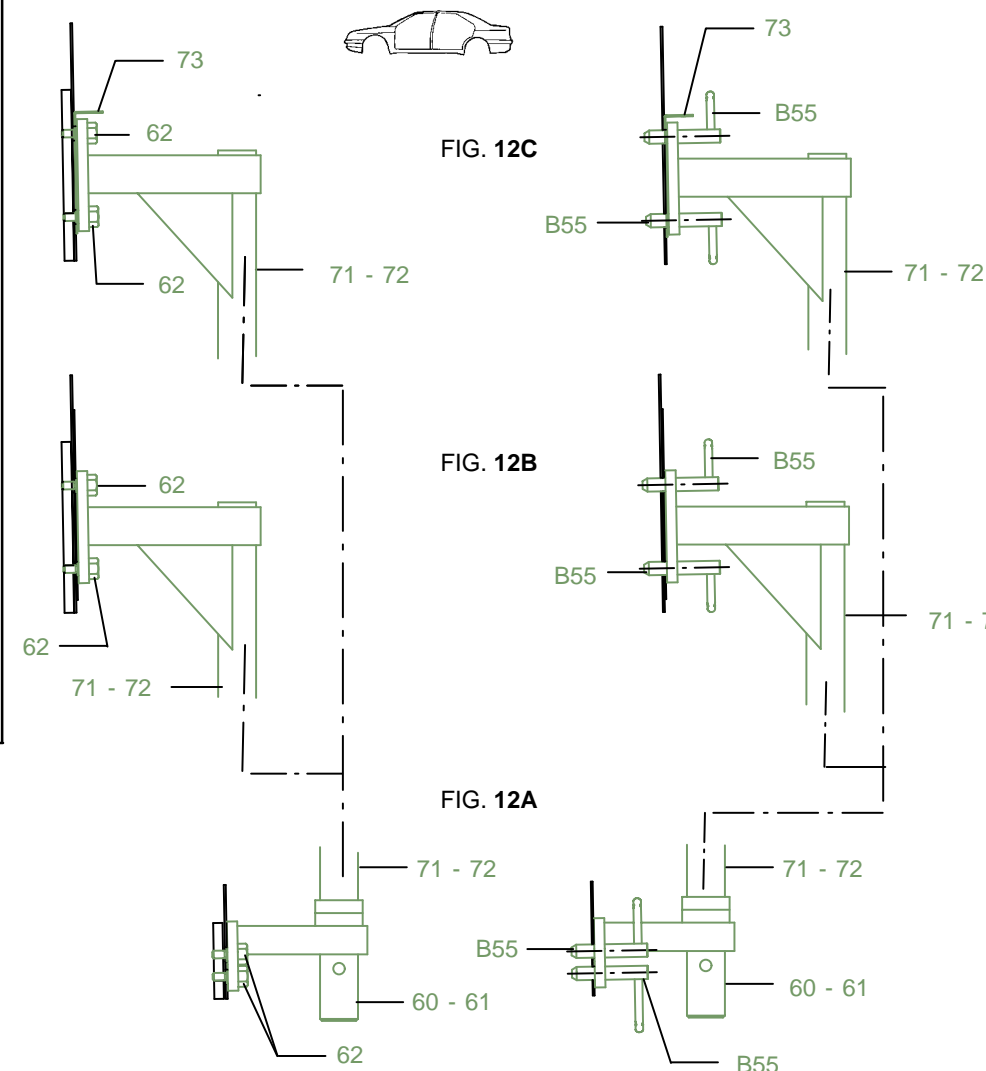

**FIG. 12**

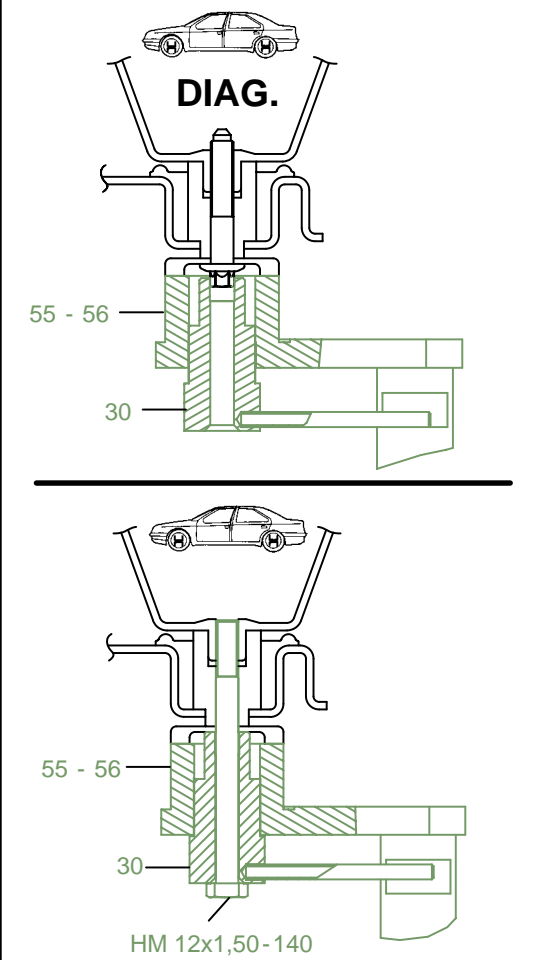

**FIG. 9**

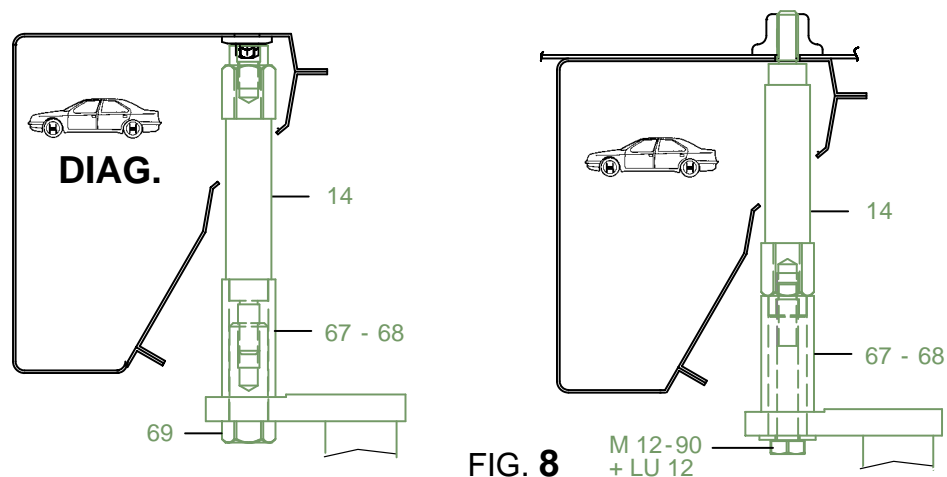

**FIG. 8**

**MERCEDES BENZ**

**7414.300**

107 Kg | 14.11.2001 | 420-D-24L