

○ Avec ou sans mécanique
With or without mechanical elements
Con o senza parti meccaniche
Mit oder ohne Aggregate
Con ó sin mecanica desmontada

RENAULT

REP.	REFERENCE	PDS	NB	MZ
1	741.7001	2.6	1	142
2	741.7002	2.6	1	141
3	741.7003	2.0	1	
4	741.7004	2.0	1	
5	741.7005	2.4	1	
6	741.7006	2.4	1	
7	741.7007	3.1	1	260
8	741.7008	2.0	1	601
9	741.7009	2.4	1	260
10	741.7010	2.4	1	260
11	741.7011	0.3	2	
12	741.7012	2.0	1	602
13	741.7013	2.0	1	601
14	741.7014	1.1	1	
15	741.7015	1.1	1	
16	741.7016	1.9	1	140/080
17	741.7017	1.9	1	140/080
18	741.7018	0.1	2	
19	741.7019	3.4	1	601
20	741.7020	3.4	1	602
21	741.7021	1.6	1	
22	741.7022	1.6	1	
23	741.7023	3.7	2	
24	741.7024	1.3	1	200
25	741.7025	1.3	1	200
26	741.7026	2.7	1	140
27	741.7027	2.7	1	140
28	741.7028	1.0	2	
29	741.7029	1.0	2	
30	741.7030	2.6	1	260
31	741.7031	2.6	1	260
32	741.7032	3.2	1	140
33	741.7033	3.1	1	260
34	741.7034	0.1	2	
35	741.7035	0.8	1	
	V11	0.1	2	
	V32	0.1	2	
	E19	0.1	2	

955.714	4
M 8x80	2
M 8x100	2
M 10x16	2
M 10x30	4
M 12x20	6
M 12x25	14
M 12x30	2
M 12x60	4
M 14x130	2
CHc 12x25	8
M10	2
M12	2
M14	2
MU 10	2
MU 12	2
LU 12	2

741.300

79 Kg | 27.09.96 | 427-D-24A

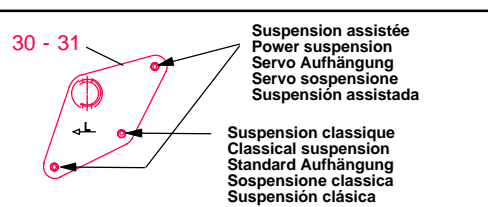
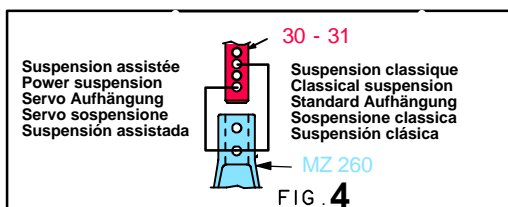
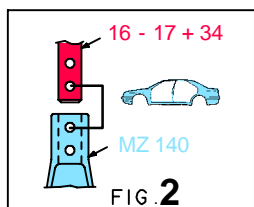
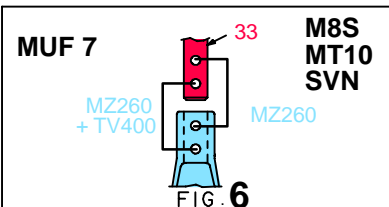
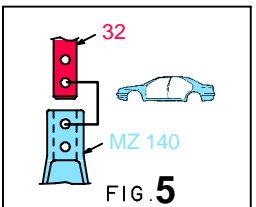
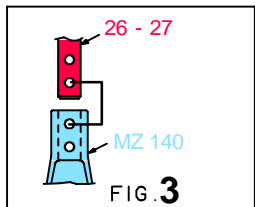
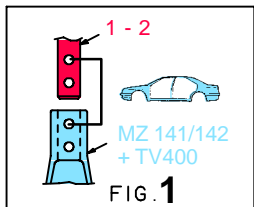
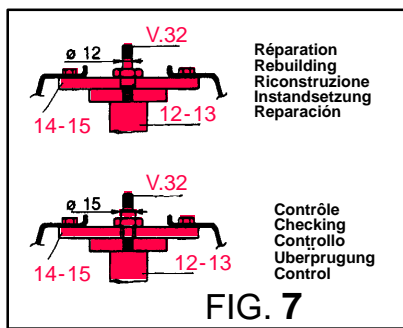
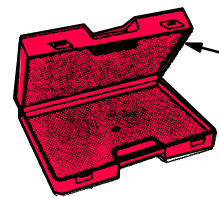
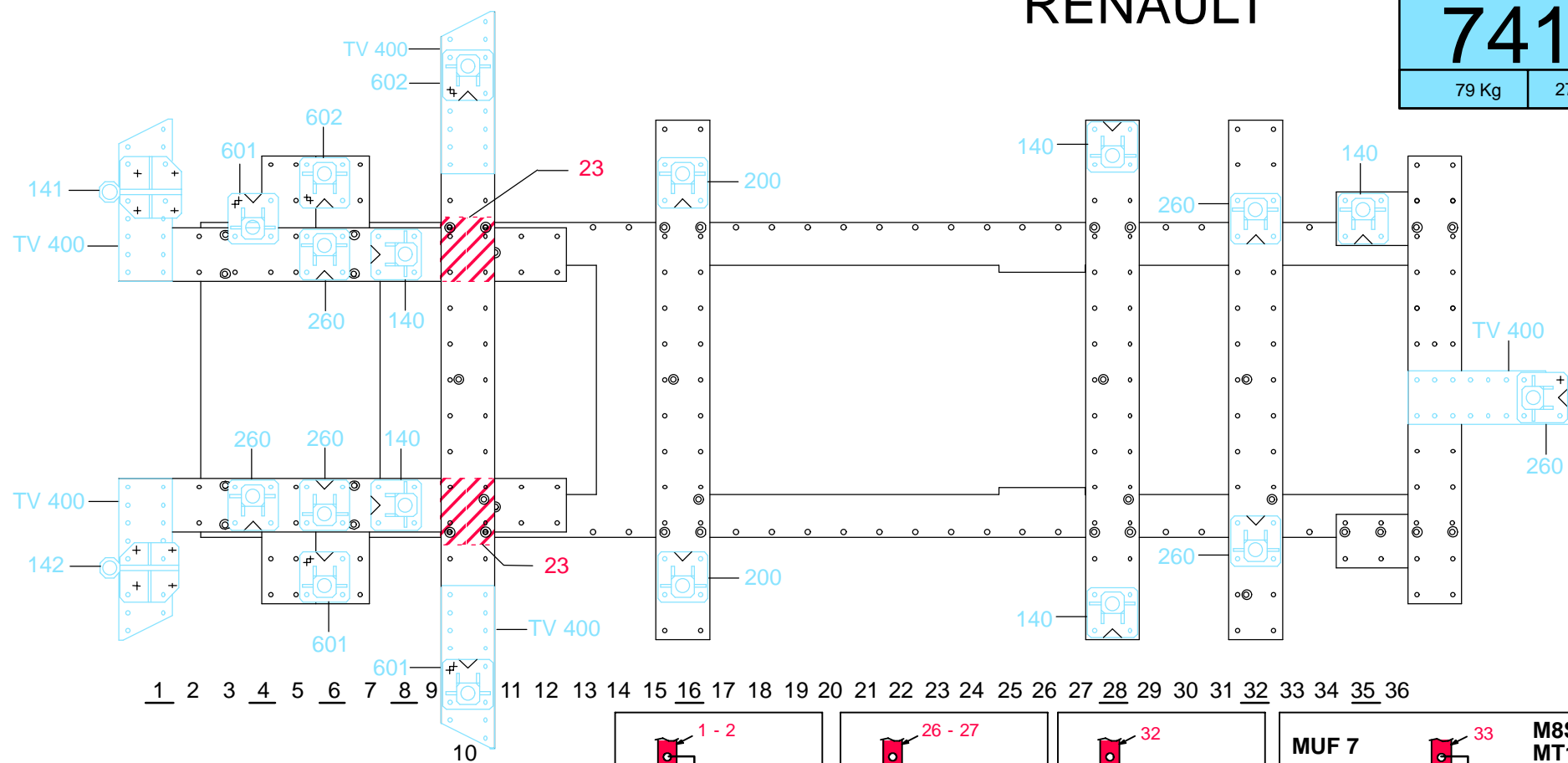

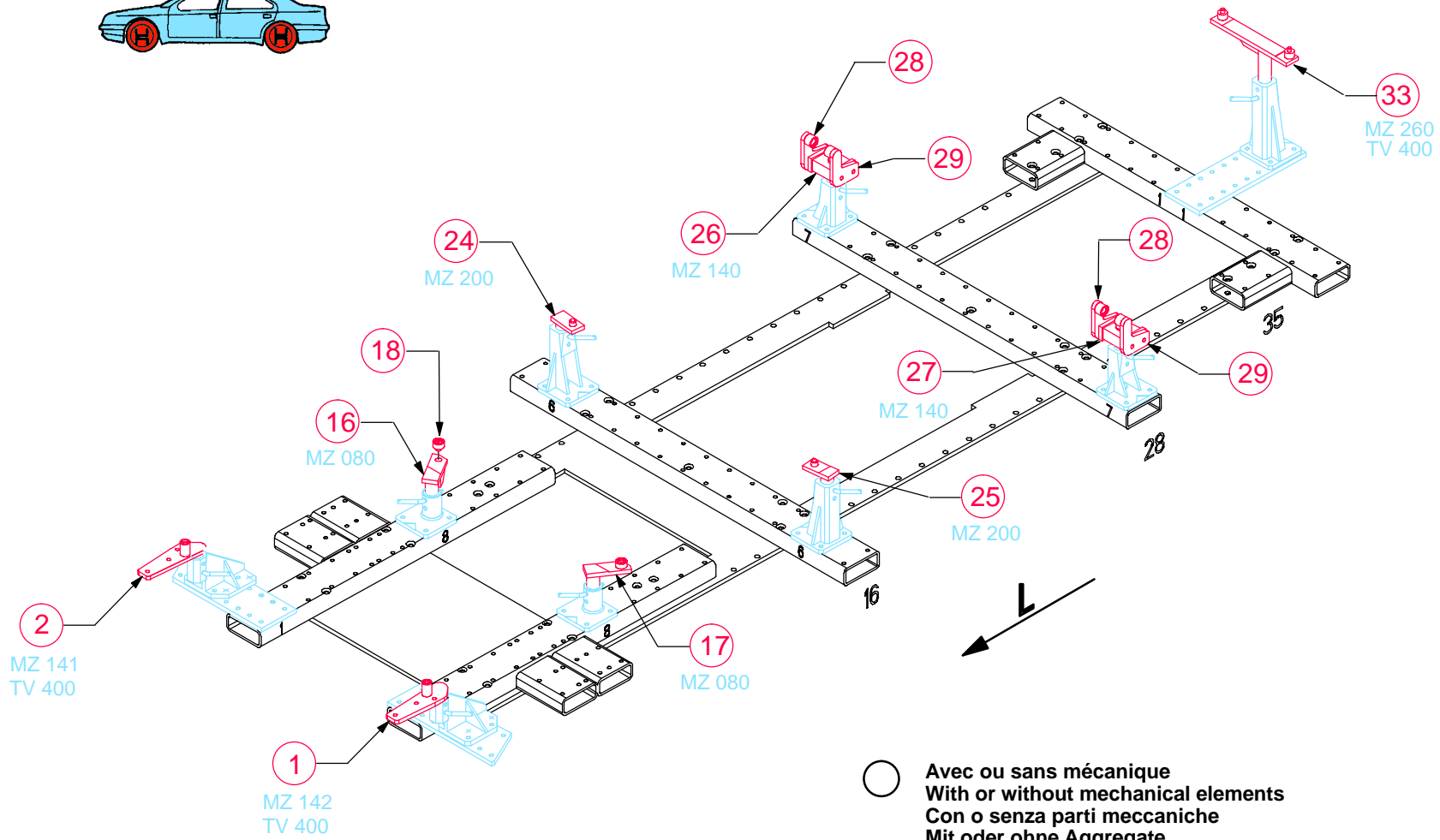
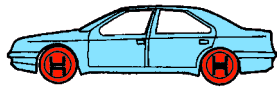

RENAULT

741.300

79 Kg | 27.09.96 | 427-D-24B

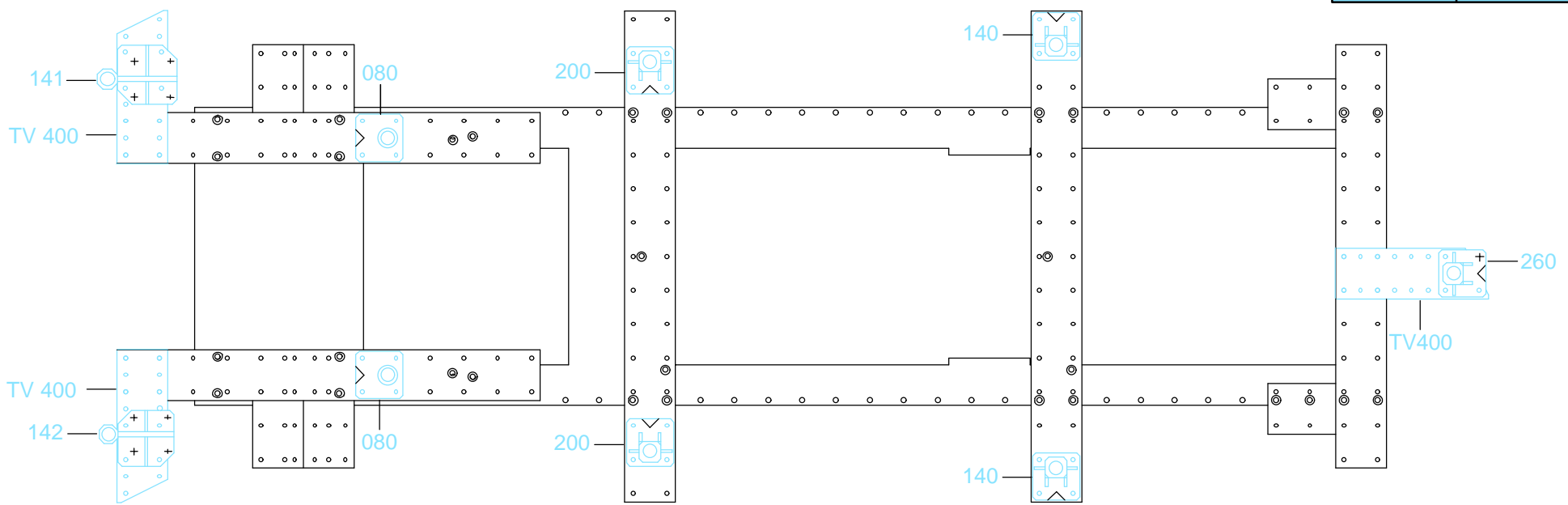

1 2 3 4 5 6 7 8 9 10 11 12 13 14 15 16 17 18 19 20 21 22 23 24 25 26 27 28 29 30 31 32 33 34 35 36

