

Choc avant sur chassis ou chassis plus caisse  
 Front crash on the frame or frame + car-body  
 Frontreparatur am Rahmen oder am kompletten Fahrzeug  
 Urto anterioare sul telaio + scocca  
 Choque delantero sobre chasis o chasis + caja

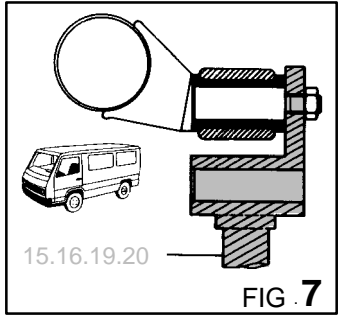
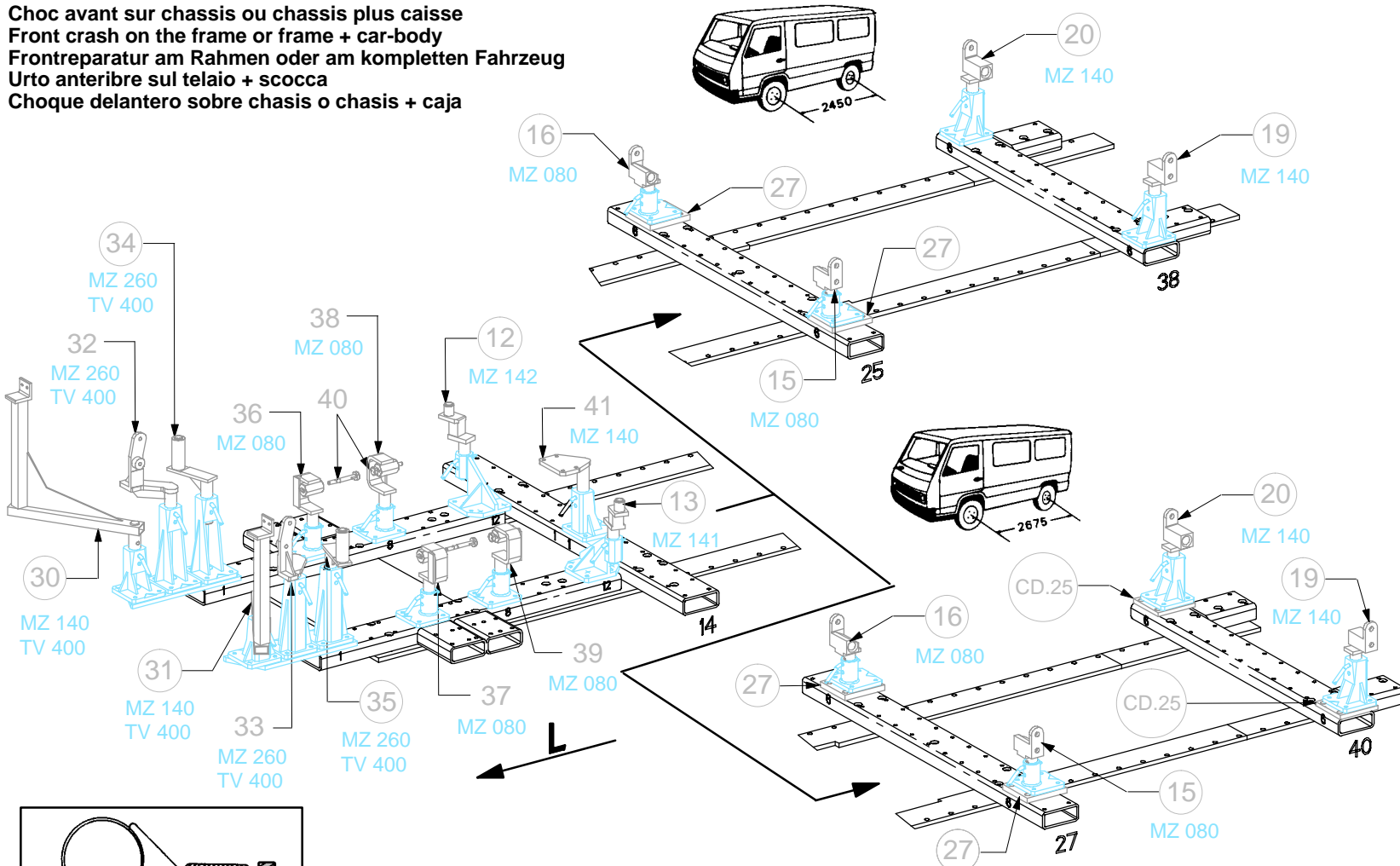

○ Avec ou sans mécanique  
 With or without mechanical elements  
 Con o senza parti meccaniche  
 Mit oder ohne Aggregate  
 Con ó sin mecanica desmontada

## SSANG YONG

REP.	REFERENCE	PDS	NB	MZ
12	728.7012	2,5	1	142
13	728.7013	2,5	1	141
15	728.7015	2,8	1	140/080
16	728.7016	2,8	1	140/080
17	728.7017	2,0	1	200
18	728.7018	2,0	1	200
19	728.7019	1	1	200/140
20	728.7020	1	1	200/140
27	728.7027	3,8	2	
30	728.7030	5,9	1	140
31	728.7031	5,9	1	140
32	728.7032	3,8	1	260
33	728.7033	3,8	1	260
34	728.7034	3,5	1	260
35	728.7035	3,5	1	260
36	728.7036	3,4	1	080
37	728.7037	3,4	1	080
38	728.7038	3,4	1	080
39	728.7039	3,4	1	080
40	728.7040	0,2	4	
41	728.7041	3,4	1	140
42	728.7042	2,9	1	140
43	728.7043	2,4	1	140
	CD.25	2,6	2	

M 6x25	4
M 10.125x30	2
M 10.125x50	2
M 10x30	4
M 12x25	16
M 12.150x40	2
M 12.150x80	2
M 12.150x120	2
M 12.150x150	2
CHc 12x25 TB	16
M 12	4
M 12	4

# 728.300

95 Kg    25.03.96    456-D-1A

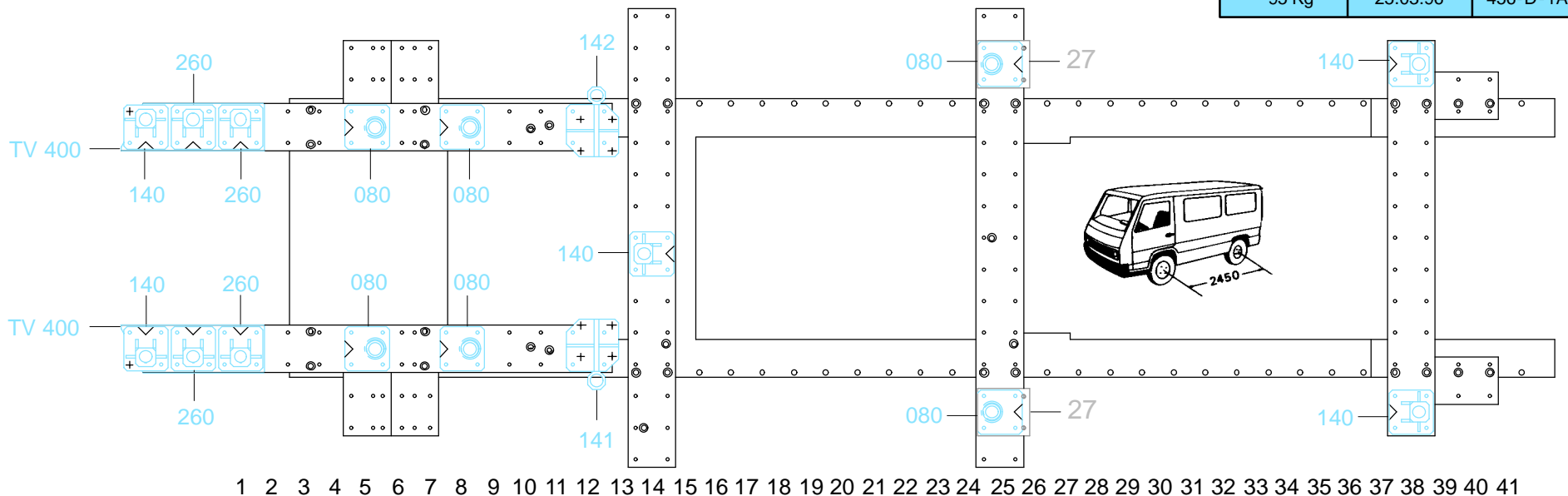

1 2 3 4 5 6 7 8 9 10 11 12 13 14 15 16 17 18 19 20 21 22 23 24 25 26 27 28 29 30 31 32 33 34 35 36 37 38 39 40 41

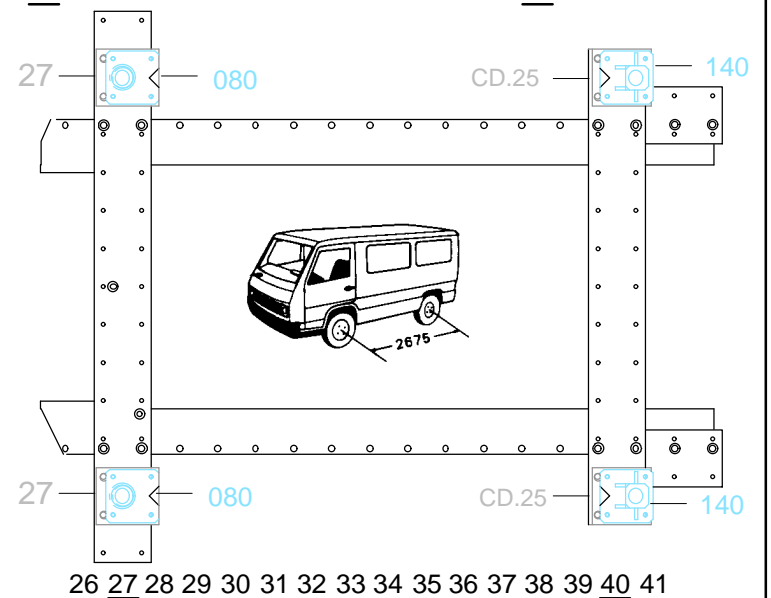
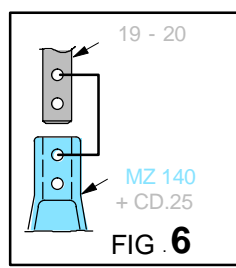
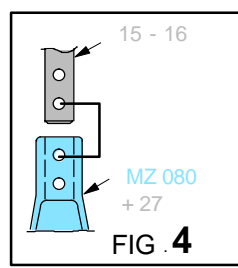
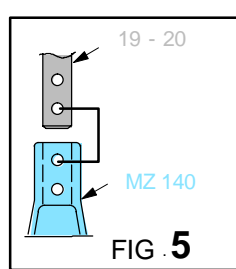
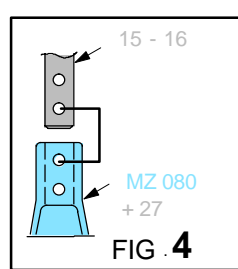
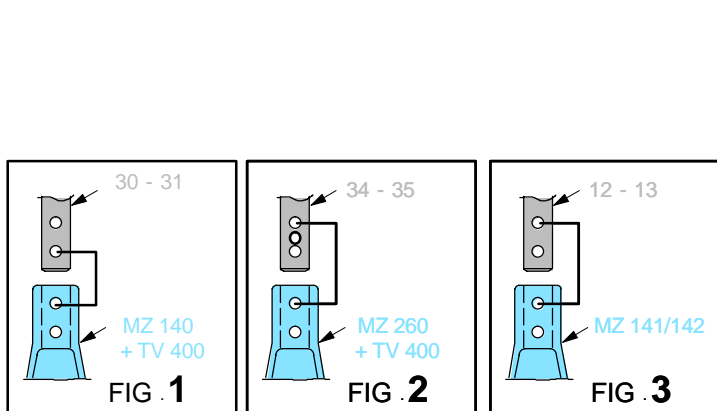



Léger choc arrière avec mécanique arrière  
 Light rear crash with rear mechanical units in place  
 Leichter Heckshaden bei eingebauten Aggregaten (hinten)  
 Urto posteriore leggero con meccanica posteriore  
 Legero choque trasero con mecanica trasera montada

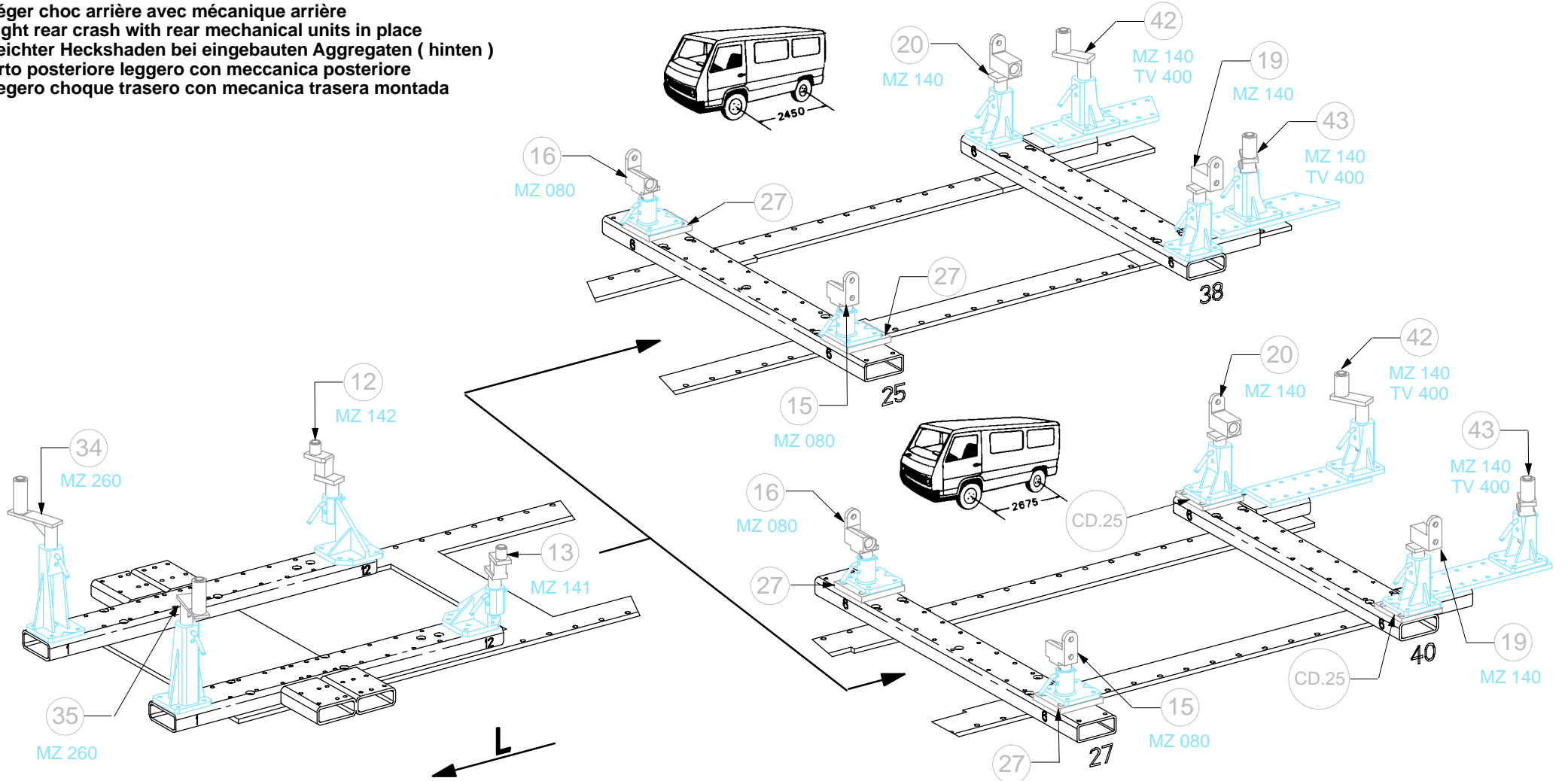

○ Avec ou sans mécanique  
 With or without mechanical elements  
 Con o senza parti meccaniche  
 Mit oder ohne Aggregate  
 Con ó sin mecanica desmontada

**SSANG YONG**

**728.300**

95 Kg	25.03.96	456-D-1C
-------	----------	----------

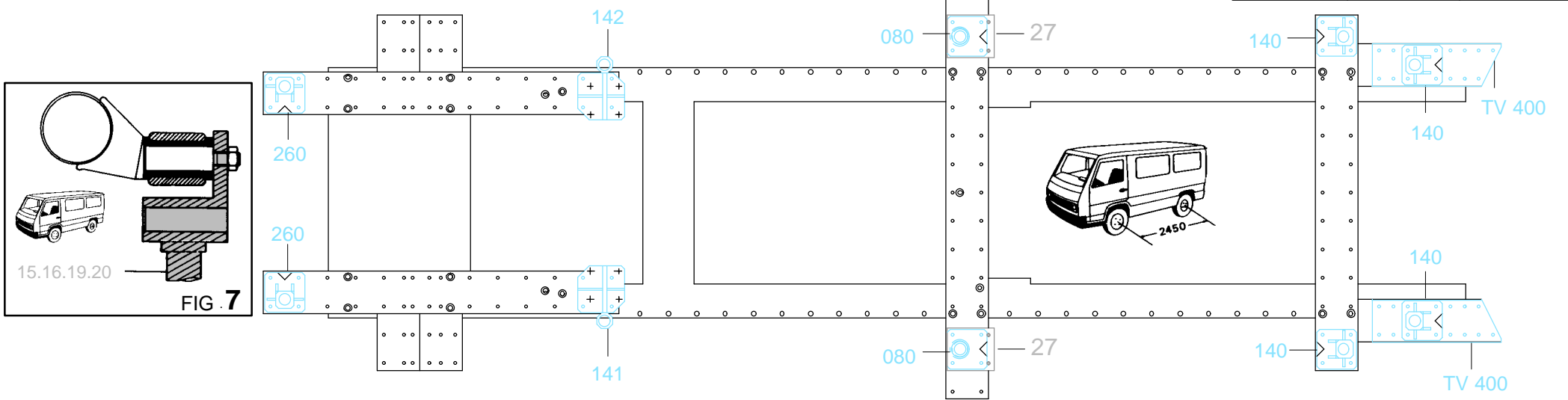

1 2 3 4 5 6 7 8 9 10 11 12 13 14 15 16 17 18 19 20 21 22 23 24 25 26 27 28 29 30 31 32 33 34 35 36 37 38 39 40 41

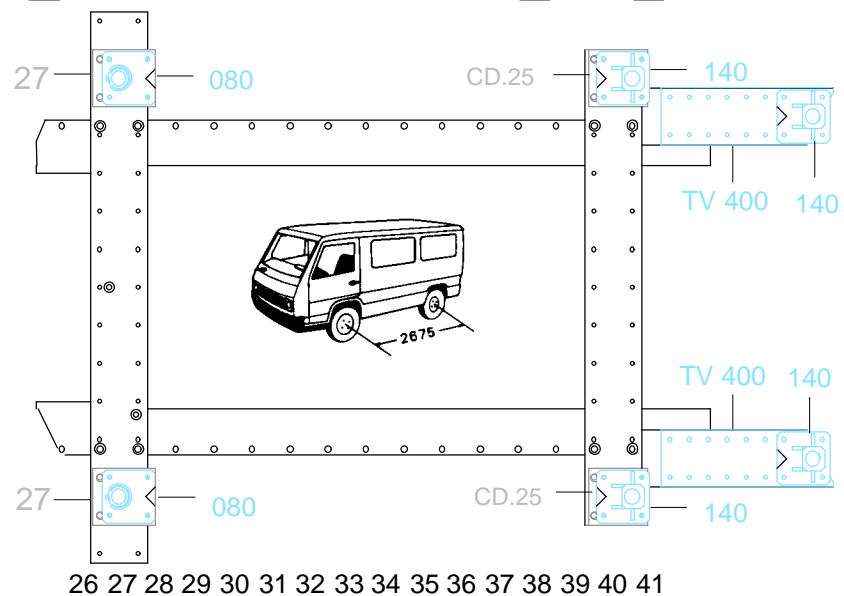
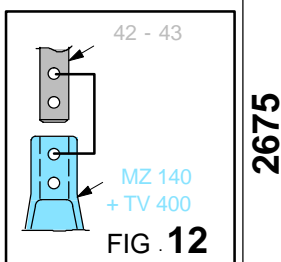
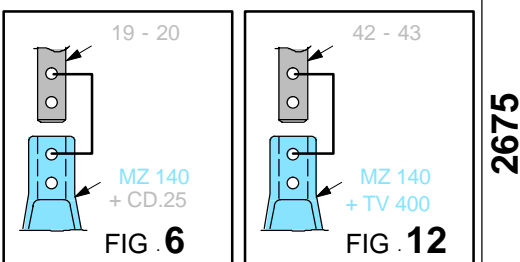
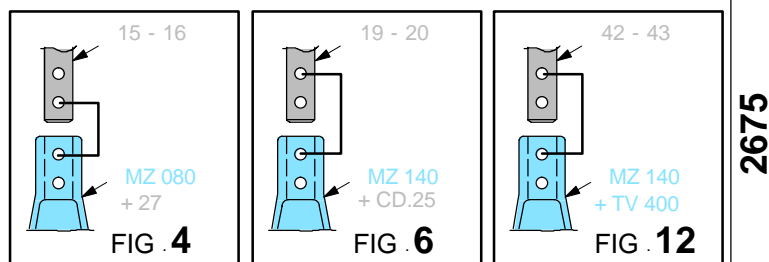
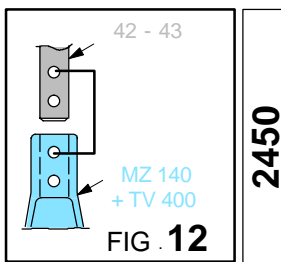
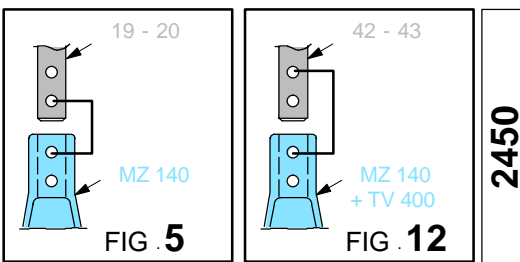
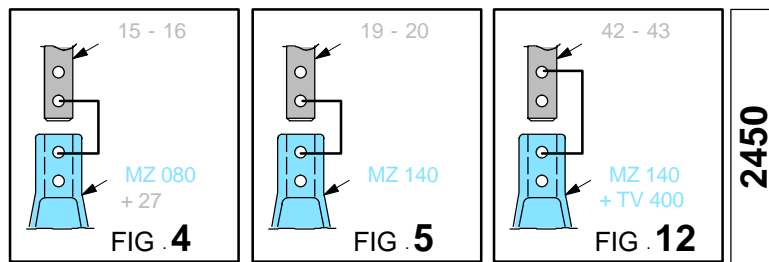
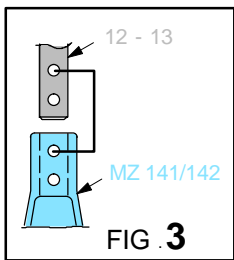
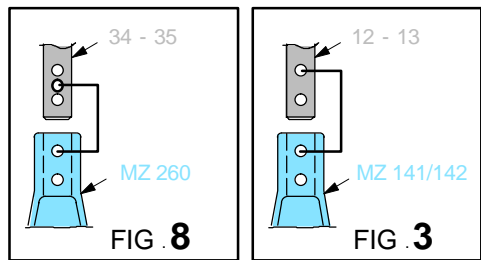

26 27 28 29 30 31 32 33 34 35 36 37 38 39 40 41



Choc sur caisse  
Crash on the car-body  
Reparatur an Karosserie  
Urto sulla scocca  
Choque sobre caja

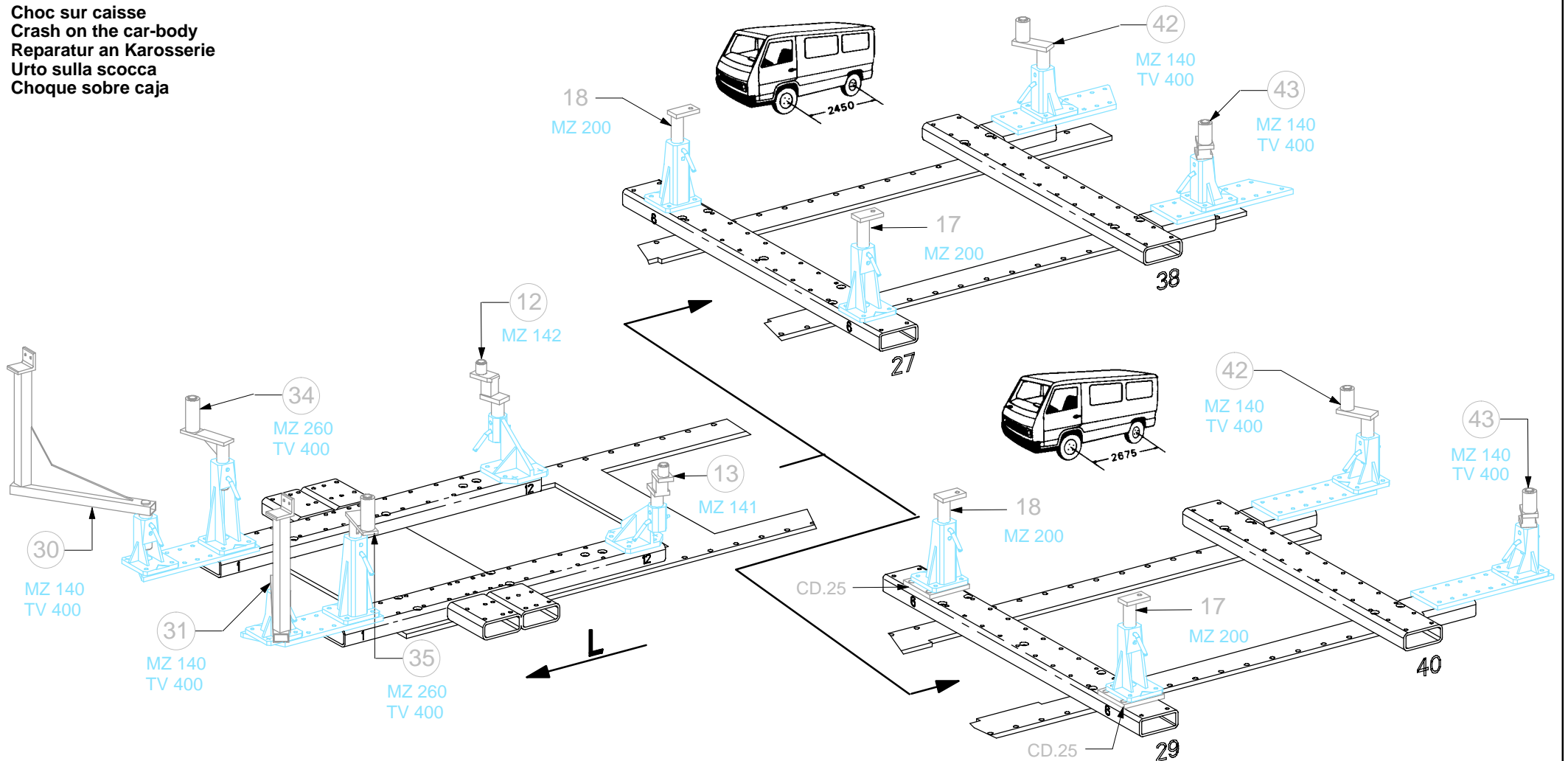

○ Avec ou sans mécanique  
With or without mechanical elements  
Con o senza parti meccaniche  
Mit oder ohne Aggregate  
Con ó sin mecanica desmontada

**SSANG YONG**

**728.300**

95 Kg    25.03.96    456-D-1D

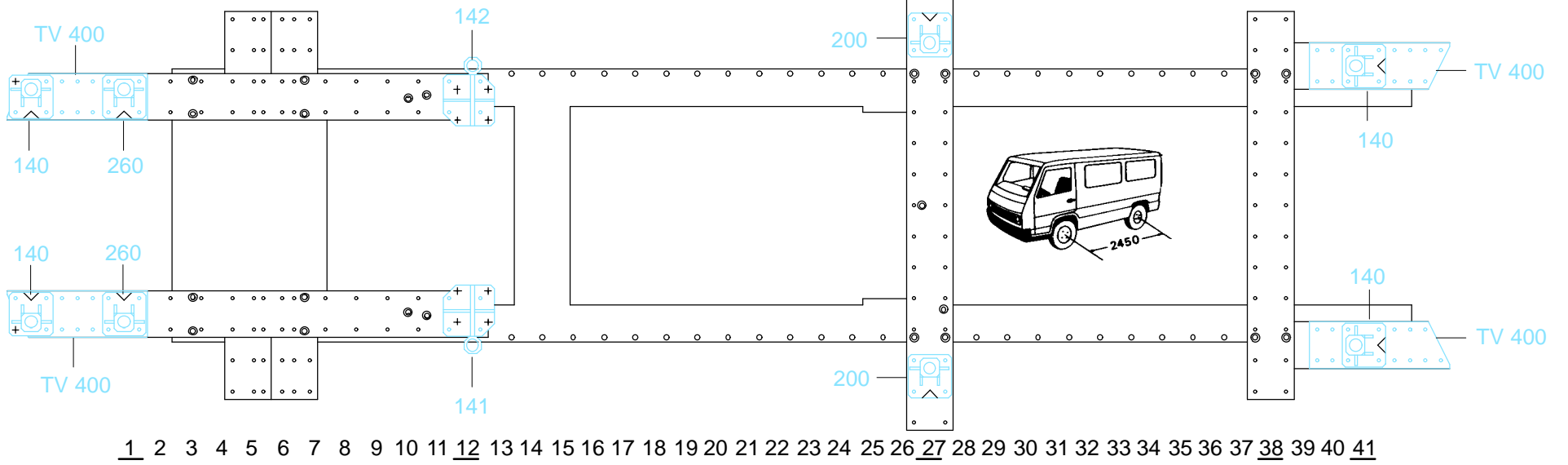

1 2 3 4 5 6 7 8 9 10 11 12 13 14 15 16 17 18 19 20 21 22 23 24 25 26 27 28 29 30 31 32 33 34 35 36 37 38 39 40 41

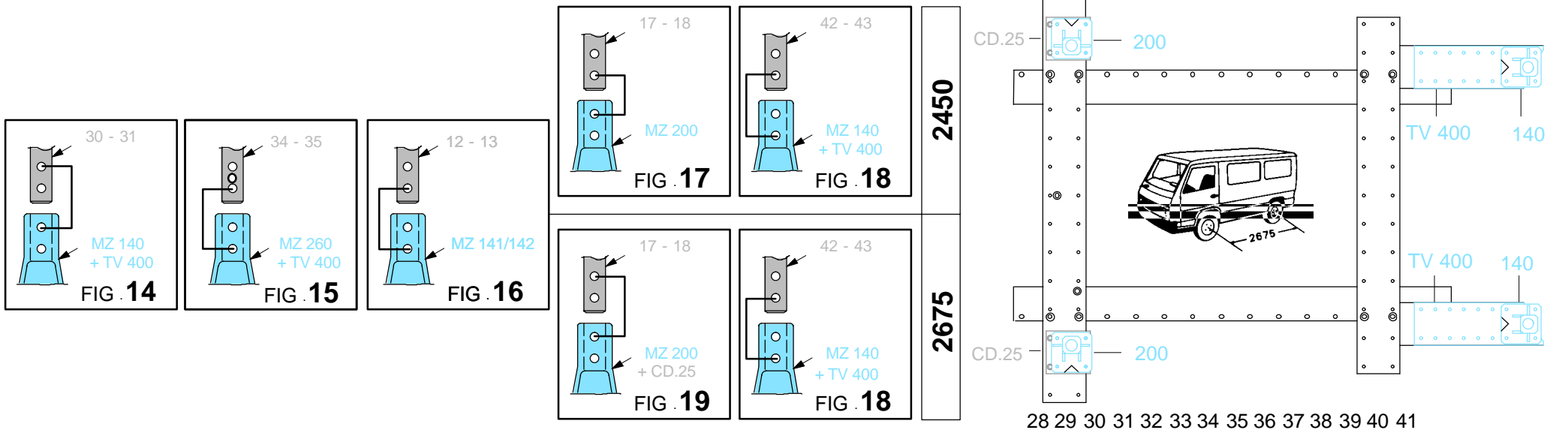

Léger choc arrière avec mécanique arrière  
 Light rear crash with rear mechanical units in place  
 Leichter Heckshaden bei eingebauten Aggregaten (hinten)  
 Urto posteriore leggero con meccanica posteriore  
 Legero choque trasero con mecanica trasera montada

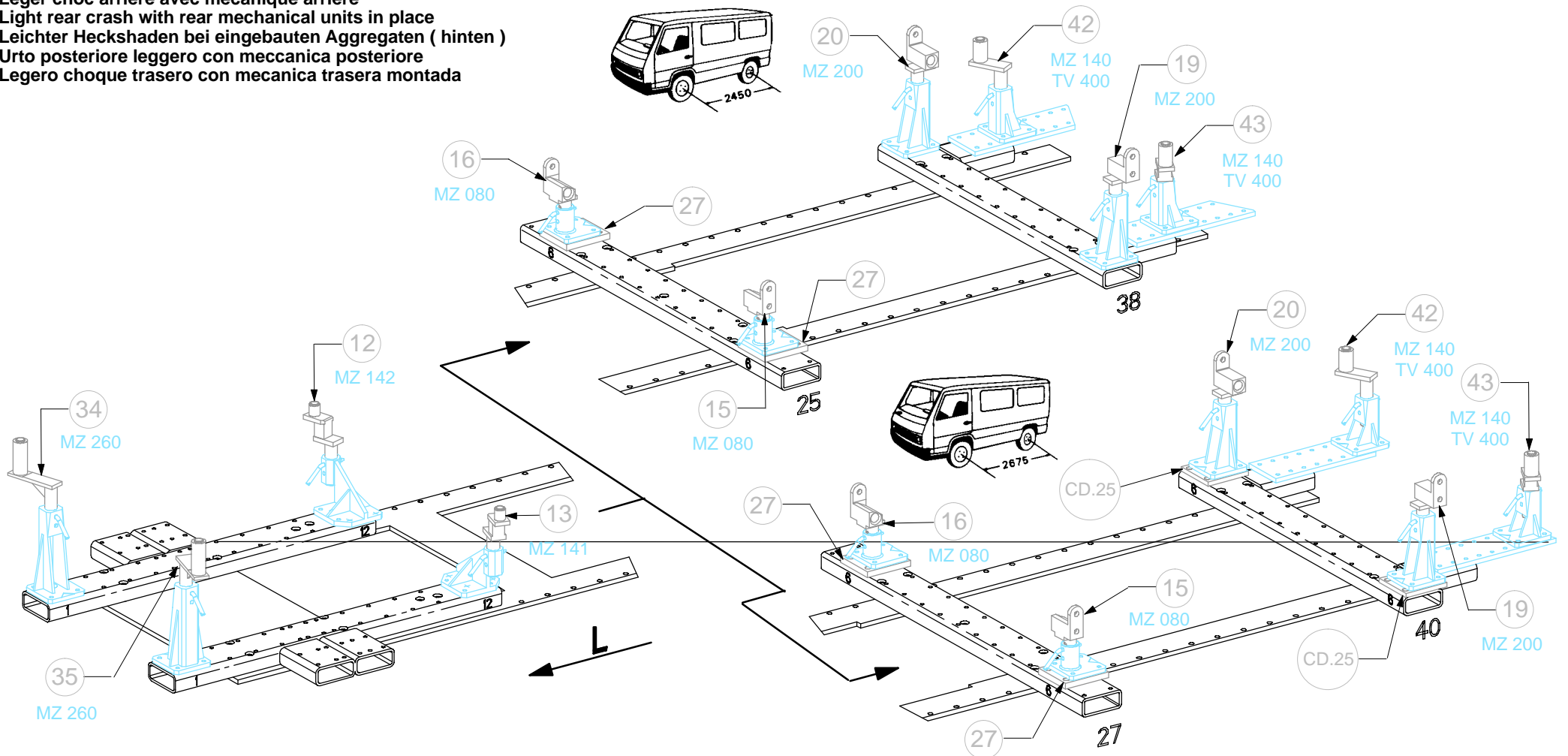

○ Avec ou sans mécanique  
 With or without mechanical elements  
 Con o senza parti meccaniche  
 Mit oder ohne Aggregate  
 Con ó sin mecanica desmontada

**SSANG YONG**

**728.300**

95 Kg    25.03.96    456-D-1E

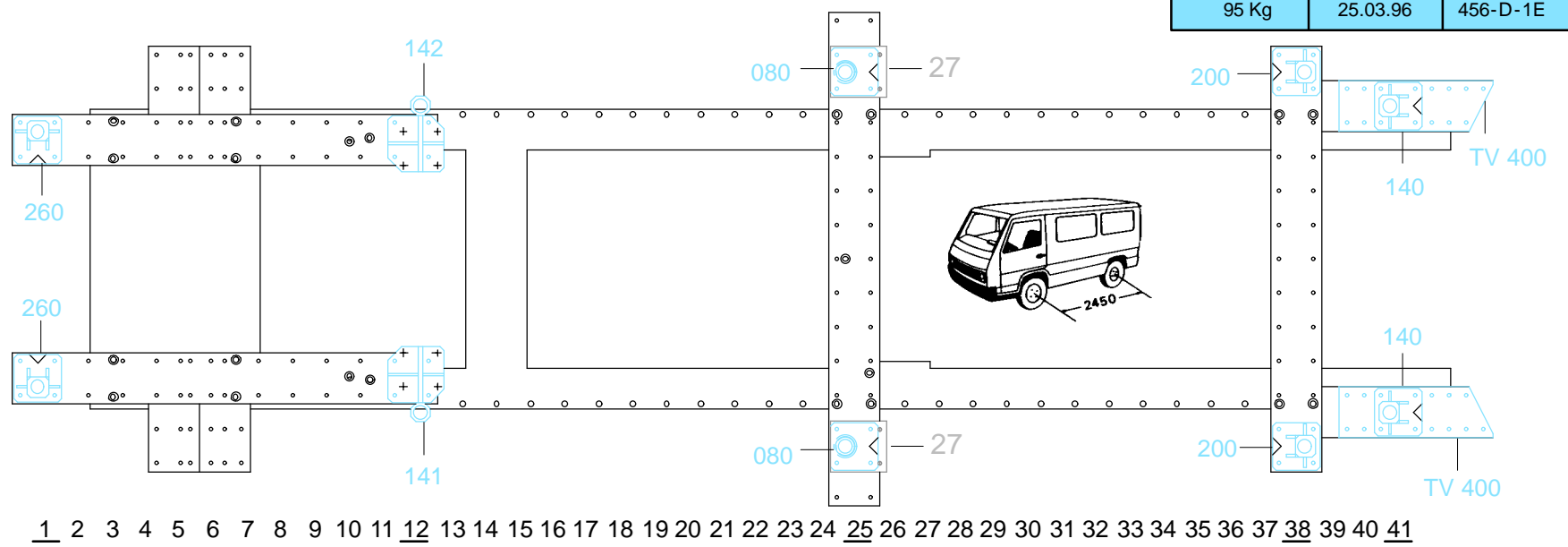
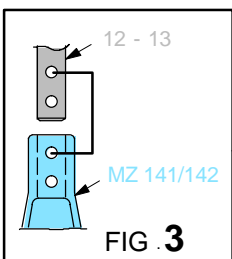
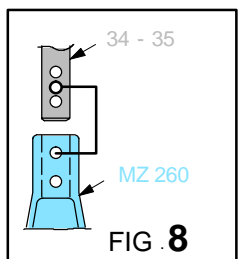
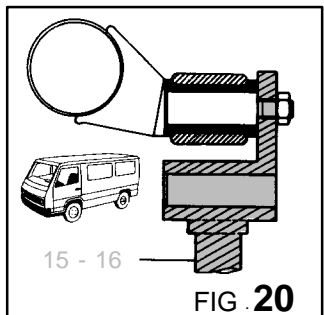
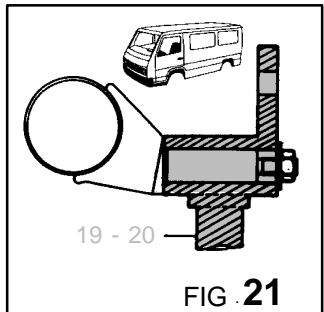

1 2 3 4 5 6 7 8 9 10 11 12 13 14 15 16 17 18 19 20 21 22 23 24 25 26 27 28 29 30 31 32 33 34 35 36 37 38 39 40 41

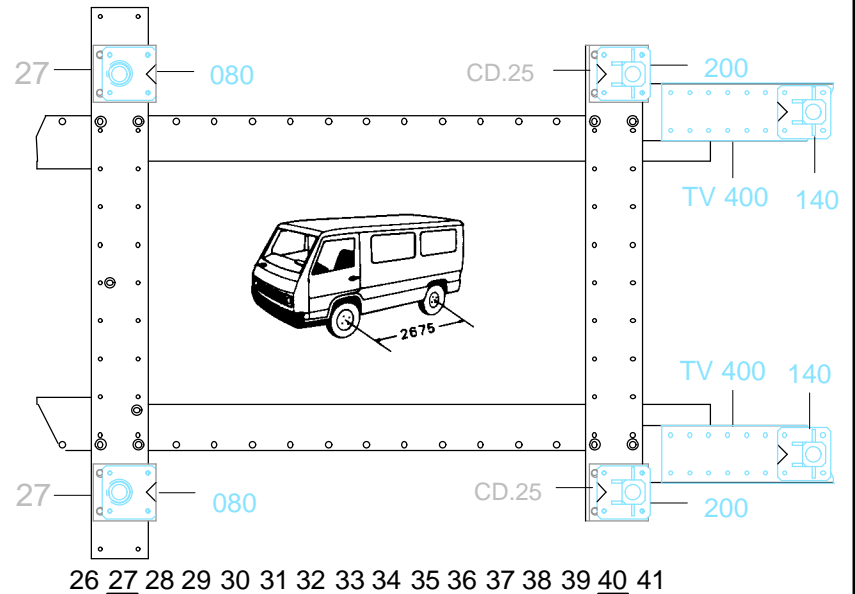
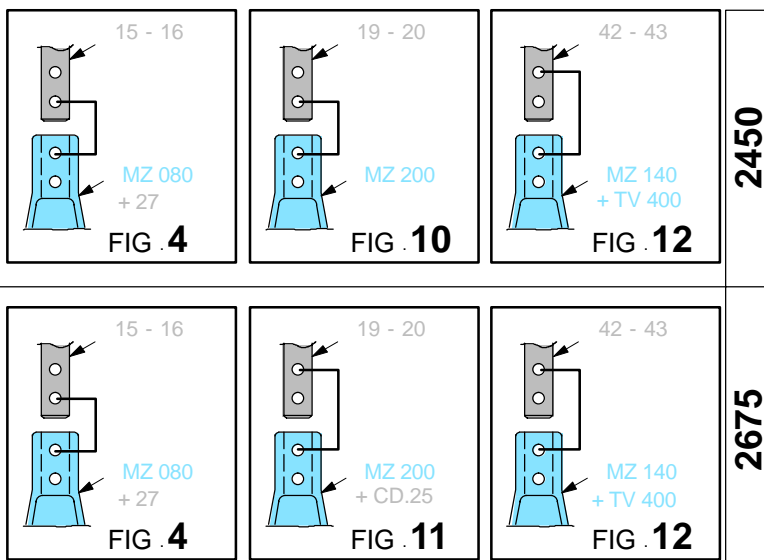

26 27 28 29 30 31 32 33 34 35 36 37 38 39 40 41