

○ Avec ou sans mécanique
 With or without mechanical elements
 Con o senza parti meccaniche
 Mit oder ohne Aggregate
 Con ó sin mecanica desmontada

MITSUBISHI

REP.	REFERENCE	PDS	NB	MZ
1	724.7001	1,7	1	140
2	724.7002	1,7	1	140
3	724.7003	1,9	1	141
4	724.7004	1,9	1	142
5	724.7005	2,4	1	601
6	724.7006	2,4	1	602
7	724.7007	1,5	1	260/080
8	724.7008	1,5	1	260/080
9	724.7009	0,8	2	
10	724.7010	0,7	2	
11	724.7011	2,0	1	140/080
12	724.7012	2,0	1	140/080
13	724.7013	1,2	1	080
14	724.7014	1,2	1	080
15	724.7015	1,4	1	140
16	724.7016	1,4	1	140
17	724.7017	1,8	1	200
18	724.7018	1,8	1	200
19	724.7019	2,1	1	080
20	724.7020	2,1	1	080
21	724.7021	1,1	1	
22	724.7022	1,1	1	
23	724.7023	3,7	1	260
24	724.7024	3,7	1	260
25	724.7025	0,4	2	
26	724.7026	1,4	1	200
27	724.7027	1,4	1	200
28	724.7028	0,9	2	
	E.16	0,1	2	
	B.81	0,1	8	

M 10.125x30	4
M 12x20	2
M 12x30	8
M 12.125x70	2
M 12.125x80	2
M 12.125x110	4
M 12.125x120	2

724.300

52 Kg 11.07.96 421-D-21A

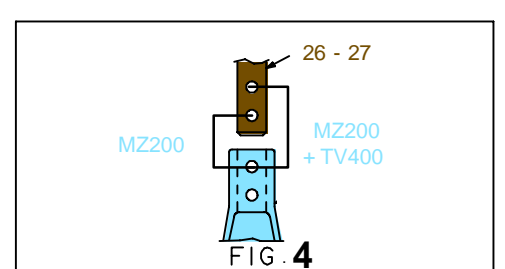
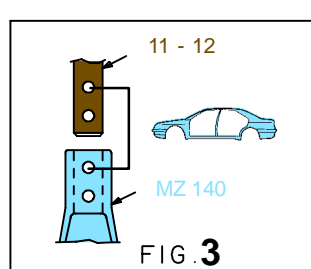
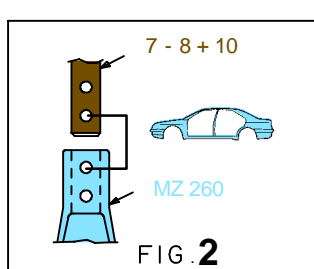
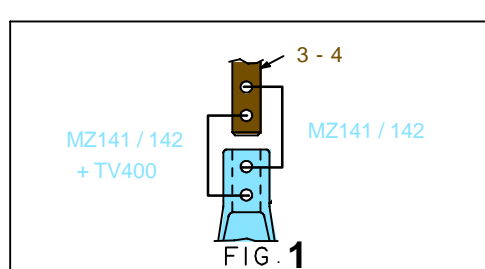
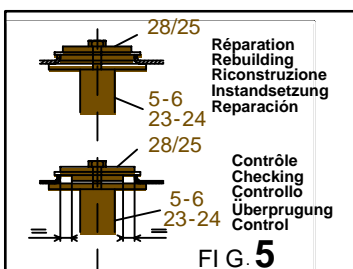
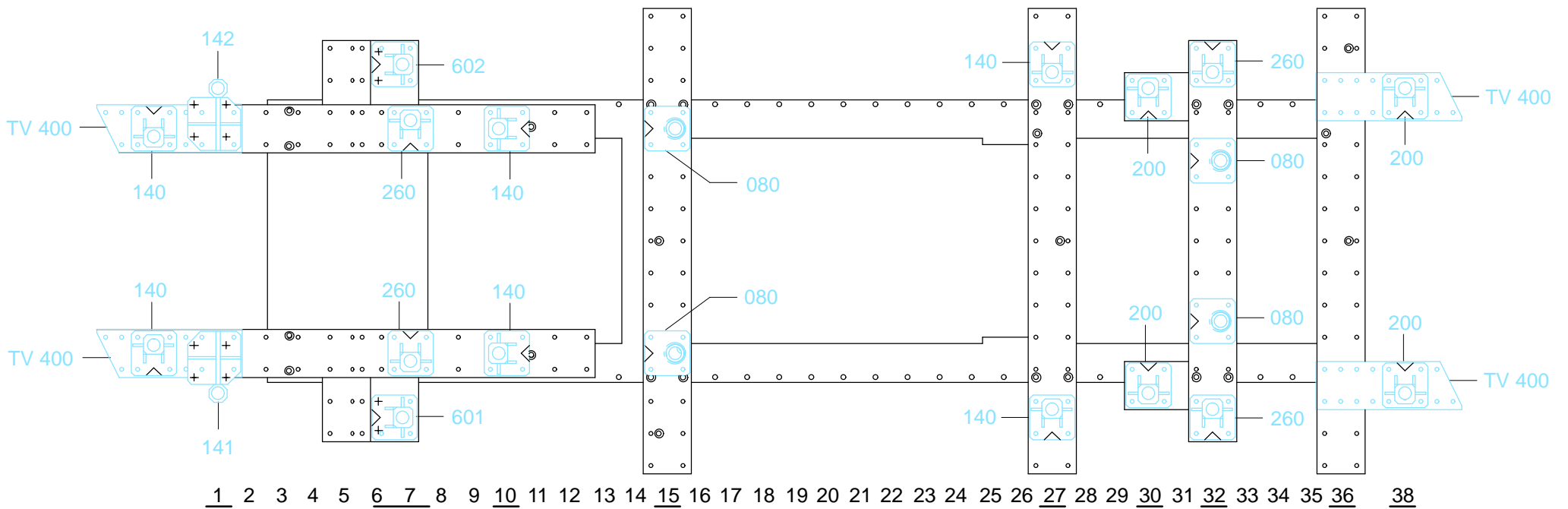

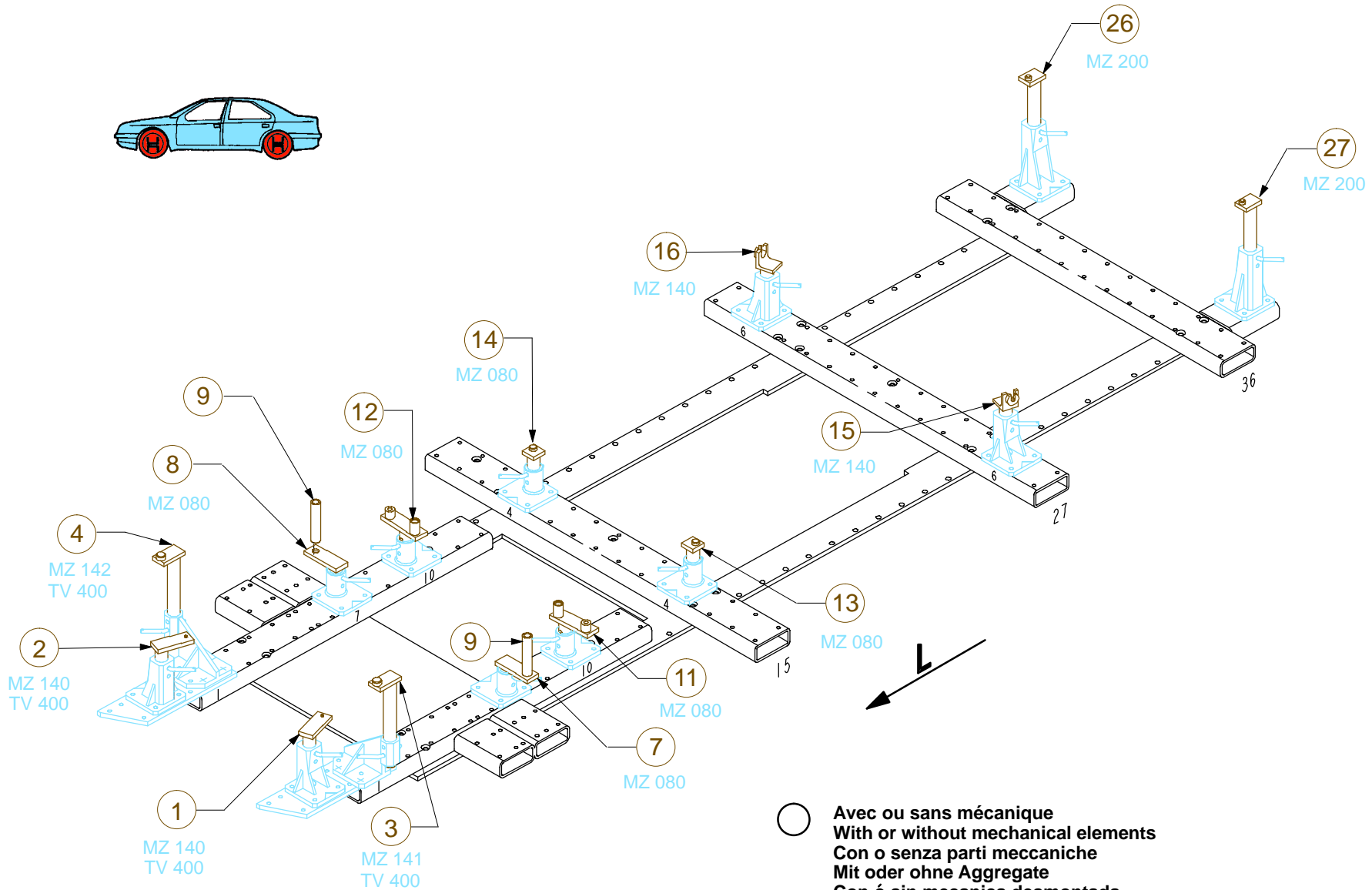
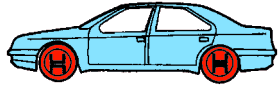

○ Avec ou sans mécanique
 With or without mechanical elements
 Con o senza parti meccaniche
 Mit oder ohne Aggregate
 Con ó sin mecanica desmontada

MITSUBISHI

724.300

52 Kg | 11.07.96 | 421-D-21B

