

REP.	MOD.
5	VOLVO Boite manuel Manual gear box
32	VOLVO Boite Automatique Automatic gear box

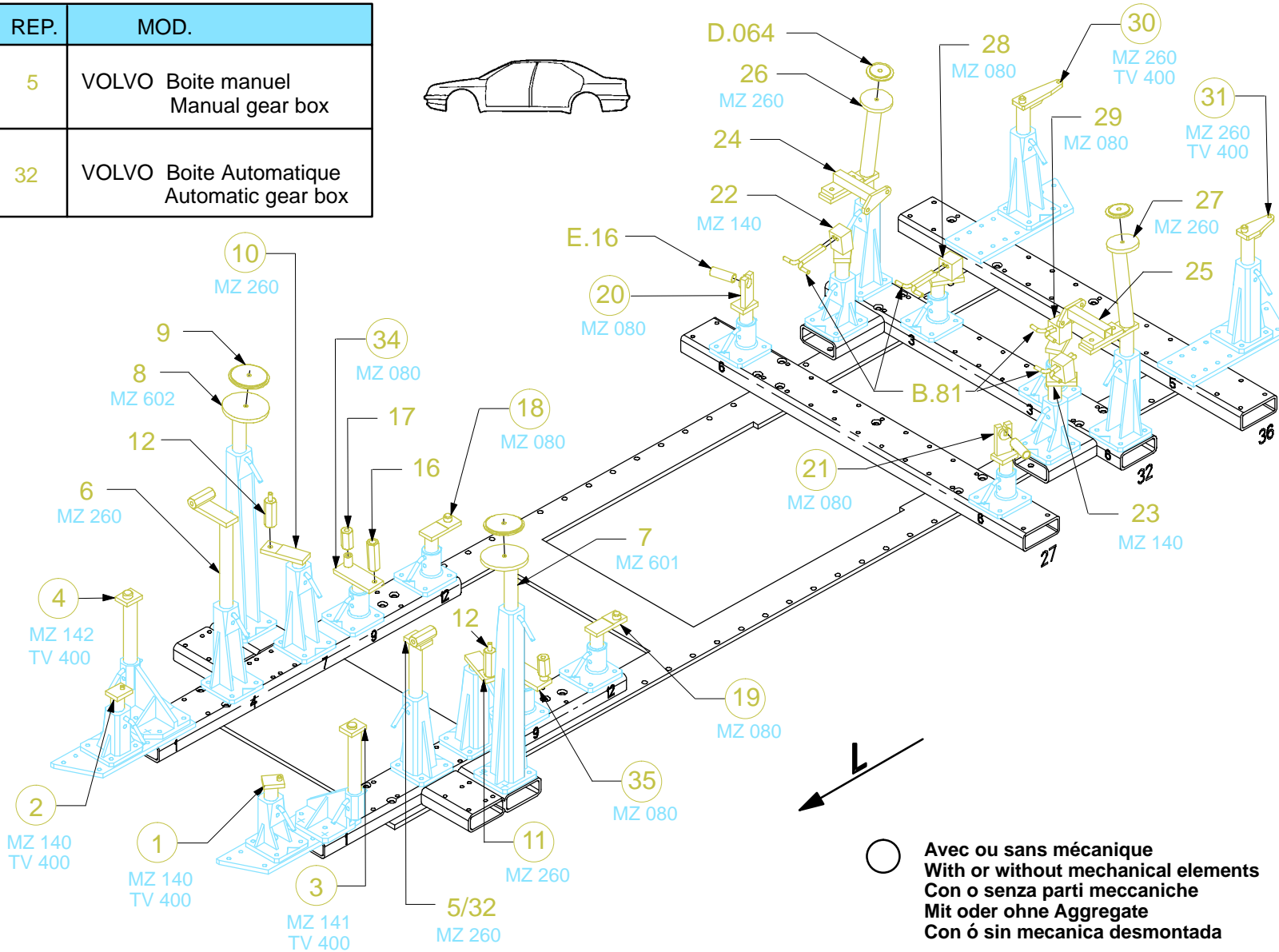

○ Avec ou sans mécanique
With or without mechanical elements
Con o senza parti meccaniche
Mit oder ohne Aggregate
Con ó sin mecanica desmontada

VOLVO

REP.	REFERENCE	PDS	NB	MZ
1	718.7001	1,5	1	140
2	718.7002	1,5	1	140
3	718.7003	1,7	1	141
4	718.7004	1,7	1	142
5	718.7005	2,0	1	260
6	718.7006	2,8	1	260
7	718.7007	2,4	1	601
8	718.7008	2,4	1	602
9	718.7009	0,9	2	
10	718.7010	1,6	1	260/080
11	718.7011	1,6	1	260/080
12	718.7012	0,6	2	
13	718.7013	0,5	2	
16	718.7016	0,4	2	
17	718.7017	0,3	2	
18	718.7018	1,8	1	080
19	718.7019	1,8	1	080
20	718.7020	2,0	1	080
21	718.7021	2,0	1	080
22	718.7022	2,8	1	140
23	718.7023	2,8	1	140
24	718.7024	1,2	1	
25	718.7025	1,2	1	
26	718.7026	4,1	1	260
27	718.7027	4,1	1	260
28	718.7028	2,6	1	080
29	718.7029	2,6	1	080
30	718.7030	2,6	1	260
31	718.7031	2,4	1	260
32	718.7032	2,7	1	260
33	718.7033	0,3	2	
34	718.7034	2,0	1	080
35	718.7035	2,0	1	080
	D.064	0,5	2	
	B.81	0,1	8	
	E.16	0,1	2	

	M 10.125x30	6
	M 12x30	6
	M 12x40	4
	M 12.125x120	2
	M 12.125x140	2
	M 12	4

718.310

69 Kg 02.06.97 439-D-9D

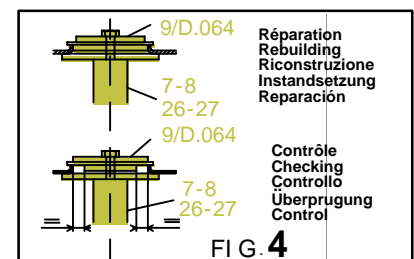
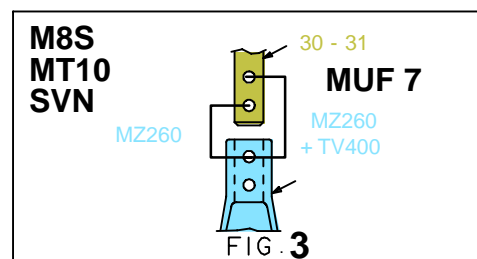
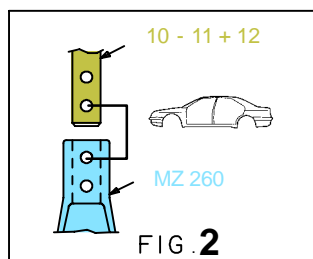
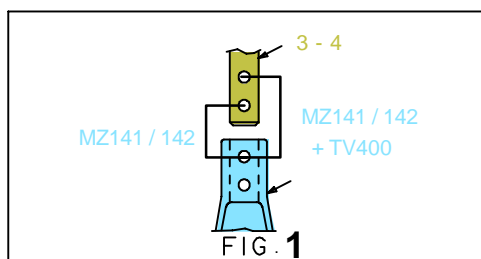
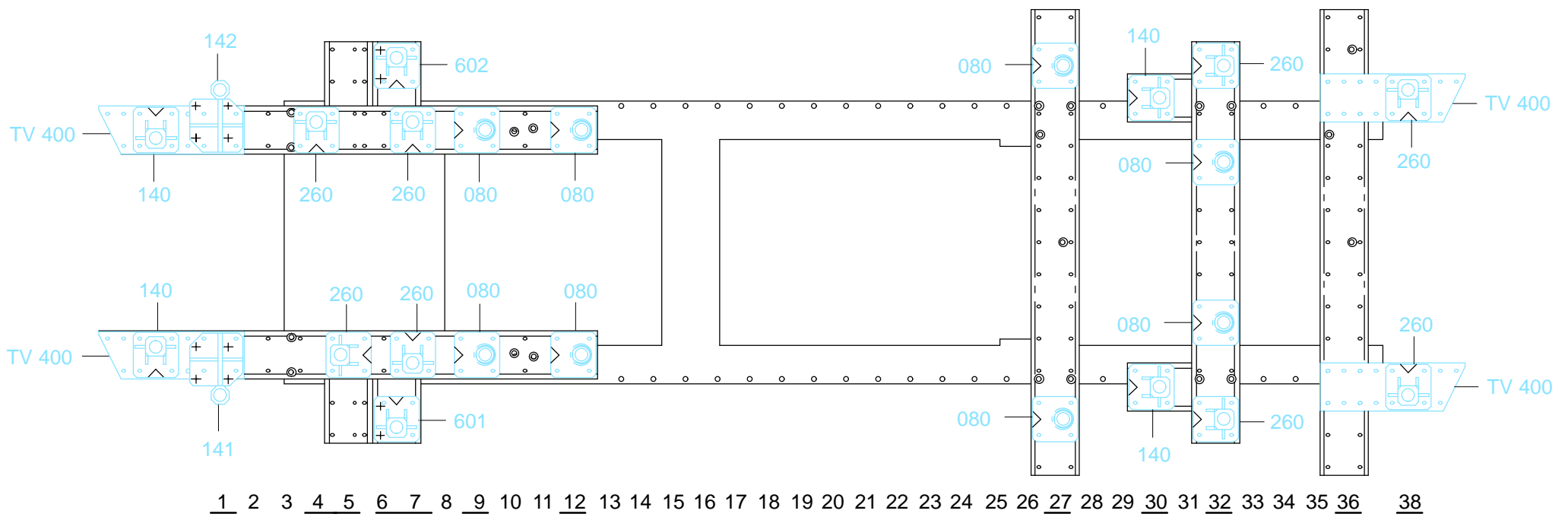

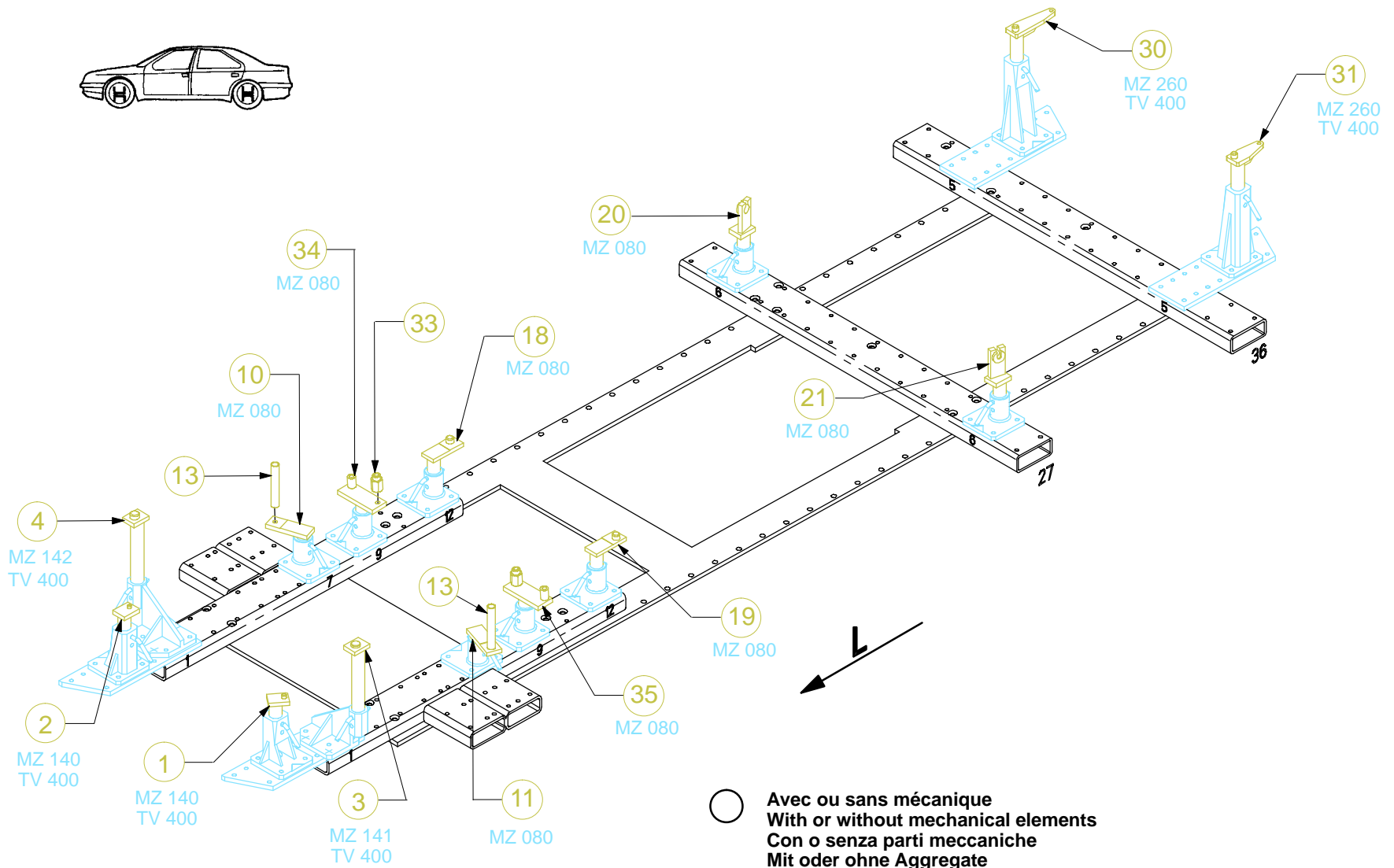
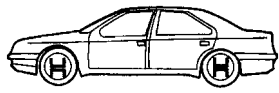

VOLVO

718.310

69 Kg | 02.06.97 | 439-D-9E

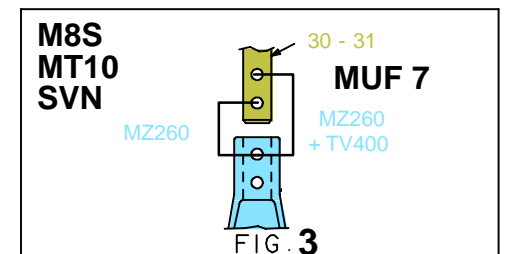
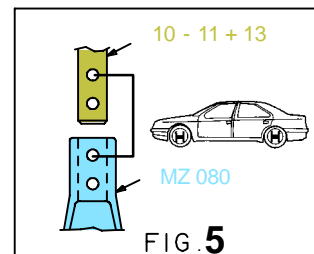
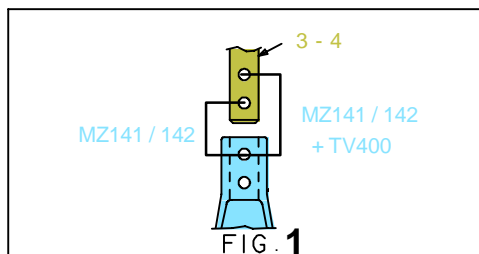
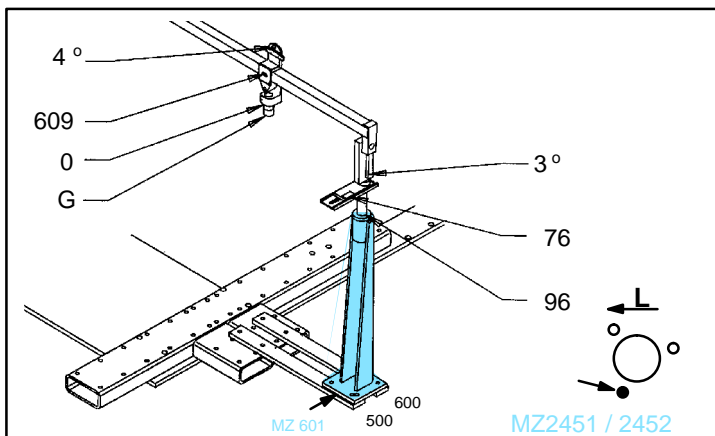
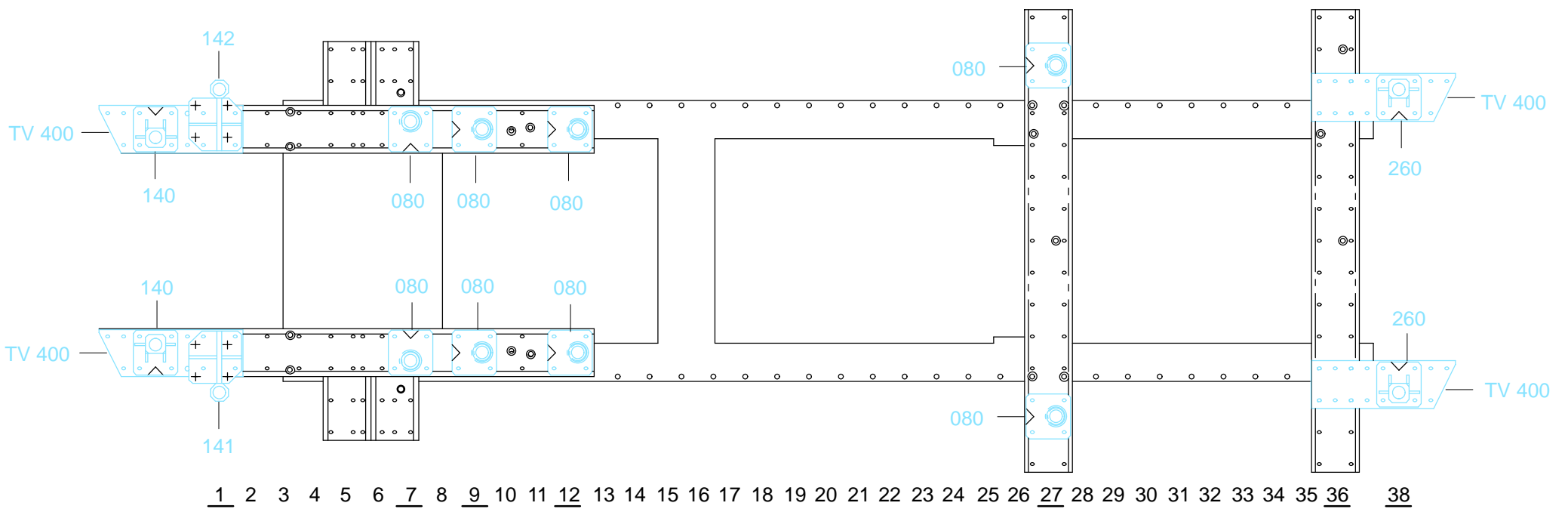

REP.	MOD.
5	CARISMA
32	

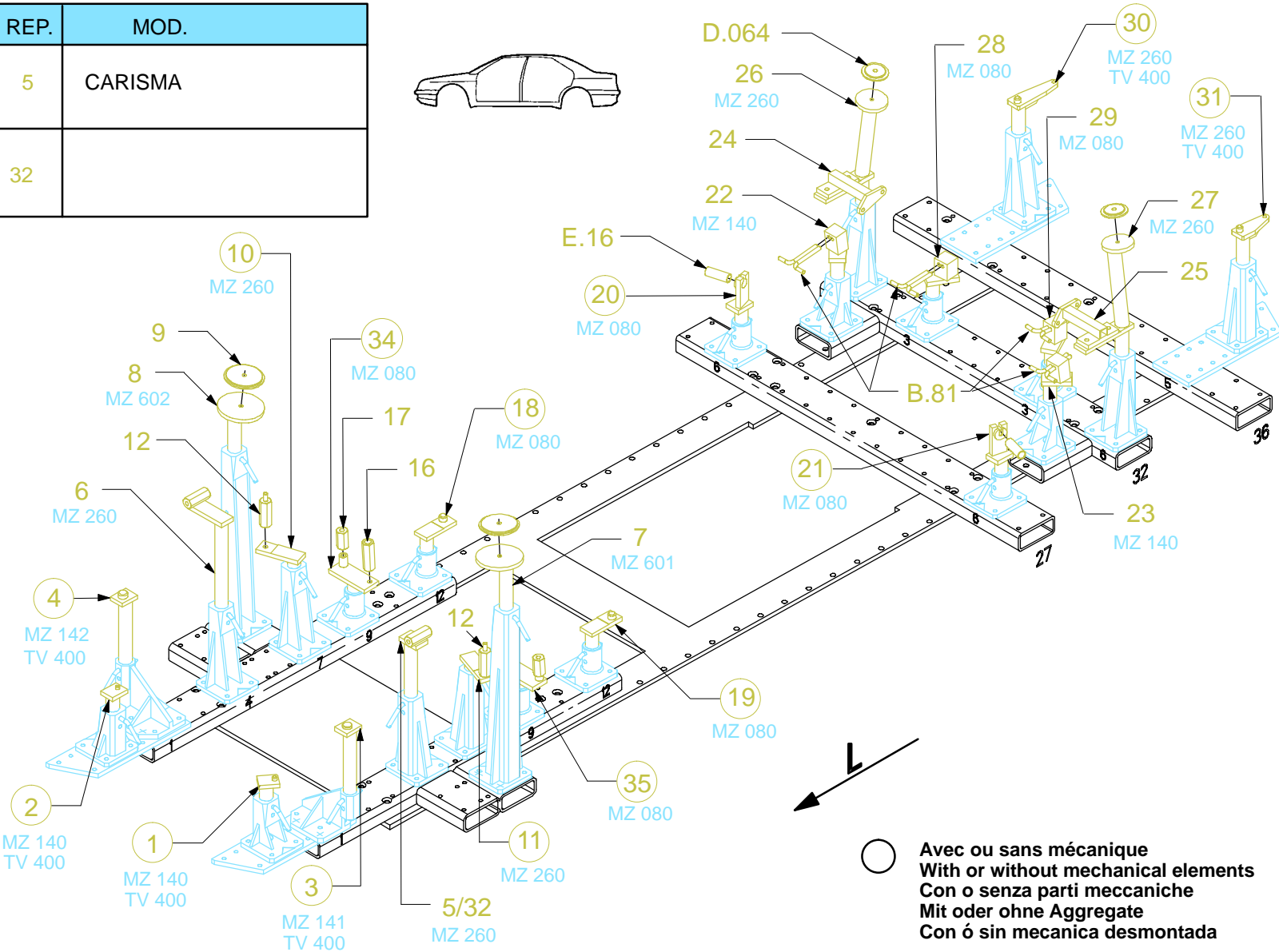

REP.	REFERENCE	PDS	NB	MZ
1	718.7001	1,5	1	140
2	718.7002	1,5	1	140
3	718.7003	1,7	1	141
4	718.7004	1,7	1	142
5	718.7005	2,0	1	260
6	718.7006	2,8	1	260
7	718.7007	2,4	1	601
8	718.7008	2,4	1	602
9	718.7009	0,9	2	
10	718.7010	1,6	1	260/080
11	718.7011	1,6	1	260/080
12	718.7012	0,6	2	
13	718.7013	0,5	2	
16	718.7016	0,4	2	
17	718.7017	0,3	2	
18	718.7018	1,8	1	080
19	718.7019	1,8	1	080
20	718.7020	2,0	1	080
21	718.7021	2,0	1	080
22	718.7022	2,8	1	140
23	718.7023	2,8	1	140
24	718.7024	1,2	1	
25	718.7025	1,2	1	
26	718.7026	4,1	1	260
27	718.7027	4,1	1	260
28	718.7028	2,6	1	080
29	718.7029	2,6	1	080
30	718.7030	2,6	1	260
31	718.7031	2,4	1	260
32	718.7032	2,7	1	260
33	718.7033	0,3	2	
34	718.7034	2,0	1	080
35	718.7035	2,0	1	080
	D.064	0,5	2	
	B.81	0,1	8	
	E.16	0,1	2	

	M 10.125x30	6
	M 12x30	6
	M 12x40	4
	M 12.125x120	2
	M 12.125x140	2
	M 12	4

○ Avec ou sans mécanique
With or without mechanical elements
Con o senza parti meccaniche
Mit oder ohne Aggregate
Con ó sin mecanica desmontada

MITSUBISHI

718.310

69 Kg 02.06.97 421-D-20C

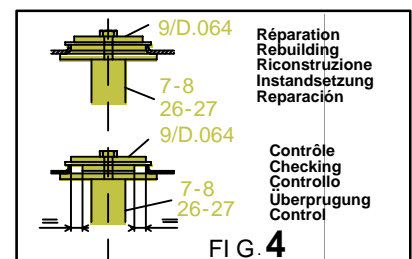
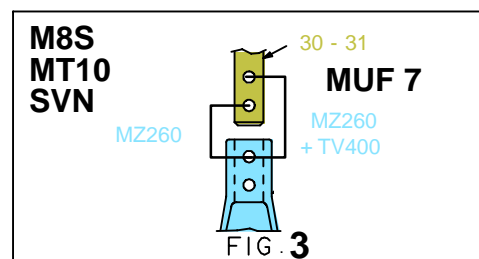
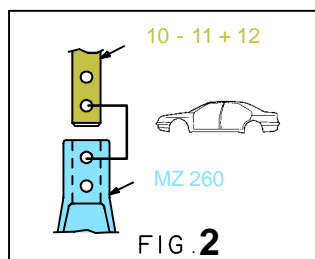
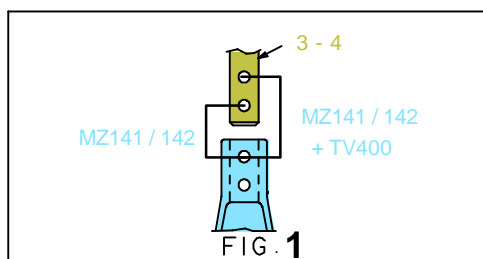
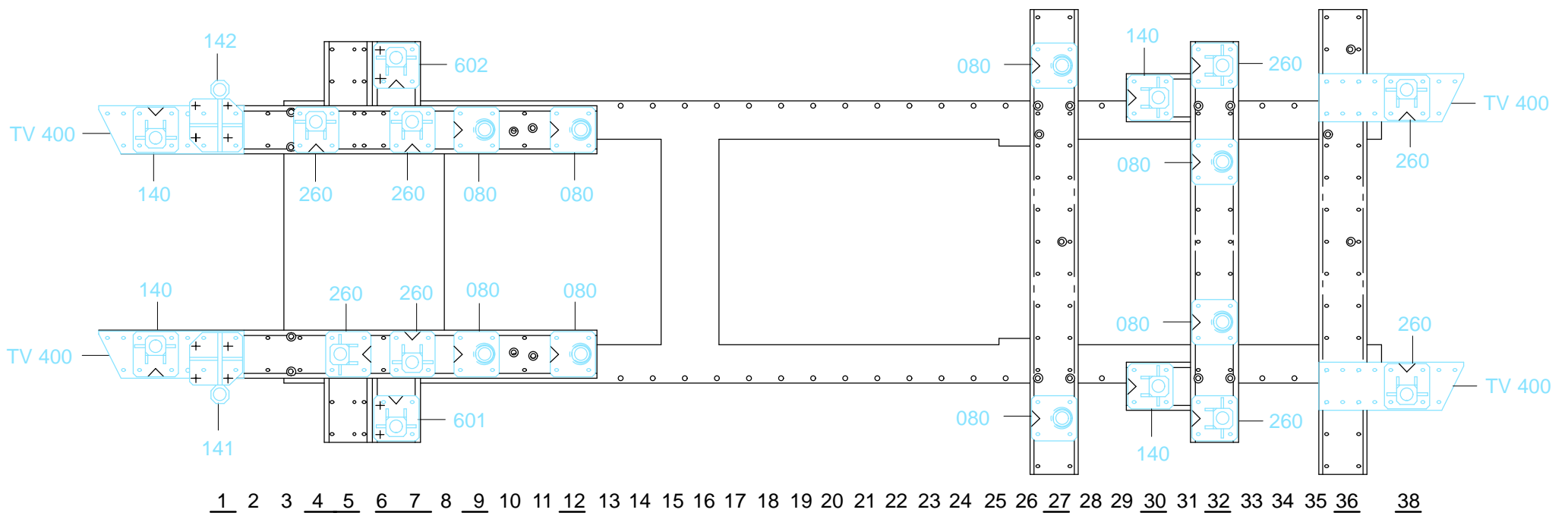

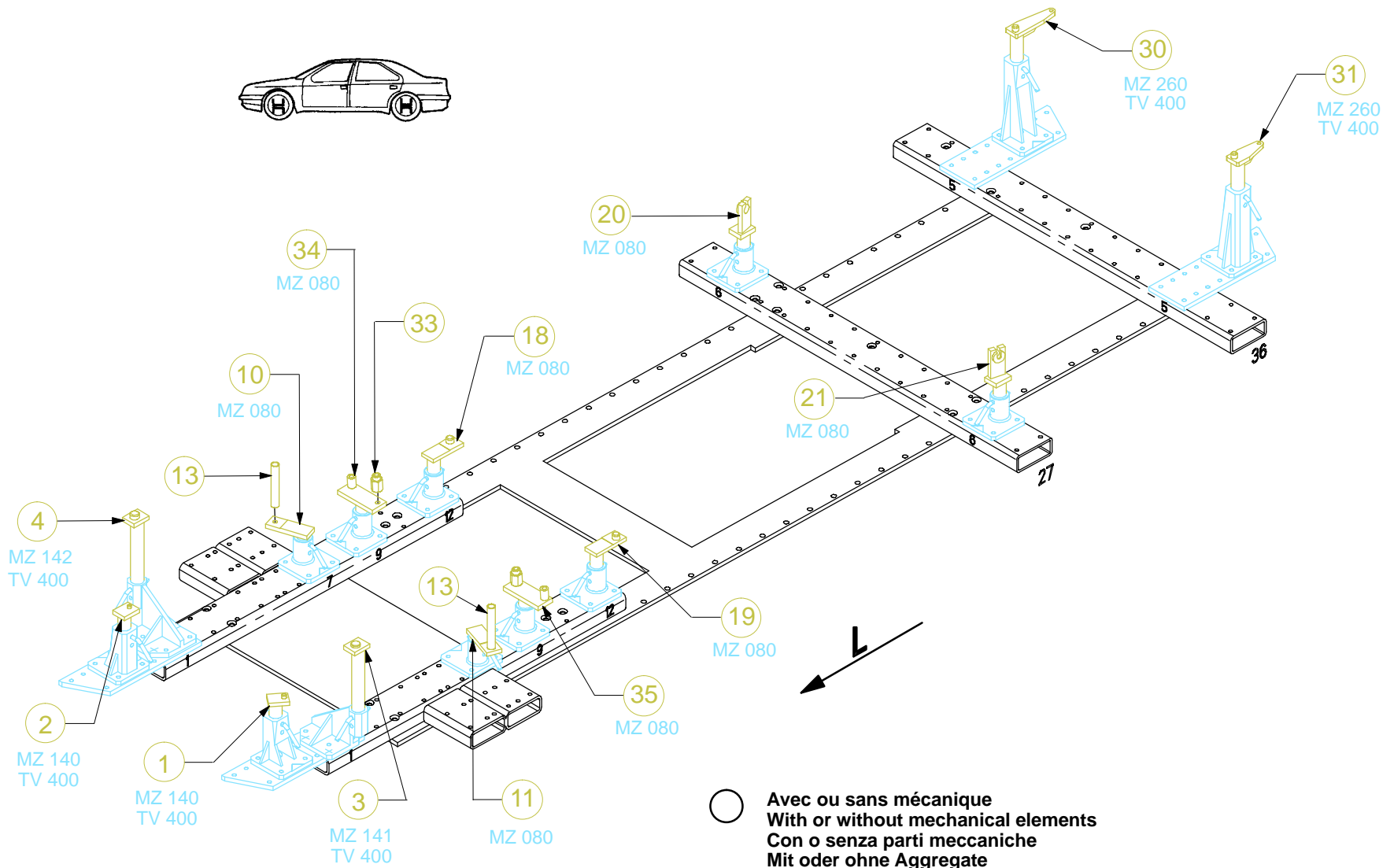

MITSUBISHI

718.310

69 Kg | 02.06.97 | 421-D-20D

