

XX Avec ou sans mécanique
 With or without mechanical elements
 Con o senza parti meccaniche
 Mit oder ohne Aggregate
 Con ó sin mecánica desmontada

7171.300

MERCEDES BENZ

97 Kg	01.12.2003	420-D-31B
7171.300-RVA3-1		01

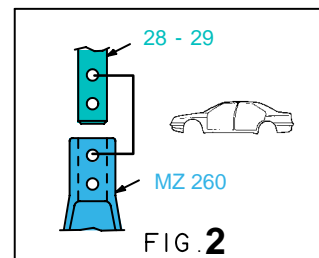
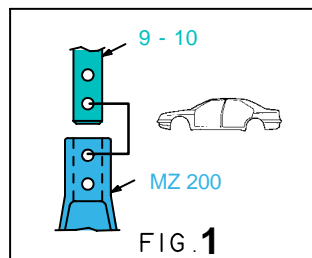
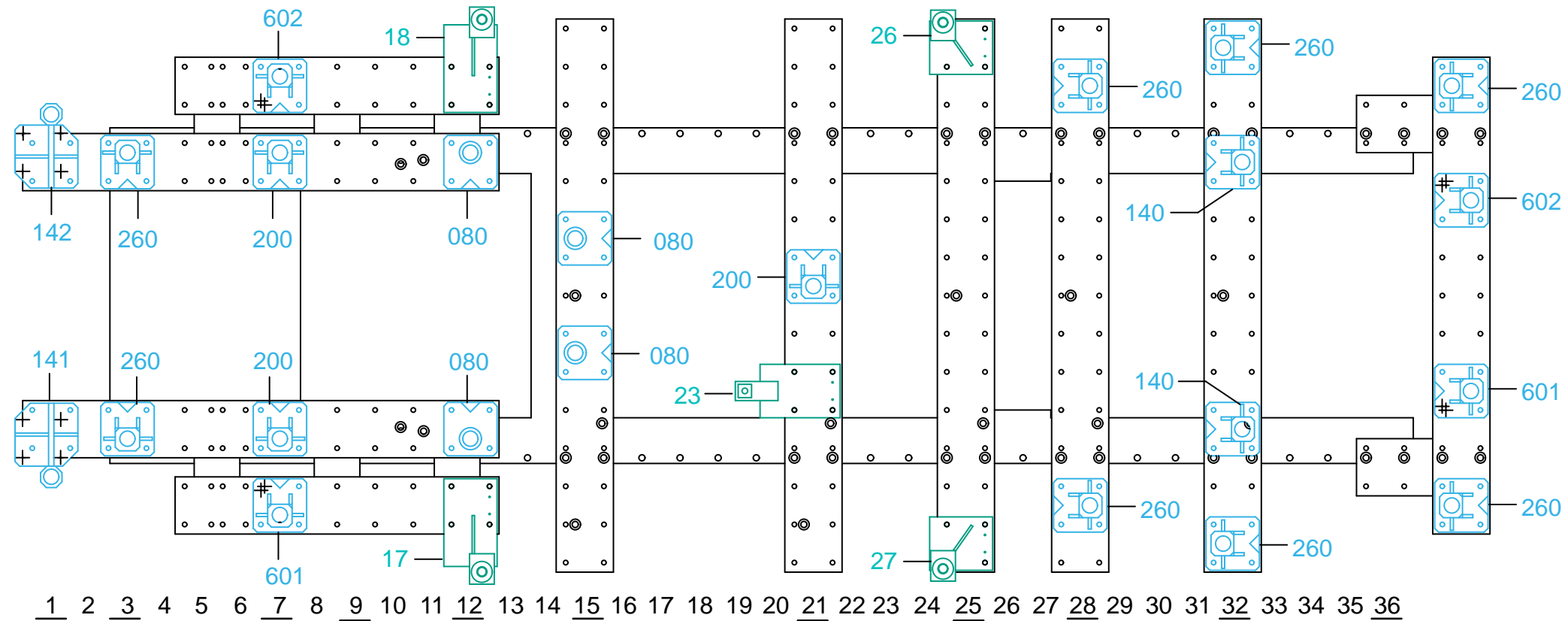

XX Avec ou sans mécanique
 With or without mechanical elements
 Con o senza parti meccaniche
 Mit oder ohne Aggregate
 Con ó sin mecanica desmontada

MERCEDES BENZ

7171.300		
97 Kg	01.12.2003	420-D-31C
7171.300-RVA3-2		00

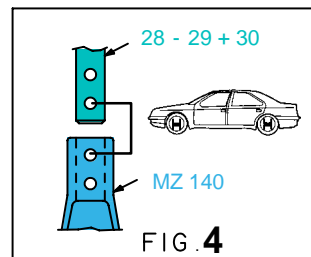
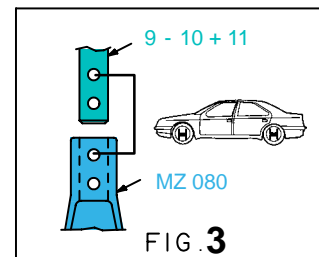
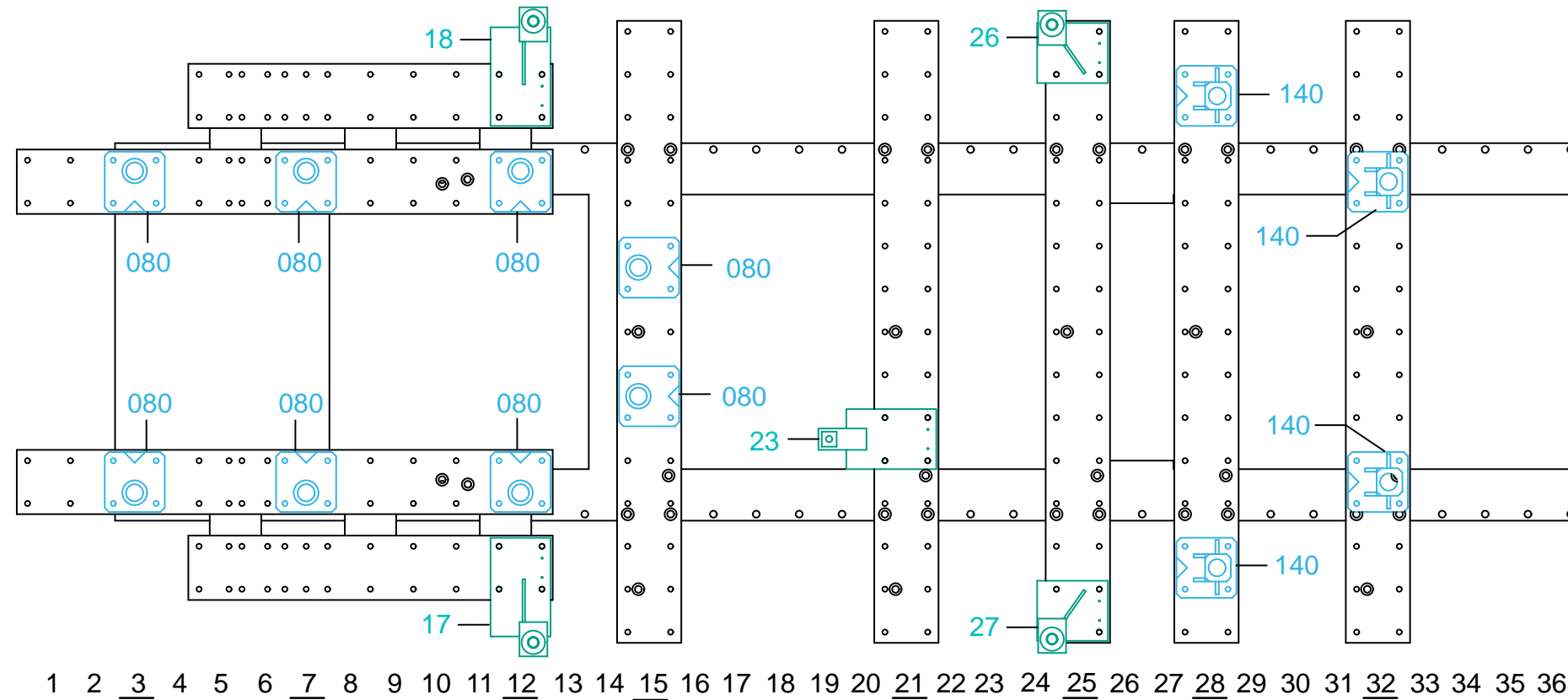

XX Avec ou sans mécanique
With or without mechanical elements
Con o senza parti meccaniche
Mit oder ohne Aggregate
Con ó sin mecánica desmontada

MERCEDES BENZ

7171.300		
97 Kg	01.12.2003	420-D-31D
7171.300-RVA3-2		00

CONTROLE BERCEAU DEPOSE
 KONTROLLE DES INTEGRALTRÄGER
 CHECKING WITHOUT CRADLE IN PLACE
 CONTROLLO SENZA TELAIO
 CONTROL DEL BASTIDOR DESMONTADO

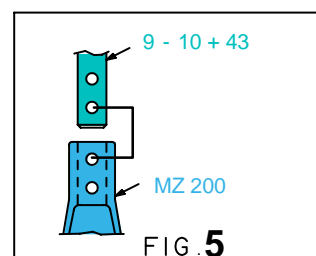
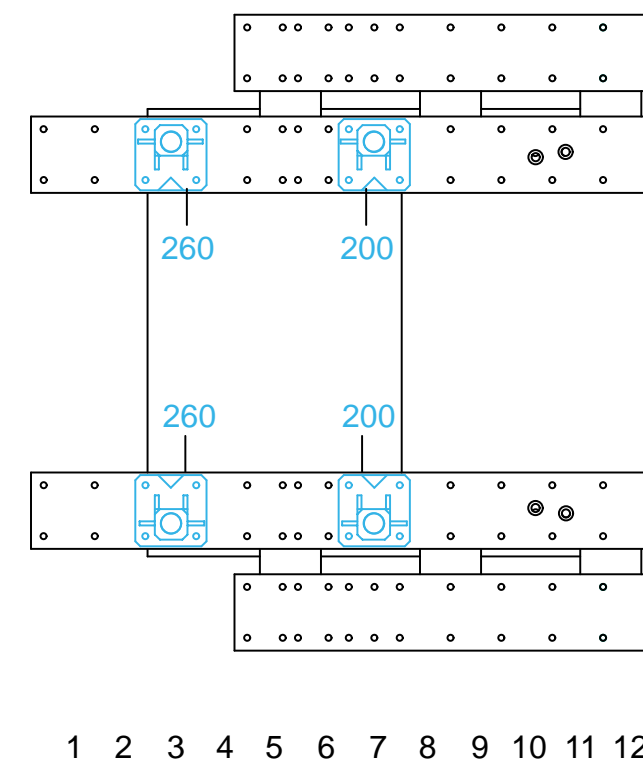
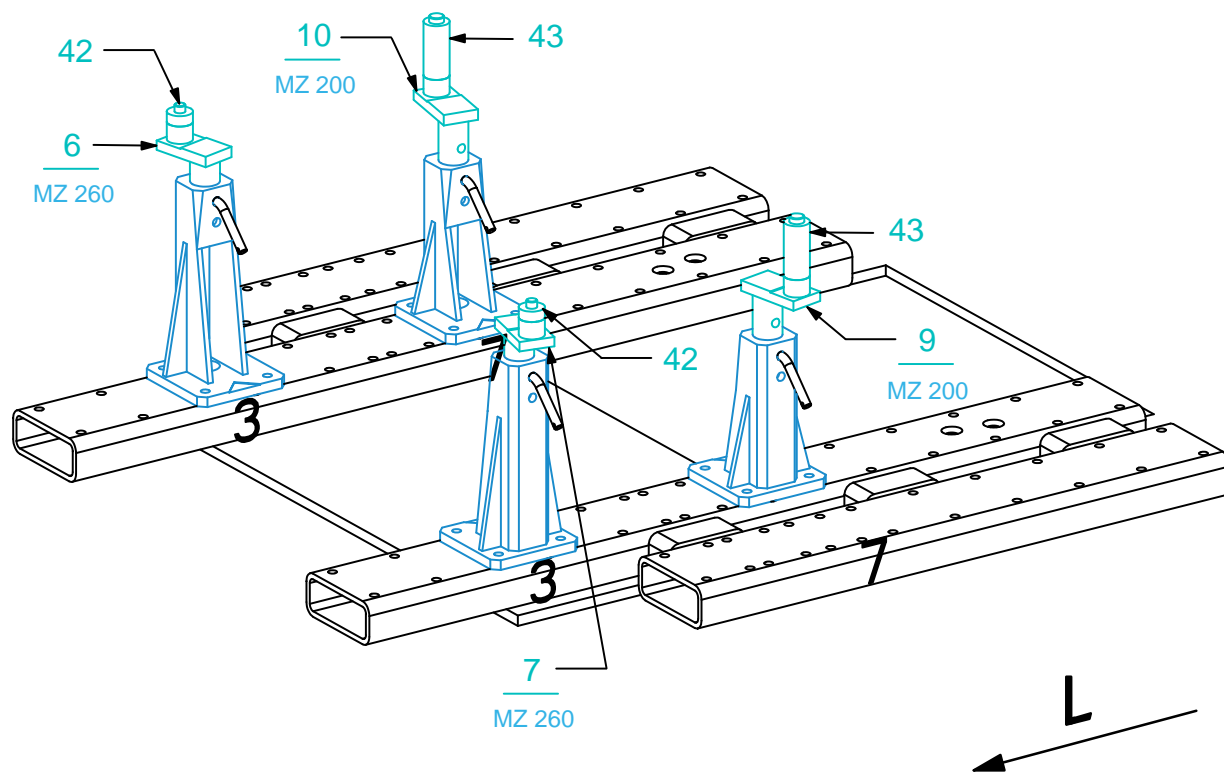

XX Avec ou sans mécanique
 With or without mechanical elements
 Con o senza parti meccaniche
 Mit oder ohne Aggregate
 Con ó sin mecanica desmontada

MERCEDES BENZ

7171.300		
97 Kg	01.12.2003	420-D-31E
7171.300-RVA3-3		01

Réparation
Rebuilding
Riconstruzione
Instandsetzung
Reparación

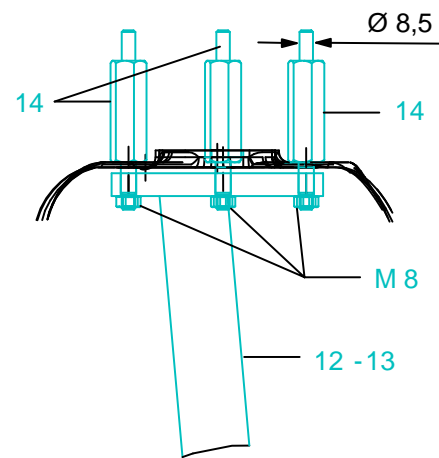

FIG. 6

Contrôle
Checking
Controllo
Überprüfung
Control

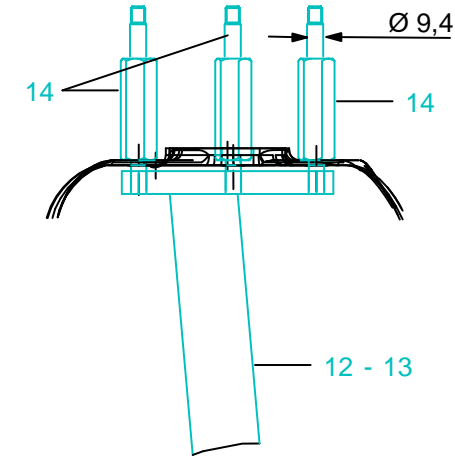

FIG. 7

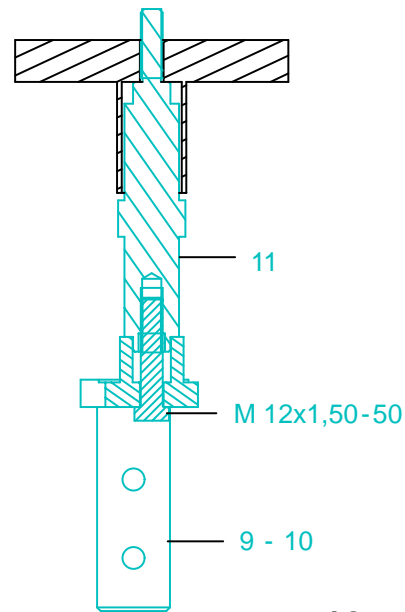
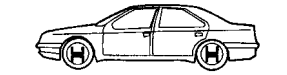

FIG. 10

DIAG.

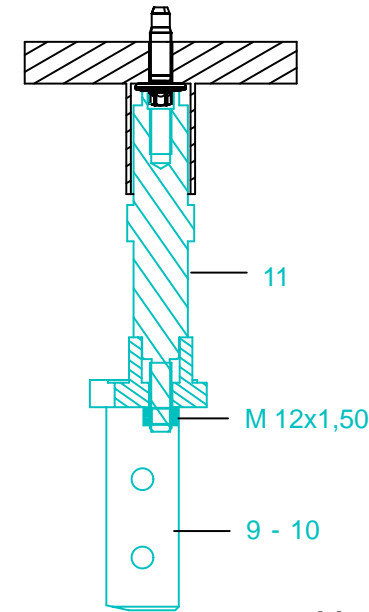

FIG. 11

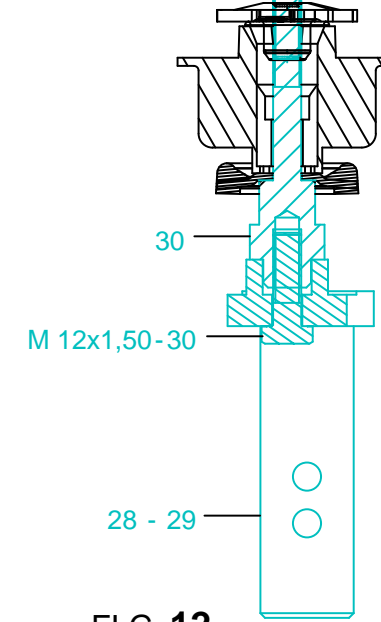

FIG. 12

Contrôle
Checking
Controllo
Überprüfung
Control

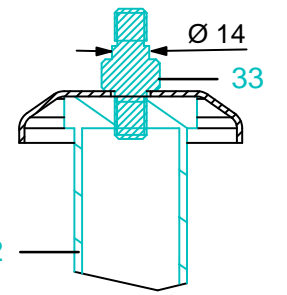

FIG. 13

Réparation
Rebuilding
Riconstruzione
Instandsetzung
Reparación

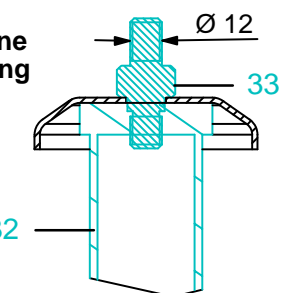

FIG. 14

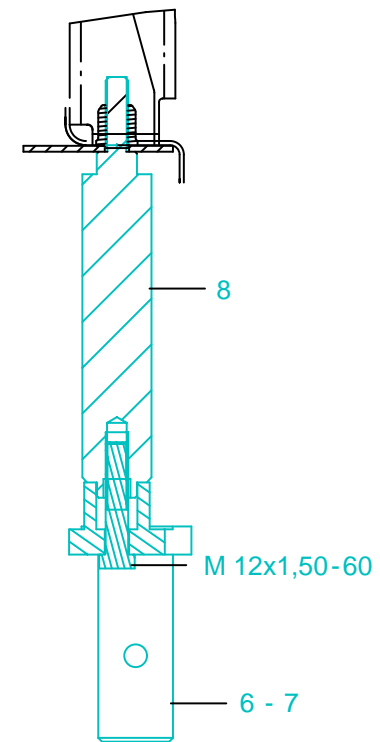
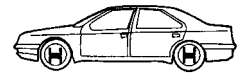

FIG. 8

DIAG.

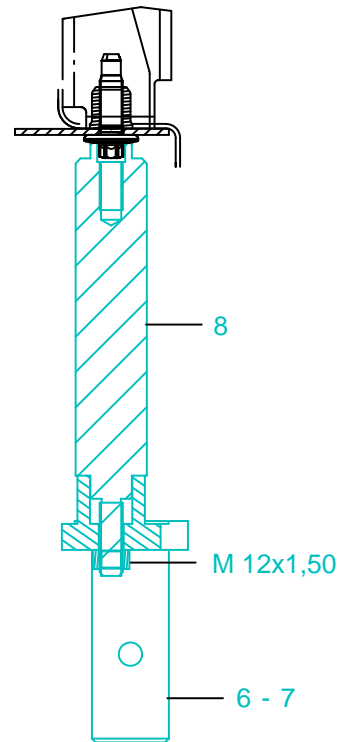

FIG. 9

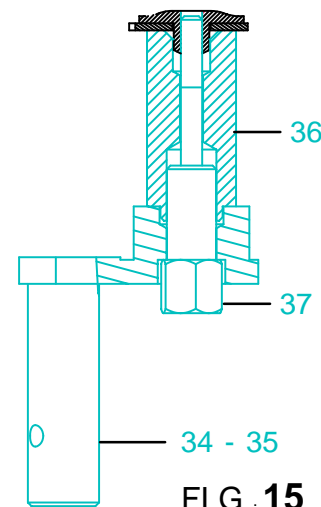
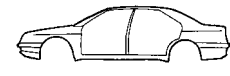

FIG. 15

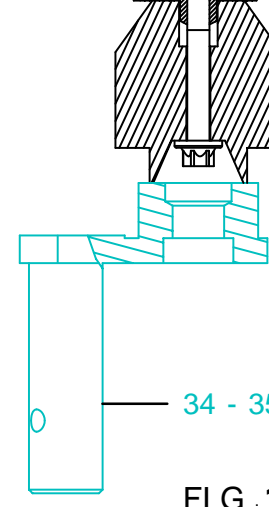

FIG. 16

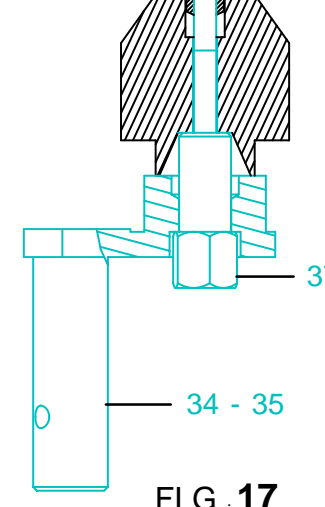

FIG. 17

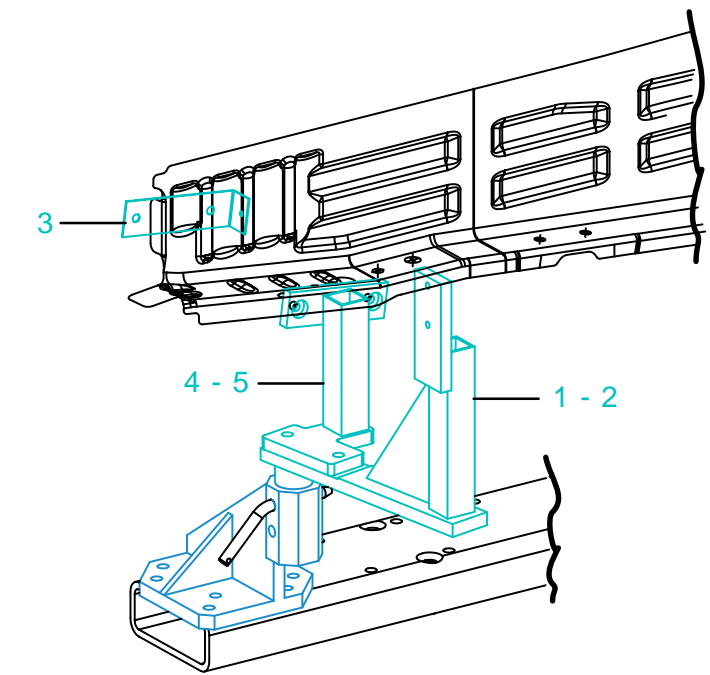

FIG. 18