

ANCRAGE DU VEHICULE
ANCHORING OF THE VEHICLE
VERANKERUNG DES FAHRZEUGS
ANCORAGGIO DEL VEICOLO
ANCLAJE DEL VEHICULO

AN.27 (MUF7 - M8S - MT10)
Ou/Or/Oder/O
AN.27.B (SVN)

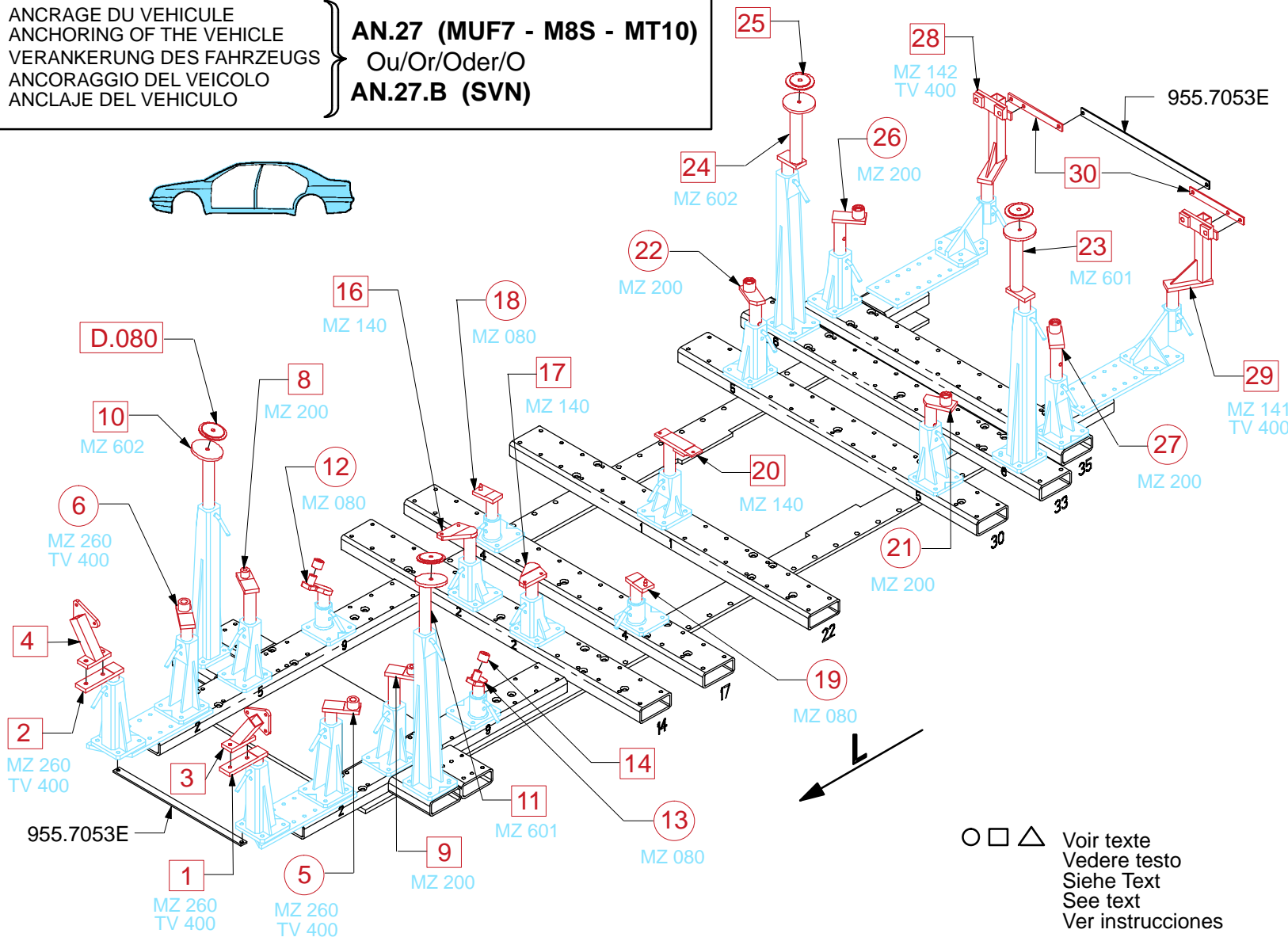

REP.	REFERENCE	PDS	NB	MZ
1	716.7001	1,7	1	260
2	716.7002	1,7	1	260
3	716.7003	1,6	1	
4	716.7004	1,6	1	
5	716.7005	2,2	1	080/260
6	716.7006	2,2	1	080/260
7	716.7007	0,5	2	
8	716.7008	2,7	1	200
9	716.7009	2,7	1	200
10	716.7010	1,9	1	602
11	716.7011	1,9	1	601
12	716.7012	1,7	1	080
13	716.7013	1,7	1	080
14	716.7014	0,2	2	
16	716.7016	2,5	1	140
17	716.7017	2,5	1	140
18	716.7018	1,9	1	080
19	716.7019	1,9	1	080
20	716.7020	3,0	1	140
21	716.7021	2,3	1	140/200
22	716.7022	2,3	1	140/200
23	716.7023	3,0	1	601
24	716.7024	3,0	1	602
25	716.7025	0,4	2	
26	716.7026	2,7	1	200
27	716.7027	2,7	1	200
28	716.7028	4,8	1	142
29	716.7029	4,8	1	141
30	716.7030	0,3	2	
31	716.7031	0,3	2	
32	716.7032	0,05	2	
	D.080	0,5	2	

M 8x25	4
M 12x20	6
M 12x25	2
M 12x30	8
M 12x45	2
M 12.150x40	2
M 12.150x70	2
M 12.150x80	2
M 14.150x45	4
M 14.150x130	4
M 16x40	4
M 8	8
M 12	4
M 16	4
M 12	2

○ □ △ Voir texte
Vedere testo
Siehe Text
See text
Ver instrucciones

BMW

716.300

67 Kg 25.08.95 406-D-14A

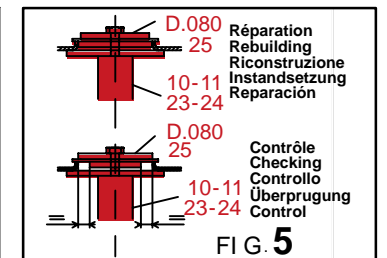
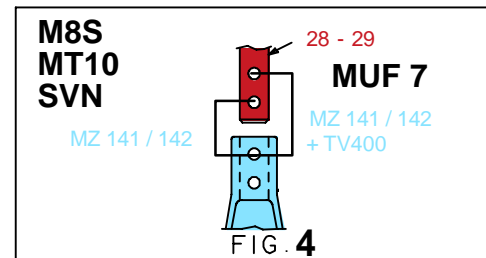
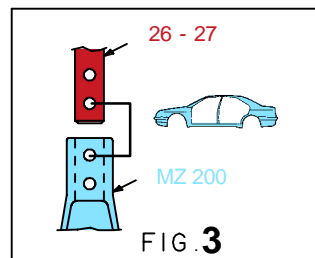
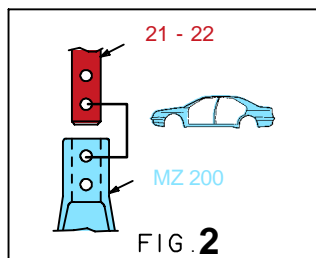
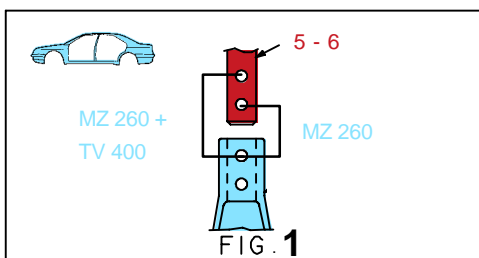
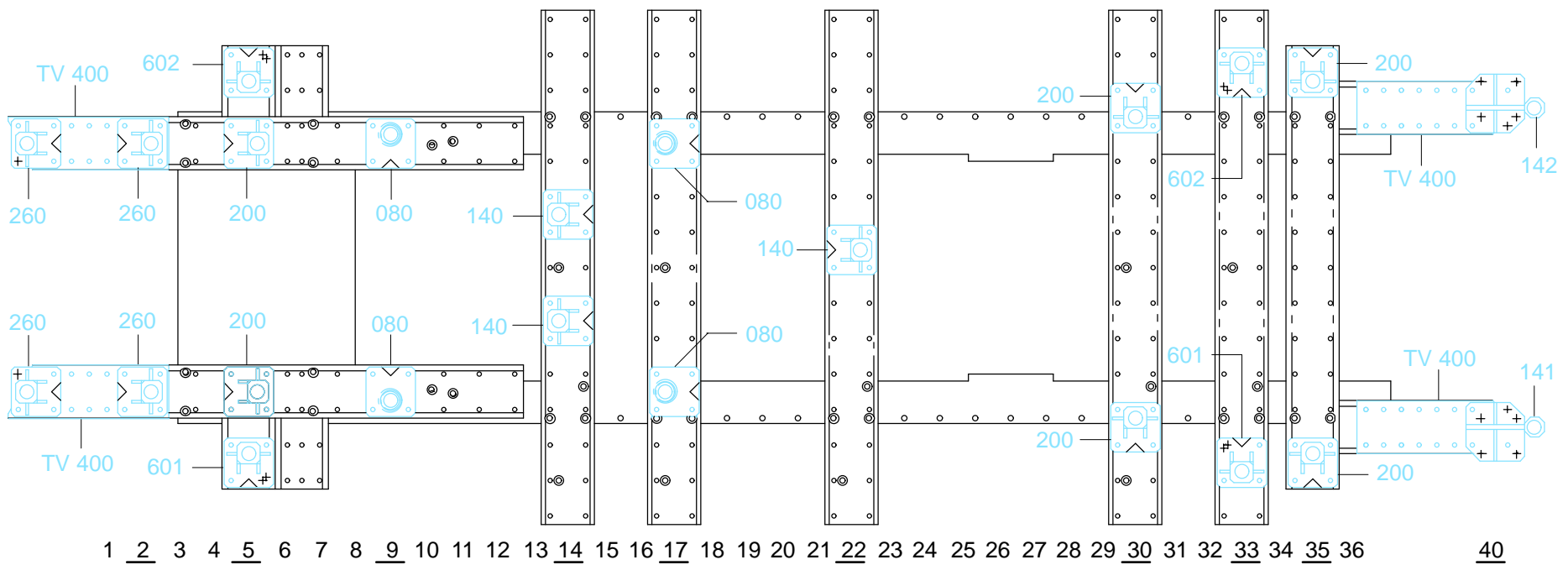

ANCRAGE DU VEHICULE
ANCHORING OF THE VEHICLE
VERANKERUNG DES FAHRZEUGS
ANCORAGGIO DEL VEICOLO
ANCLAJE DEL VEHICULO

AN.27 (MUF7 - M8S - MT10)
Ou/Or/Oder/O
AN.27.B (SVN)



32
Berceau Tole acier
Steel sheet cradle
Motorträger aus Stahlblech
Telaio in lamiera d'acciaio
Cojinete lamina de acero

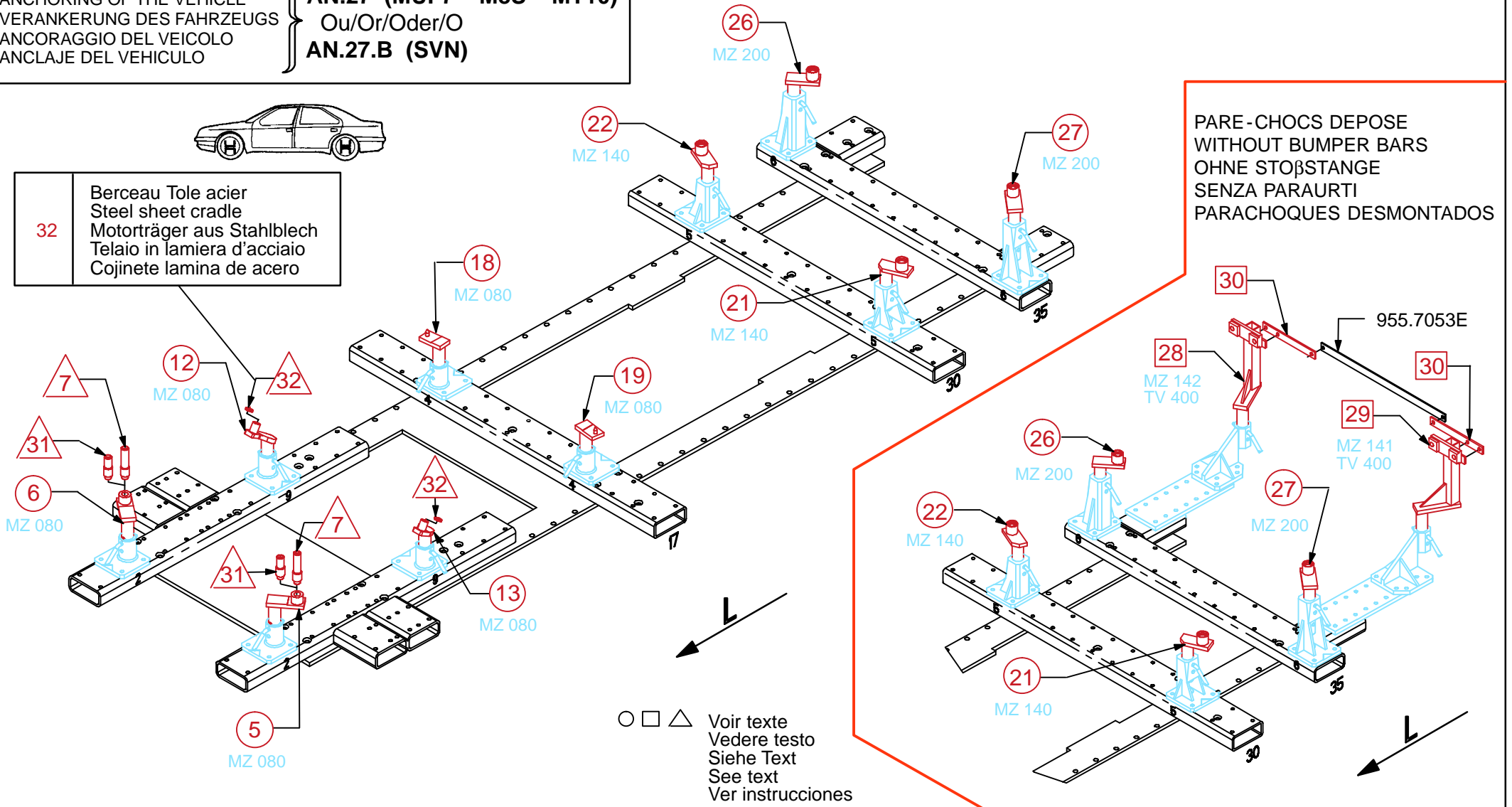

○ □ △ Voir texte
Vedere testo
Siehe Text
See text
Ver instrucciones

BMW

PARE-CHOC DEPOSE
WITHOUT BUMPER BARS
OHNE STOßSTANGE
SENZA PARAURTI
PARACHOQUES DESMONTADOS

716.300

67 Kg	30.08.99	406-D-14B
-------	----------	-----------

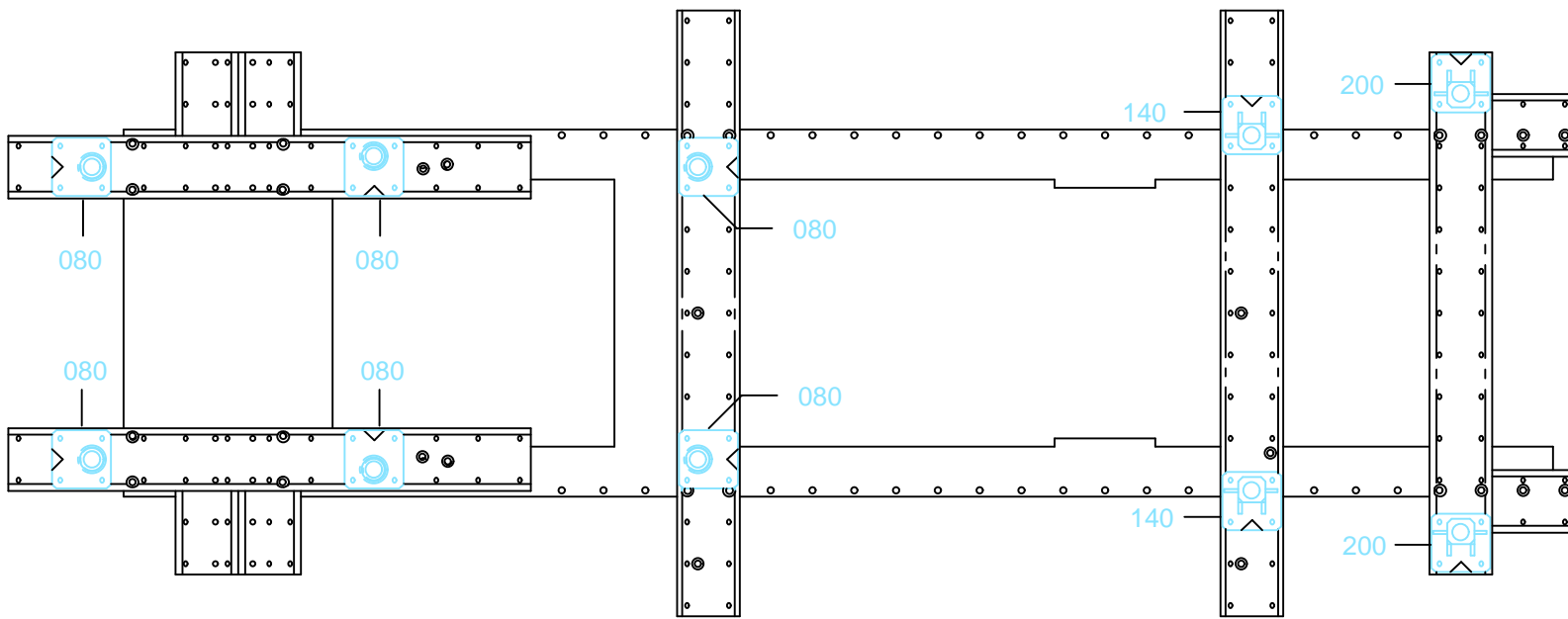

REP.	MODELE
7	Berceau Aluminium Aluminium cradle Motorträger aus Aluminium Telaio di alluminio Cojinete Aluminio
31	Berceau Tole acier Steel sheet cradle Motorträger aus Stahlblech Telaio in lamiera d'acciaio Cojinete lamina de acero

1 2 3 4 5 6 7 8 9 10 11 12 13 14 15 16 17 18 19 20 21 22 23 24 25 26 27 28 29 30 31 32 33 34 35 36

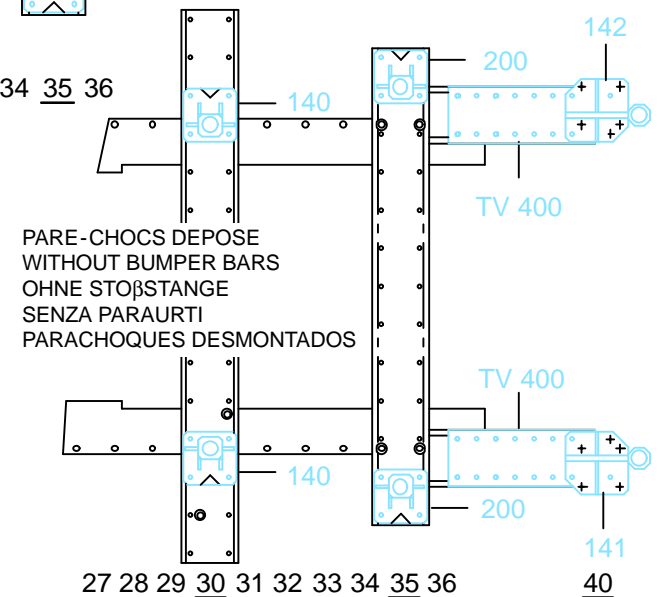
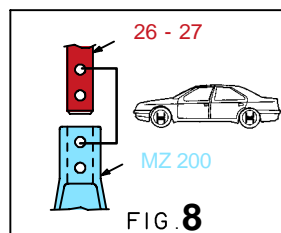
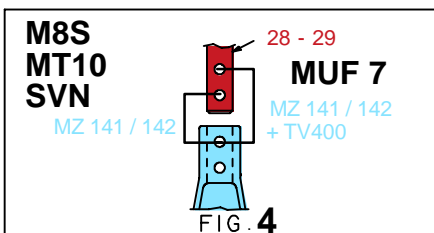
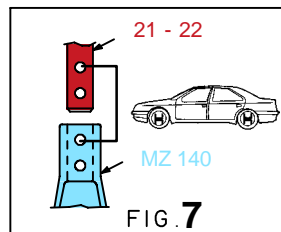
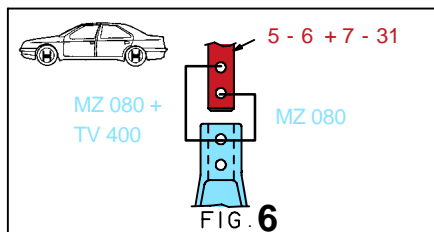
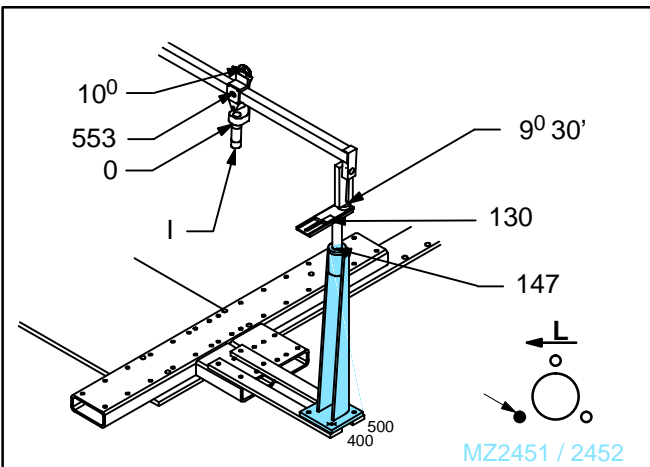

PARE-CHOC DEPOSE
WITHOUT BUMPER BARS
OHNE STOßSTANGE
SENZA PARAURTI
PARACHOQUES DESMONTADOS

ANCRAGE DU VEHICULE
ANCHORING OF THE VEHICLE
VERANKERUNG DES FAHRZEUGS
ANCORAGGIO DEL VEICOLO
ANCLAJE DEL VEHICULO

AN.27 (MUF7 - M8S - MT10)
Ou/Or/Oder/O
AN.27.B (SVN)

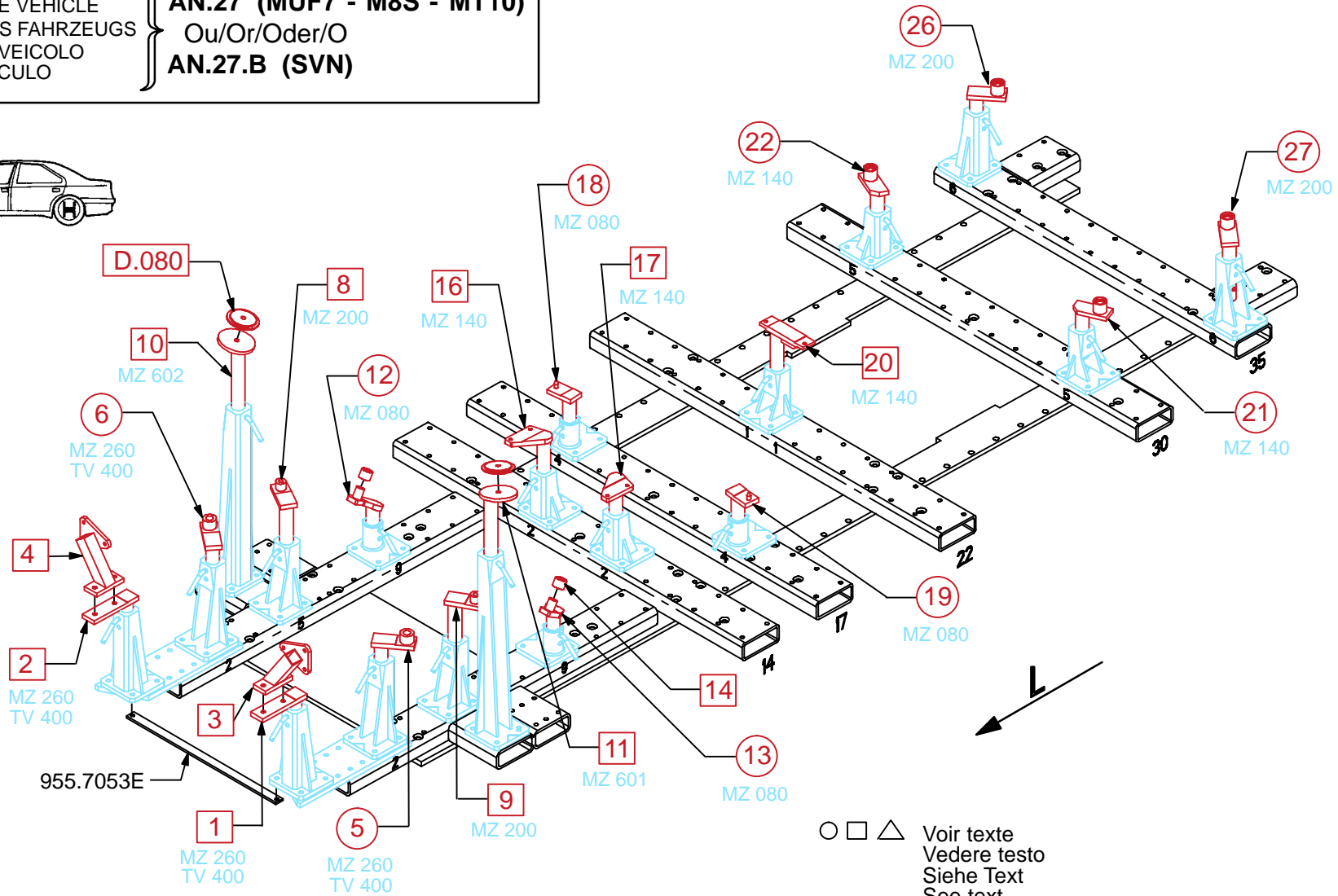
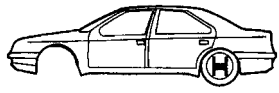

BMW

716.300

67 Kg 30.08.99 406-D-14C

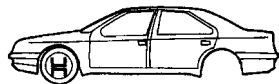

32 Berceau Tole acier
Steel sheet cradle
Motorträger aus Stahlblech
Telaio in lamiera d'acciaio
Cojinete lamina de acero

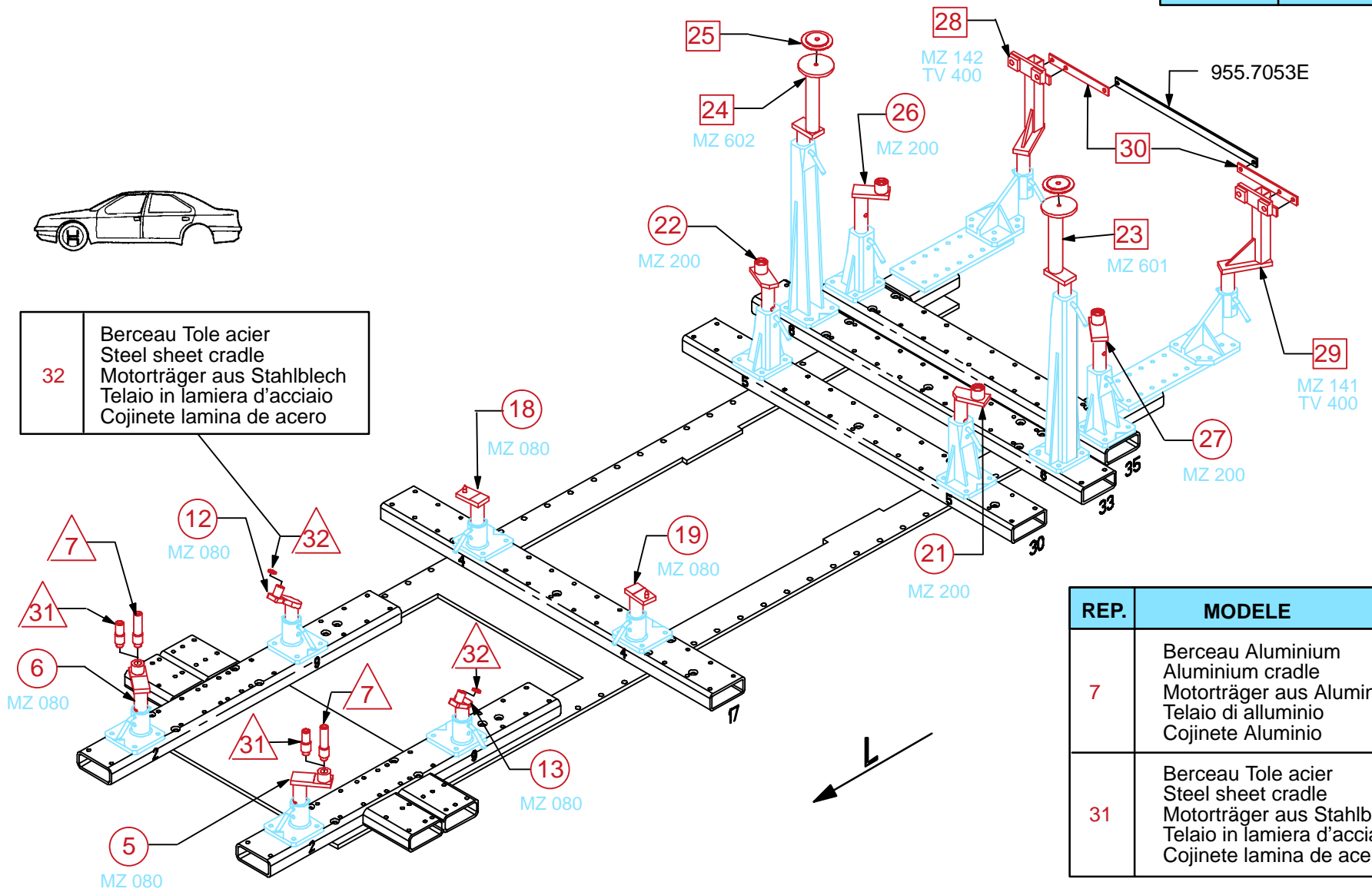

REP.	MODELE
7	Berceau Aluminium Aluminium cradle Motorträger aus Aluminium Telaio di alluminio Cojinete Aluminio
31	Berceau Tole acier Steel sheet cradle Motorträger aus Stahlblech Telaio in lamiera d'acciaio Cojinete lamina de acero