

○ Avec ou sans mécanique
With or without mechanical elements
Con o senza parti meccaniche
Mit oder ohne Aggregate
Con ó sin mecanica desmontada

REP.	REFERENCE	PDS	NB	MZ
1	708.7001	3,4	1	080
2	708.7002	2,0	1	142
3	708.7003	2,0	1	141
4	708.7004	0,3	2	
5	708.7005	2,5	1	601
6	708.7006	2,5	1	602
7	708.7007	0,6	2	
8	708.7008	1,0	1	200
9	708.7009	4,0	1	
10	708.7010	2,5	1	080
11	708.7011	2,5	1	080
12	708.7012	0,1	2	
13	708.7013	1,8	1	080
14	708.7014	1,8	1	080
15	708.7015	1,8	1	140
16	708.7016	1,8	1	140
17	708.7017	3,5	1	260
18	708.7018	3,5	1	260
19	708.7019	2,3	1	601
20	708.7020	2,3	1	602
21	708.7021	0,7	2	
22	708.7022	2,1	1	260/200
23	708.7023	2,1	1	260/200
24	708.7024	0,4	2	
25	708.7025	2,1	1	142
26	708.7026	2,1	1	141
	V.32	0,1	2	

M 8x20	6
M 10.125x70	2
M 10.125x90	2
M 10.125x125	2
M 12x30	4
M 12.125x40	1
M 12.125x50	4
M 14.150x70	2
M 14.150x100	2

M 12	2
------	---

TOYOTA

708.300

55 Kg 19.09.95 434-D-52A

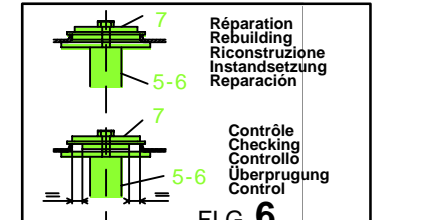
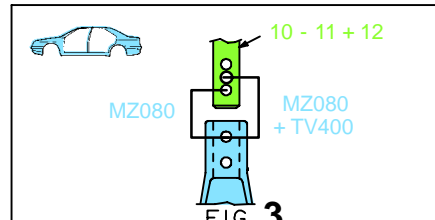
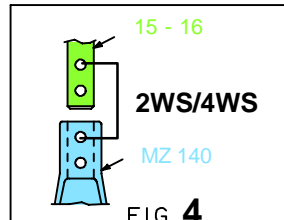
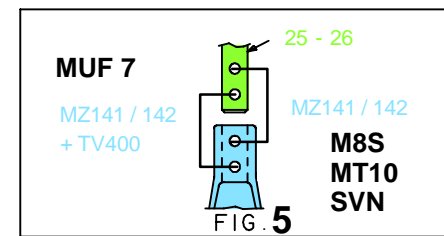
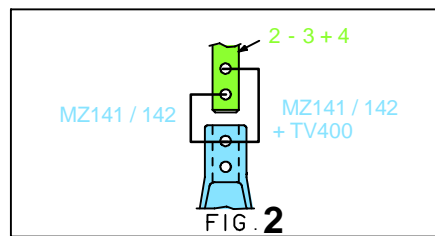
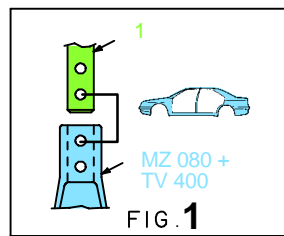
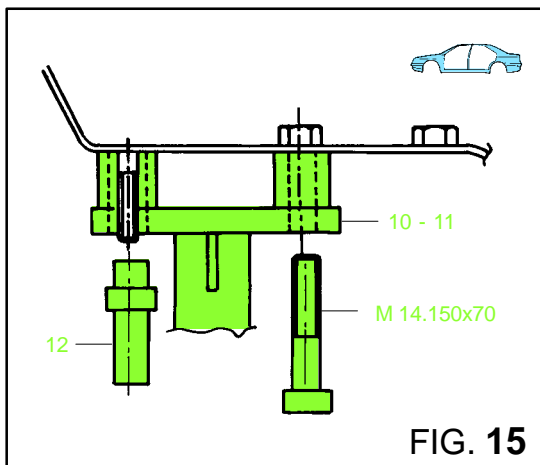
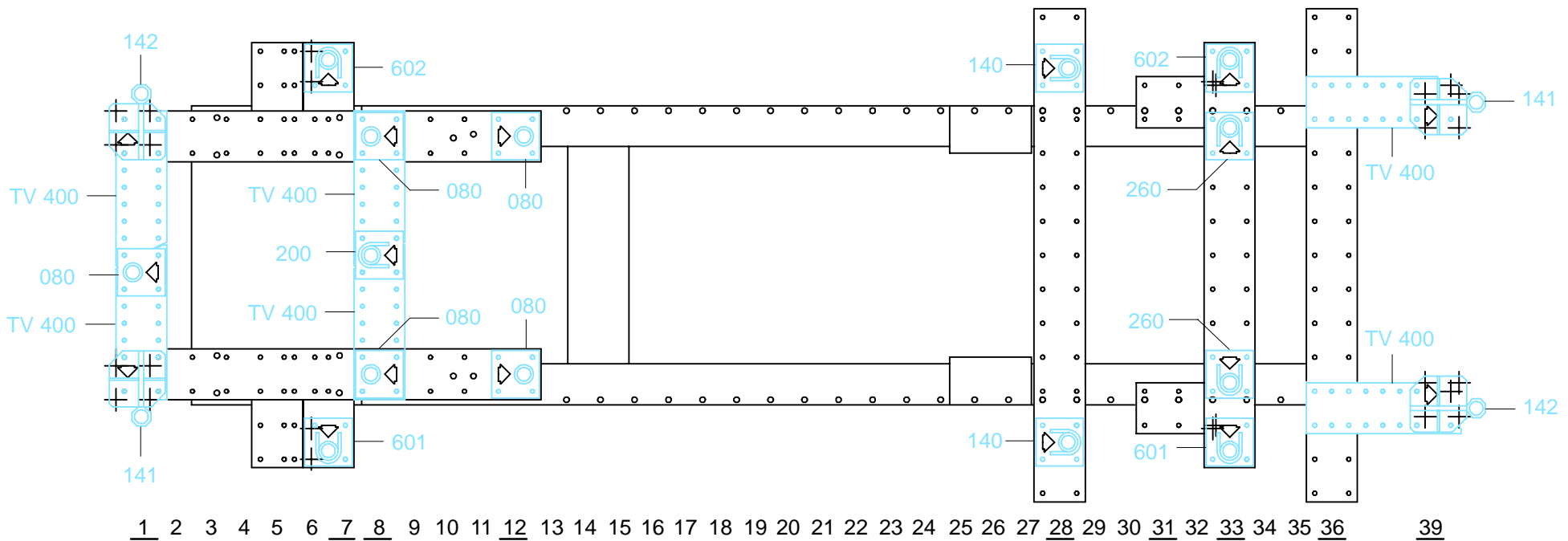

4WS

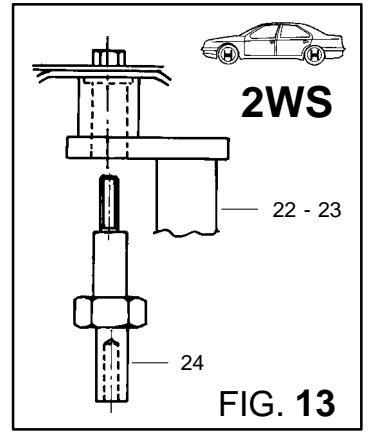
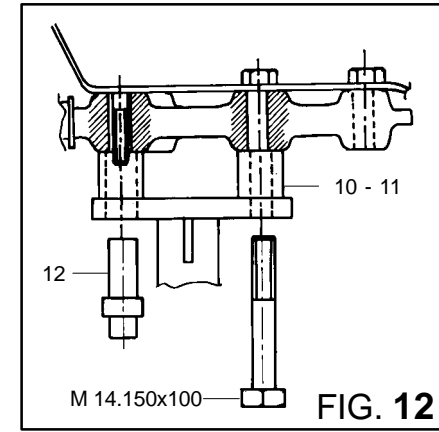
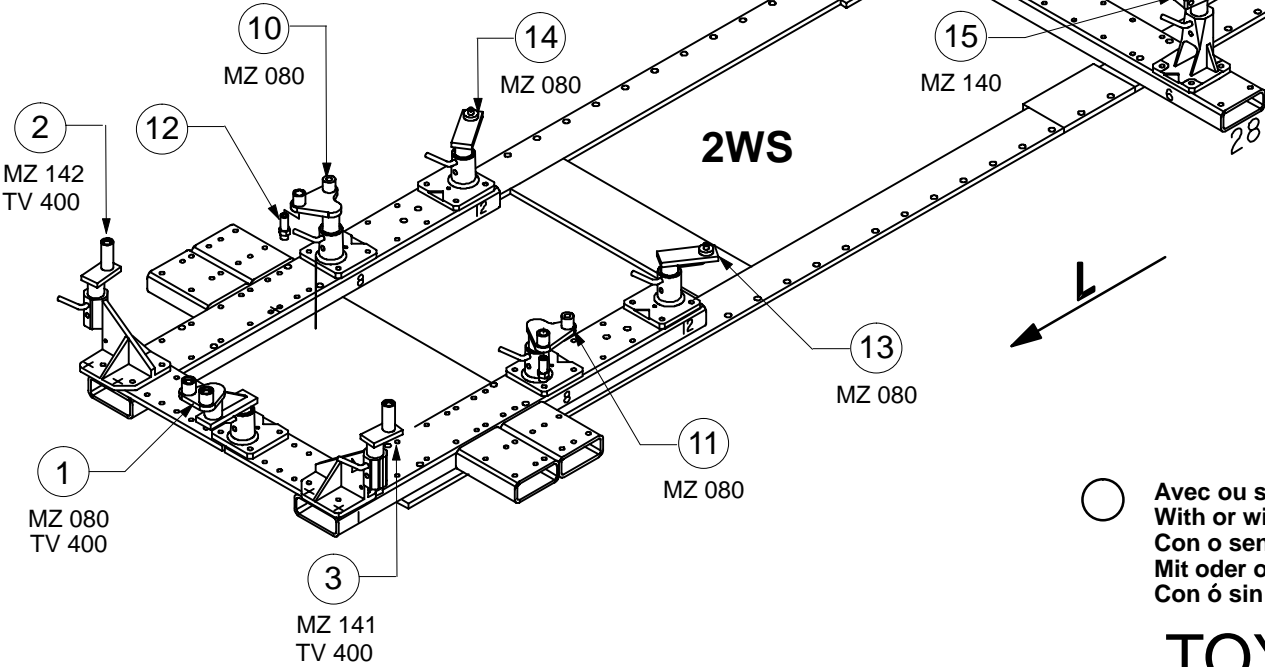
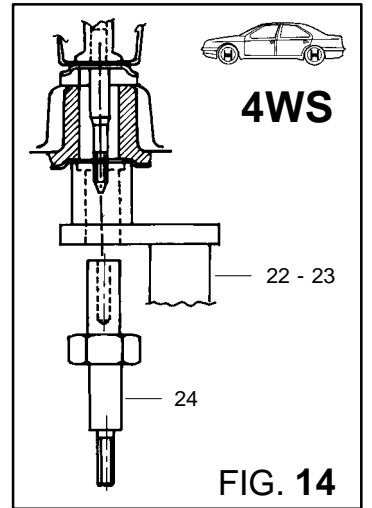
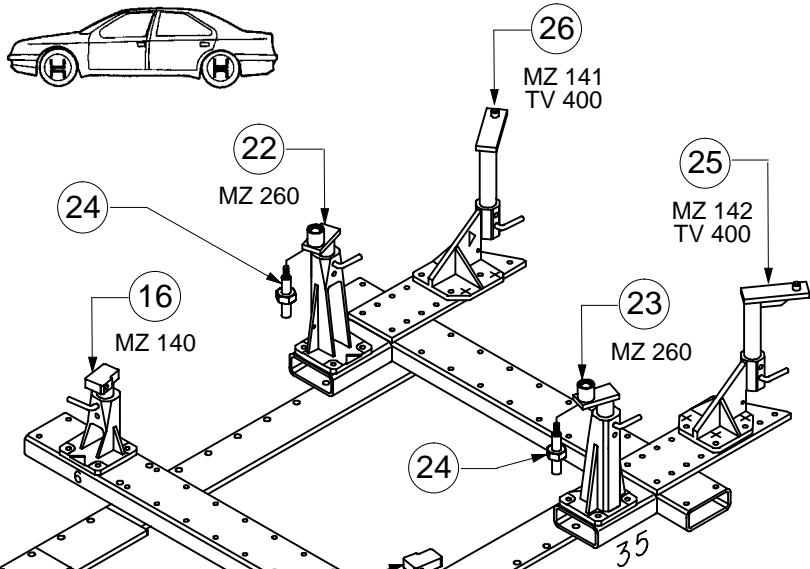
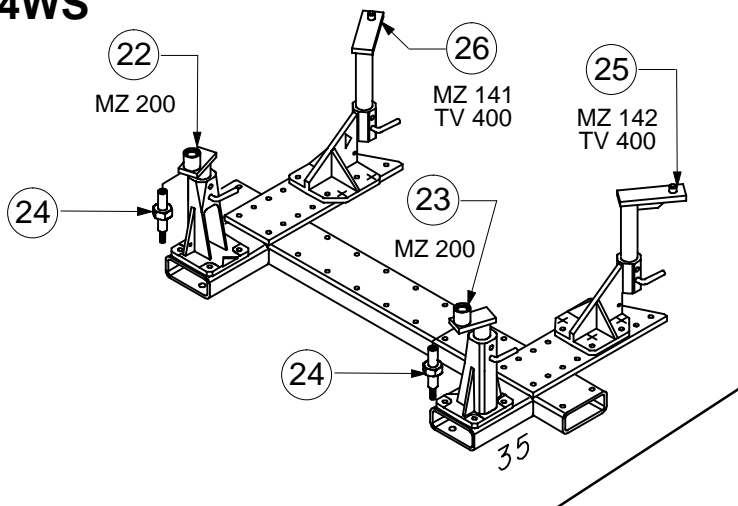

○ Avec ou sans mécanique
With or without mechanical elements
Con o senza parti meccaniche
Mit oder ohne Aggregate
Con ó sin mecanica desmontada

TOYOTA

708.300

55 Kg | 19.09.95 | 434-D-52B

