

ANCRAGE DU VEHICULE
ANCHORING OF THE VEHICLE
VERANKERUNG DES FAHRZEUGS
ANCORAGGIO DEL VEICOLO
ANCLAJE DEL VEHICULO

AN.27 + AN.27.01 + AN.27.02
Ou/Or/Oder/O
AN.27.B

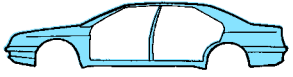

**M8S
MT10
SVN**

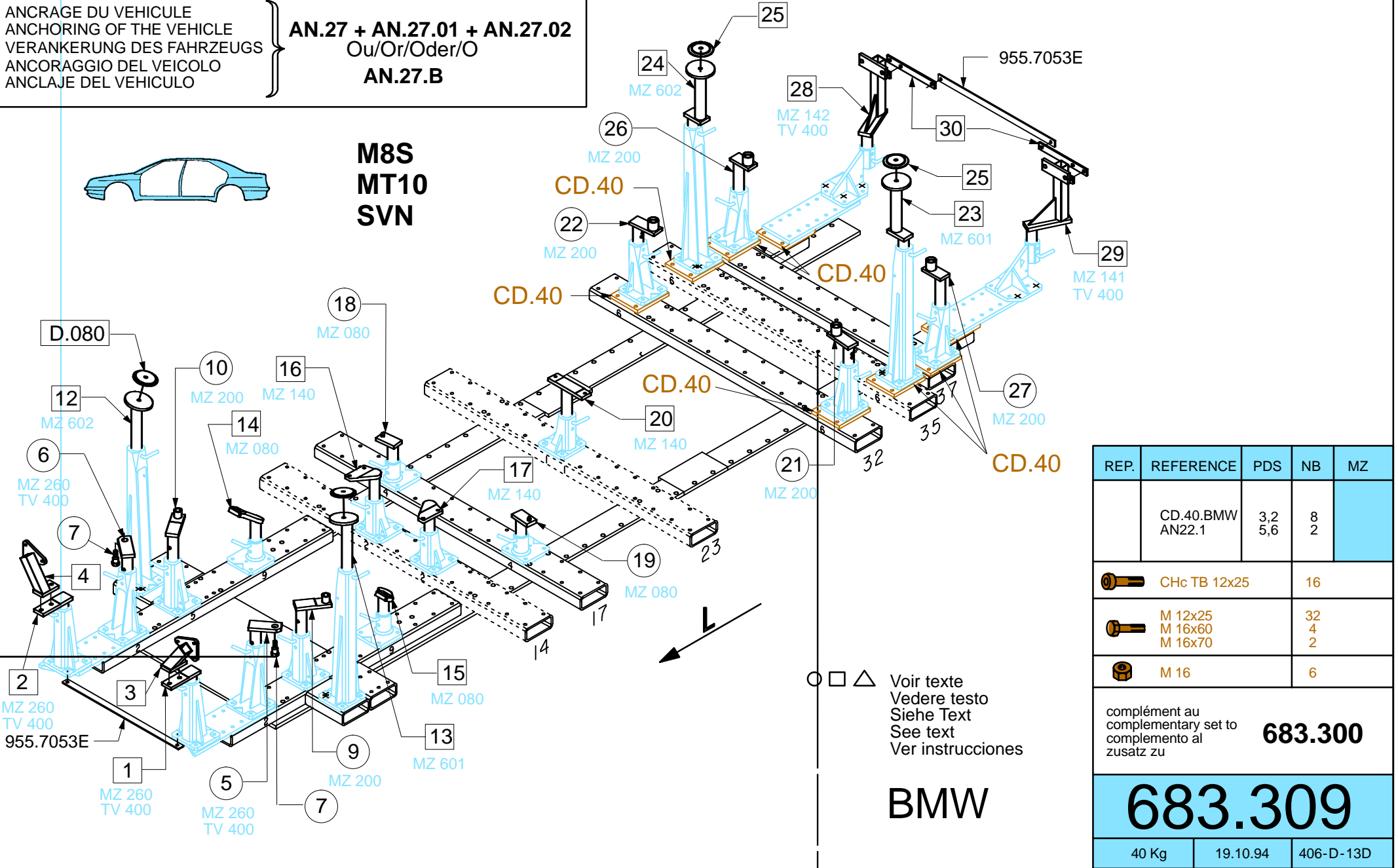

REP.	REFERENCE	PDS	NB	MZ
	CD.40.BMW AN22.1	3,2 5,6	8 2	
	CHc TB 12x25		16	
	M 12x25 M 16x60 M 16x70		32 4 2	
	M 16		6	
complément au complementary set to complemento al zusatz zu				683.300
683.309				
40 Kg	19.10.94	406-D-13D		

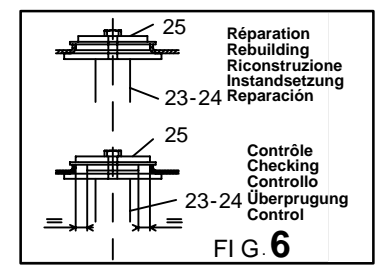
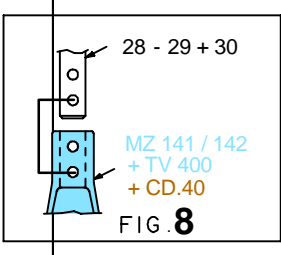
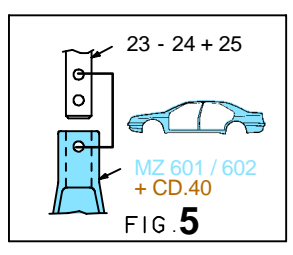
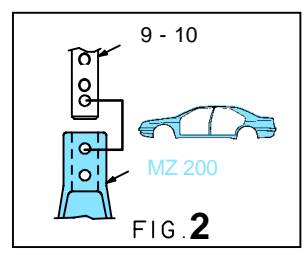
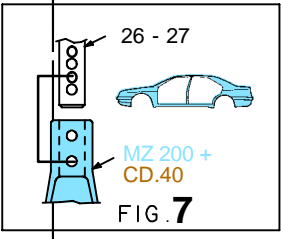
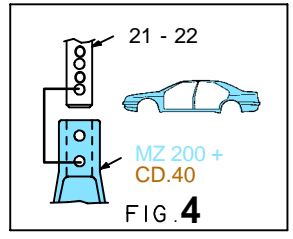
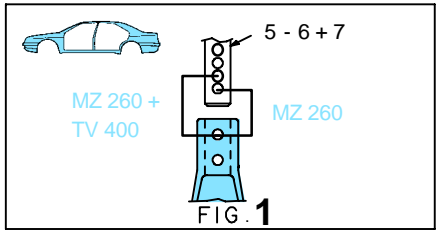
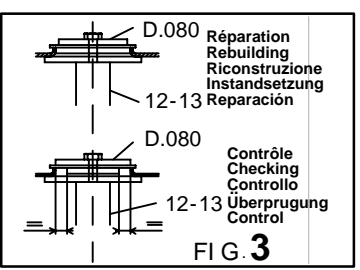
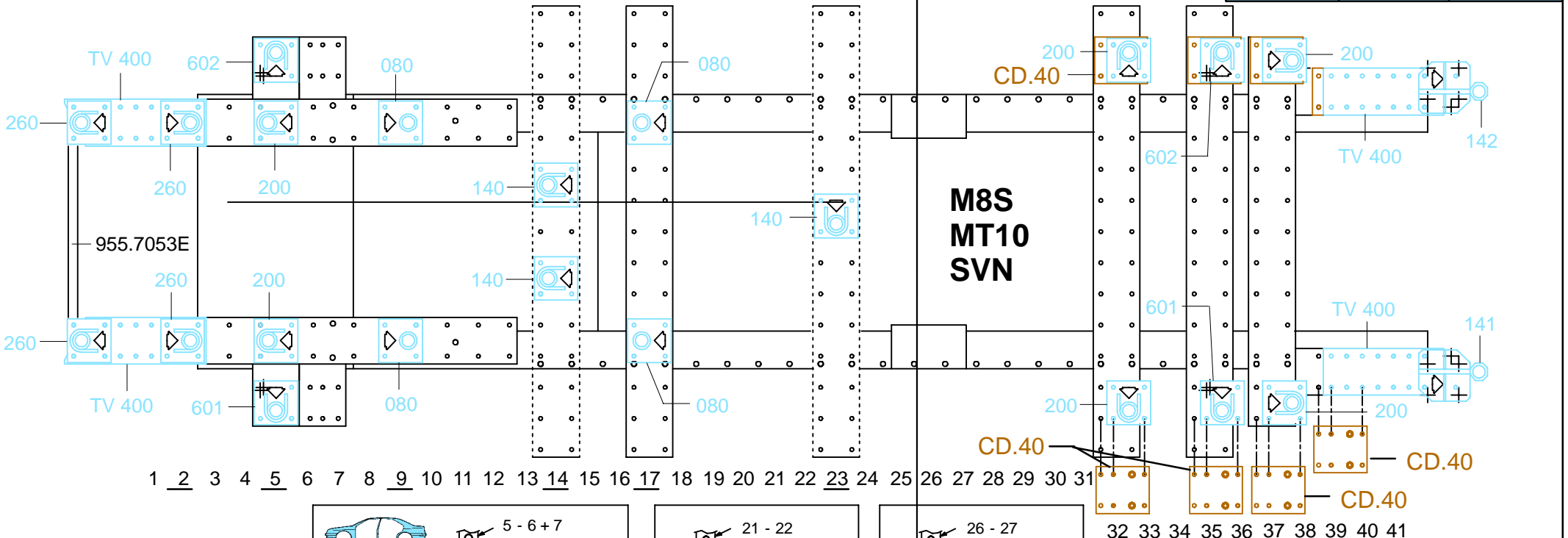

ANCRAGE DU VEHICULE
ANCHORING OF THE VEHICLE
VERANKERUNG DES FAHRZEUGS
ANCORAGGIO DEL VEICOLO
ANCLAJE DEL VEHICULO

AN.27 + AN.27.01 + AN.27.02
Ou/Or/Oder/O
AN.27.B

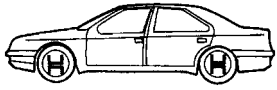

MUF 7

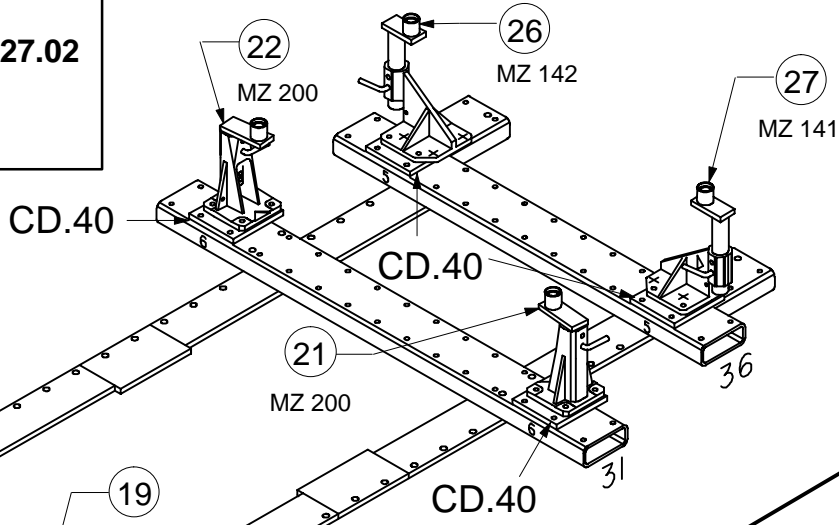
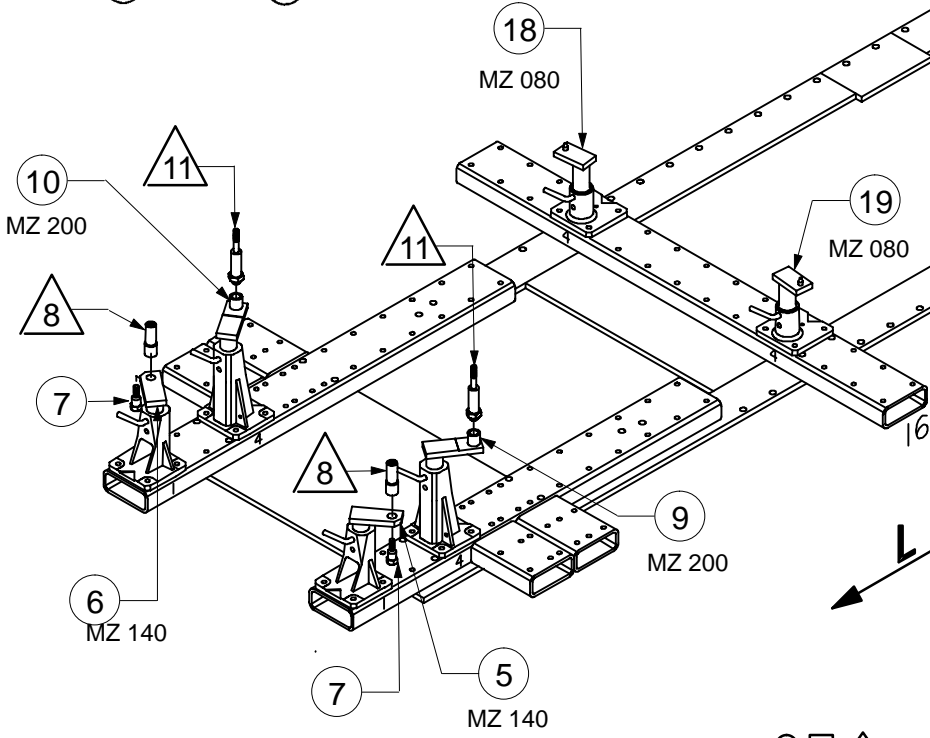

PARE-CHOC DEPOSE
WITHOUT BUMPER BARS
OHNE STOßSTANGE
SENZA PARAURTI
PARACHOQUES DESMONTADOS

MUF 7

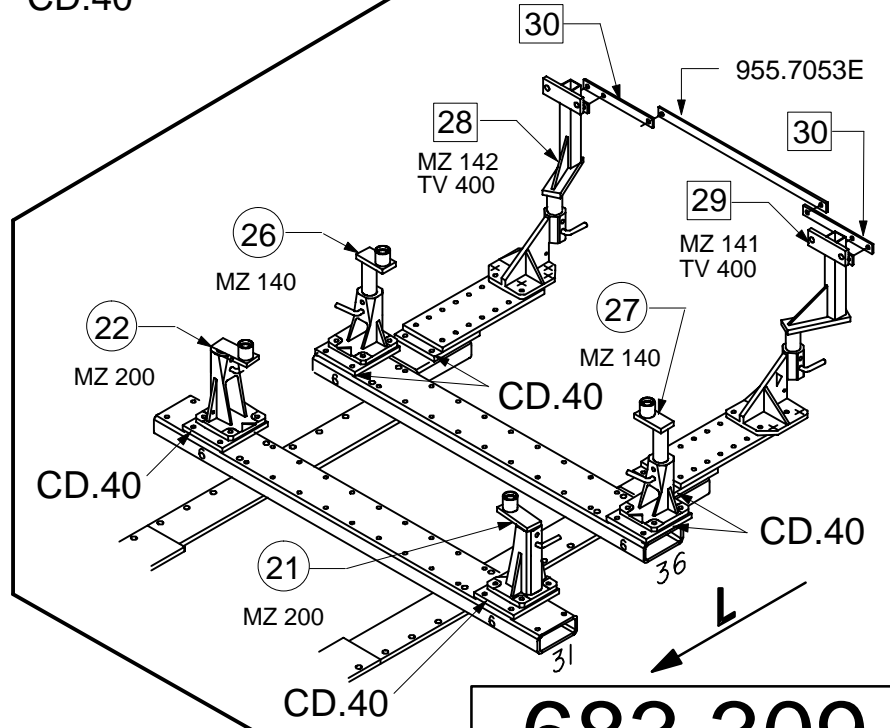

○ □ △ Voir texte
Vedere testo
Siehe Text
See text
Ver instrucciones

BMW

683.309

40 Kg 05.09.94 406-D-13E

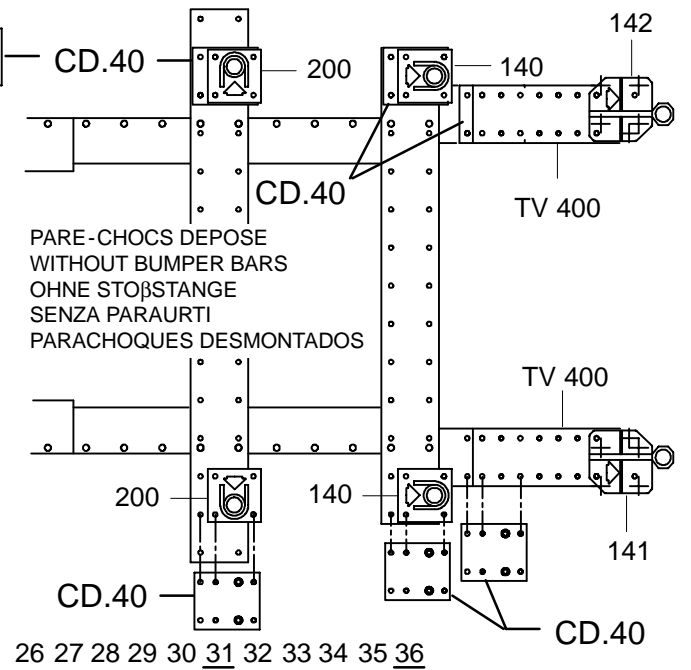
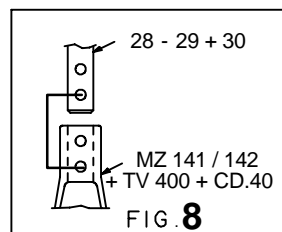
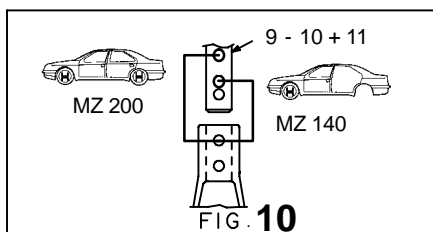
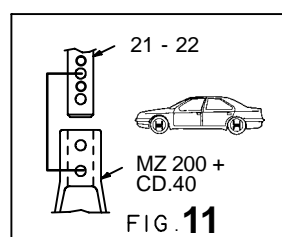
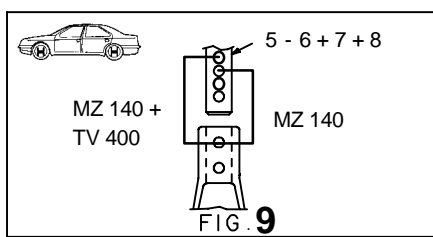
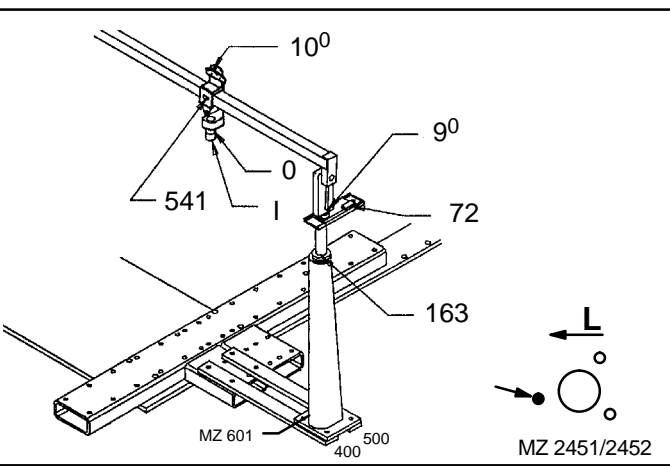
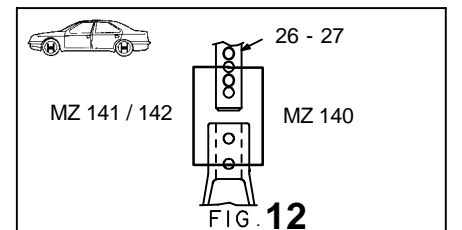
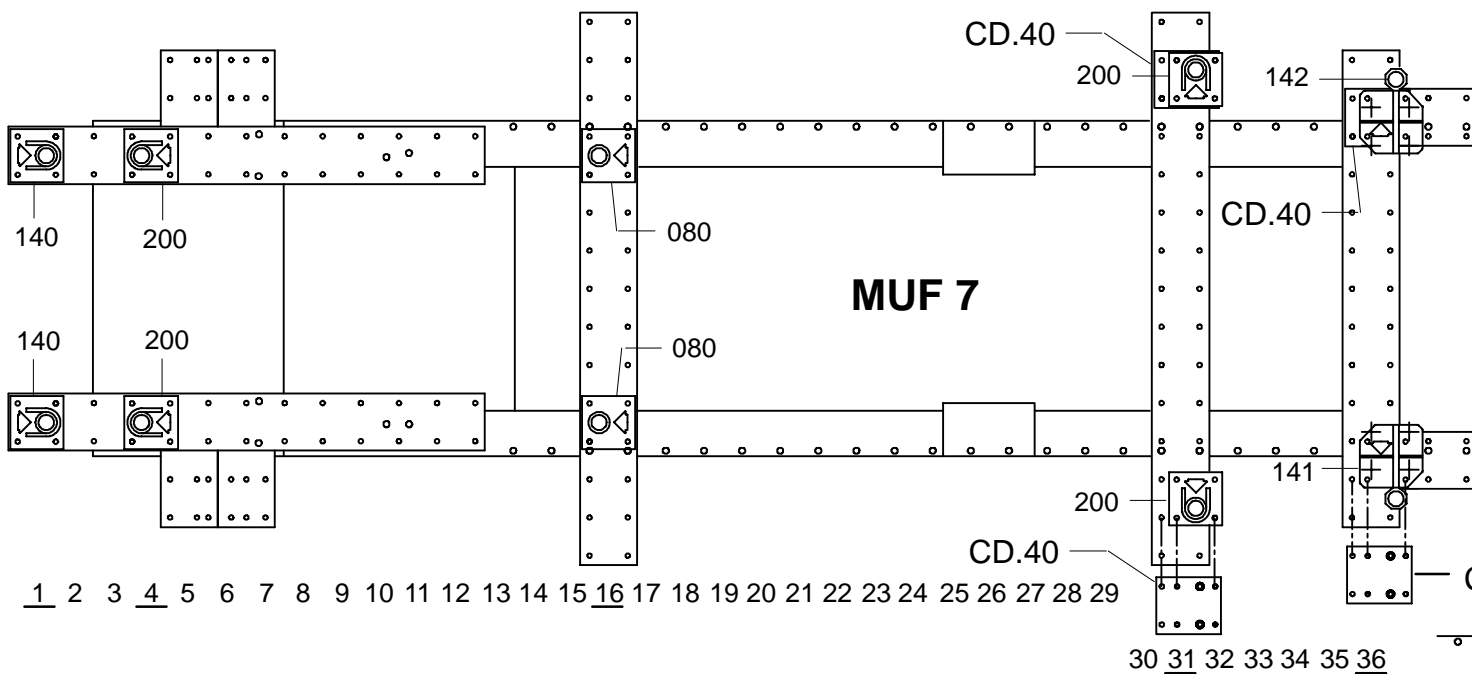

PARE-CHOC DEPOSE
WITHOUT BUMPER BARS
OHNE STOßSTANGE
SENZA PARAURTI
PARACHOQUES DESMONTADOS

ANCRAGE DU VEHICULE
ANCHORING OF THE VEHICLE
VERANKERUNG DES FAHRZEUGS
ANCORAGGIO DEL VEICOLO
ANCLAJE DEL VEHICULO

AN.27 + AN.27.01 + AN.27.02
Ou/Or/Oder/O
AN.27.B

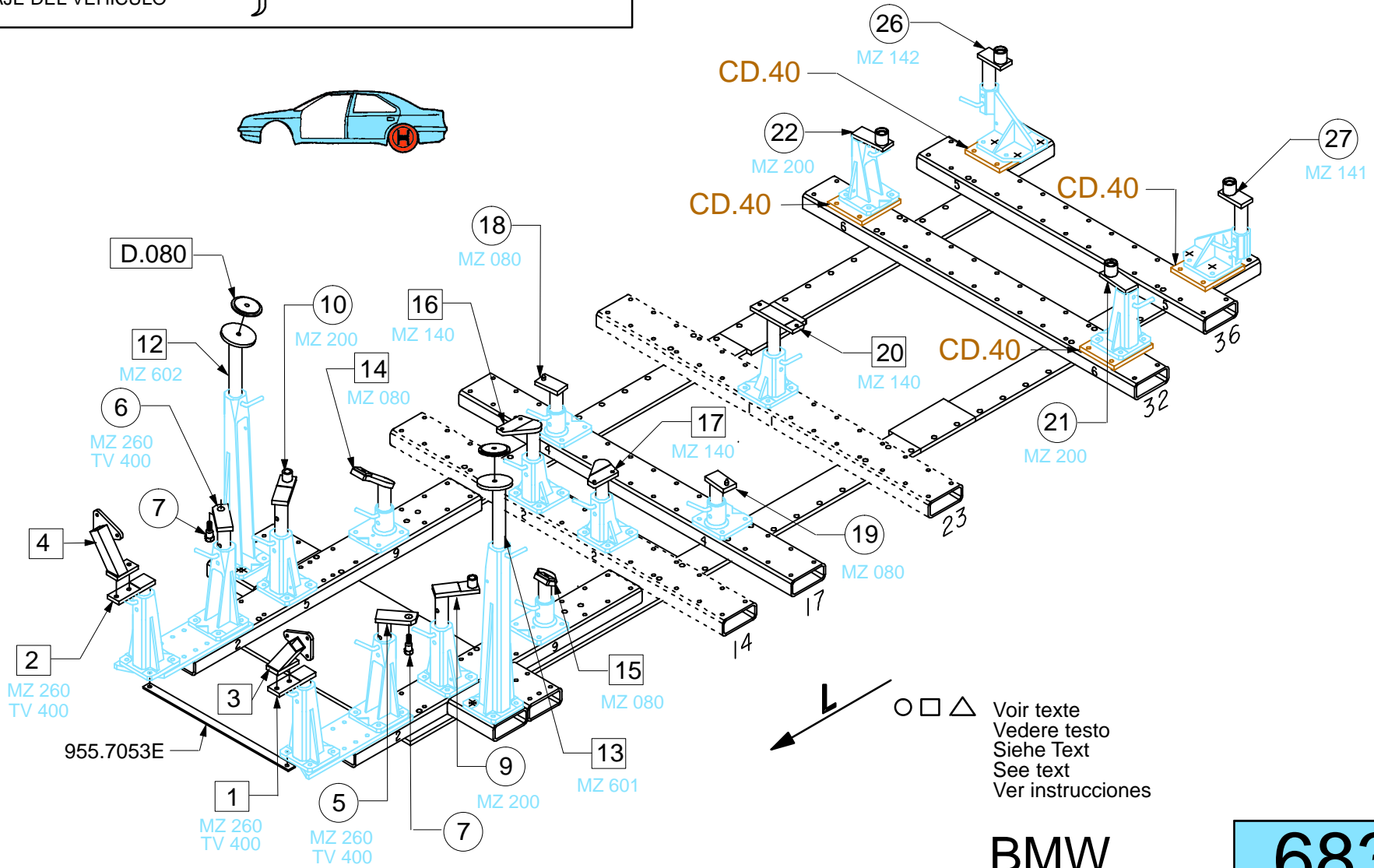

BMW

683.309

40 Kg 05.09.94 406-D-13F

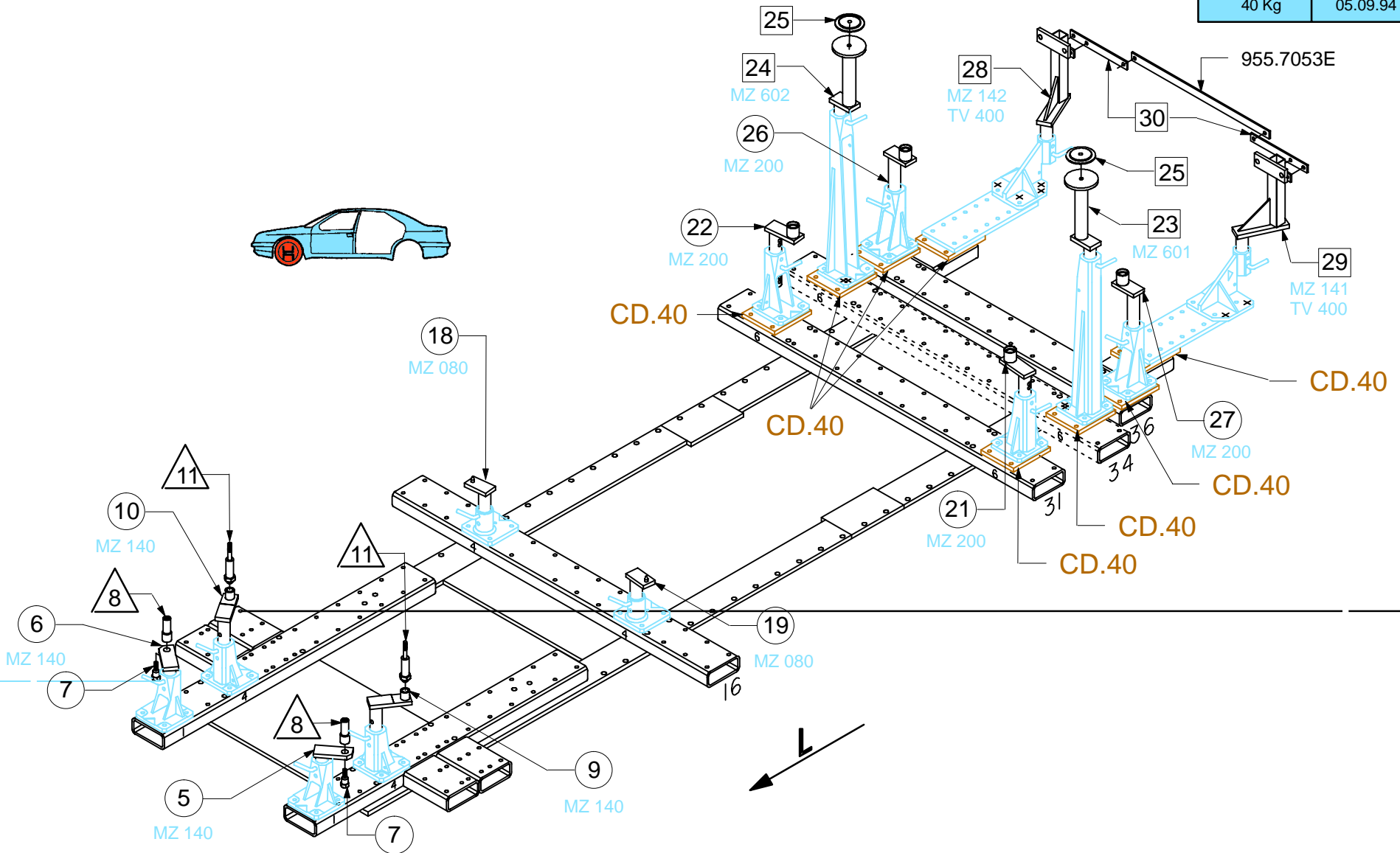

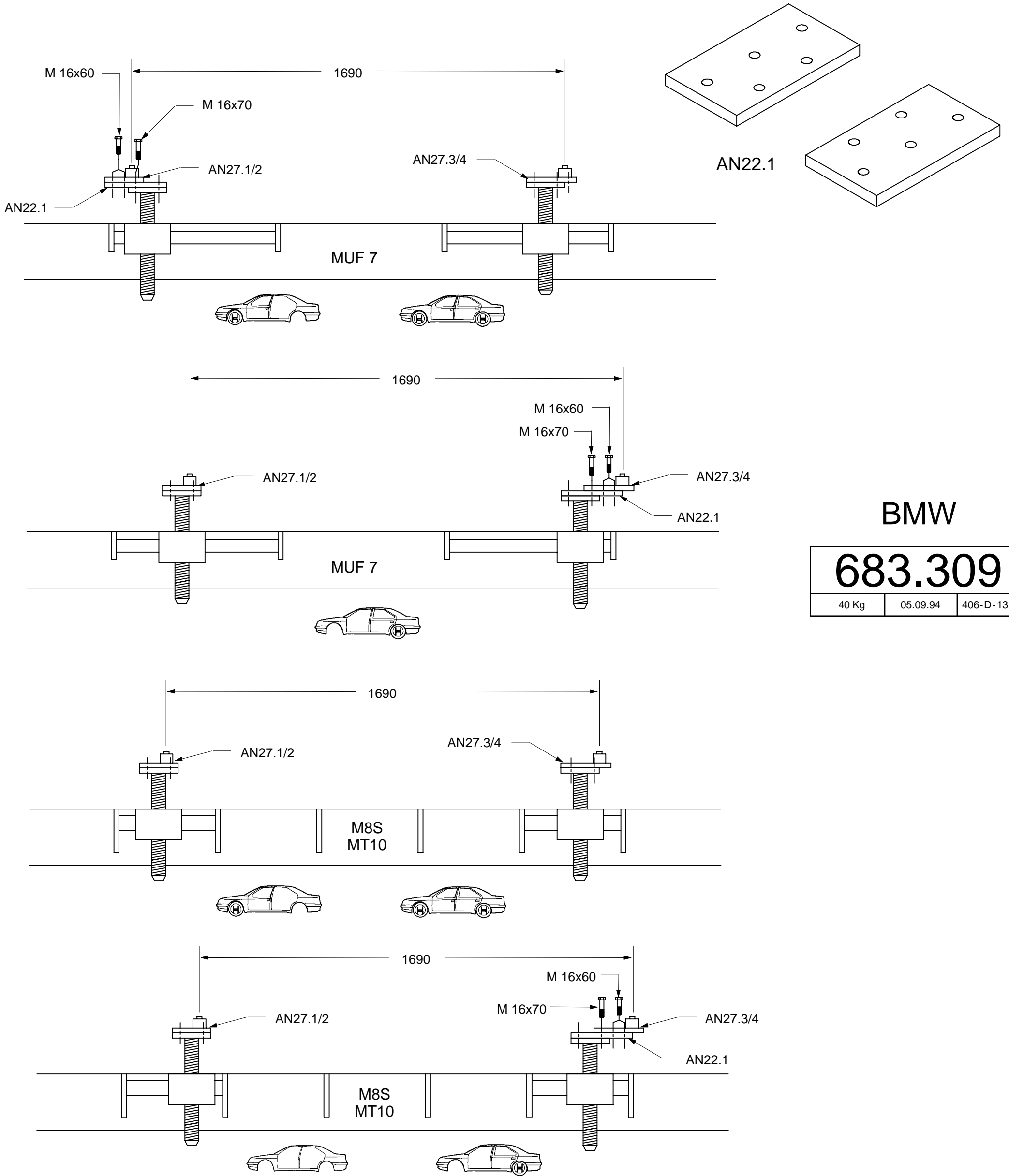

BMW

683.309

40 Kg	05.09.94	406-D-13G
-------	----------	-----------