

CITROEN / PEUGEOT / FIAT

REP.	REFERENCE	PDS	NB	MZ
1	681.701	2,9	1	141
2	681.702	2,9	1	142
3	681.703	2,9	1	260
4	681.704	3,2	1	260
5	681.705	2,0	1	260
6	681.706	2,0	1	260
7	681.707	2,8	1	
8	681.708	2,8	1	
9	681.709	2,1	1	601
10	681.710	2,1	1	602
11	681.711	1,5	2	
12	681.712	0,03	2	
13	681.713	2,8	1	140
14	681.714	2,8	1	140
15	681.715	0,06	2	
16	681.716	3,5	1	080
17	681.717	3,5	1	080
18	681.718	3,6	1	080/200
19	681.719	3,6	1	080/200
20	681.720	1,2	2	
21	681.721	0,5	2	
22	681.722	0,1	2	
23	681.723	2,6	1	200
24	681.724	2,6	1	200
25	681.725	3,0	1	140
26	681.726	3,0	1	140
27	681.727	1,6	1	
28	681.728	1,6	1	
	V.15	0,1	2	
	V.32	0,1	2	

⌘	M 10x16	6
⌘	M 10.125x30	4
⌘	M 12x25	4
⌘	M 12.125x60	2
⌘	M 12.125x100	2
⌘	M 14.150x25	2
⌘	M 14.150x30	6
⌘	M 14.150x45	6
⌘	M 16.150x30	2
⌘	M 16.150x60	4
⌘	M 16.150x70	4
⌘	M 12	2
⌘	M 12	2

681.300

69 Kg 12.01.96 408-D-13A

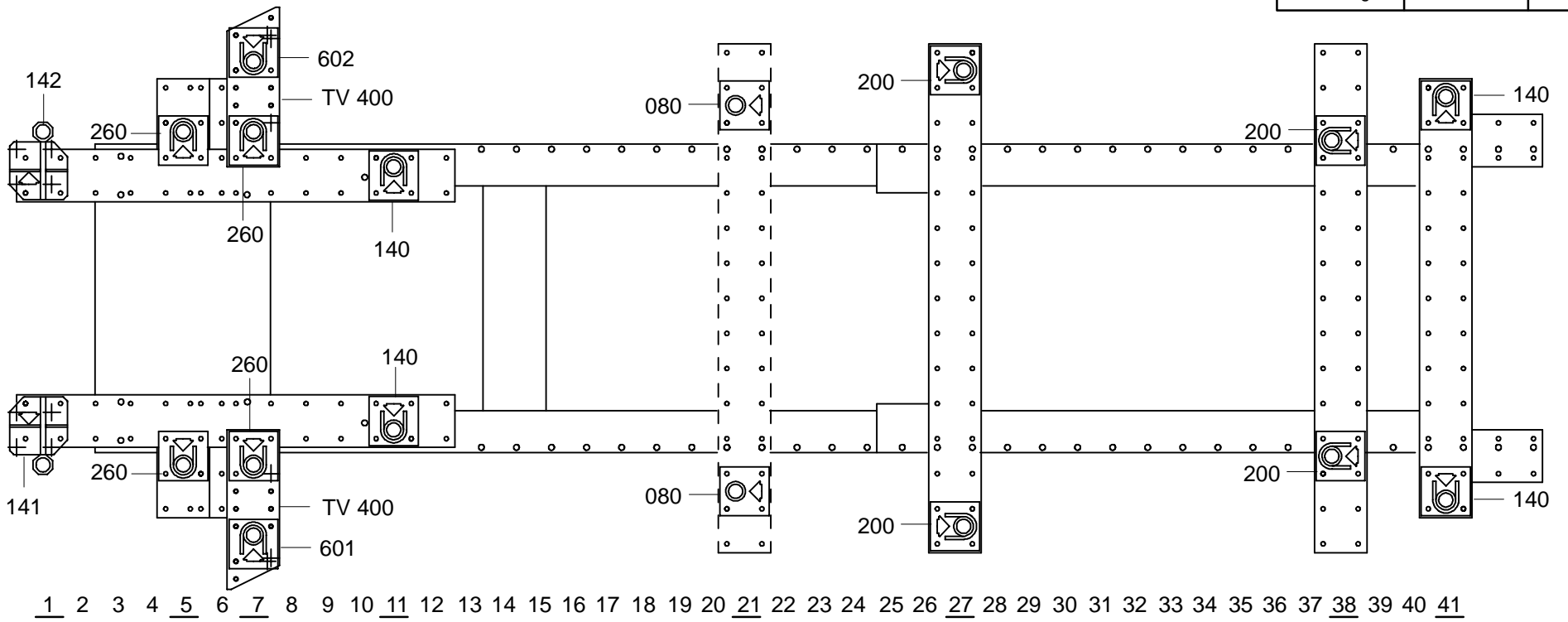

1 2 3 4 5 6 7 8 9 10 11 12 13 14 15 16 17 18 19 20 21 22 23 24 25 26 27 28 29 30 31 32 33 34 35 36 37 38 39 40 41

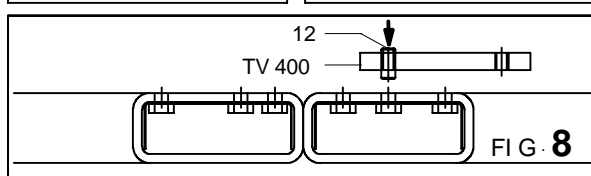
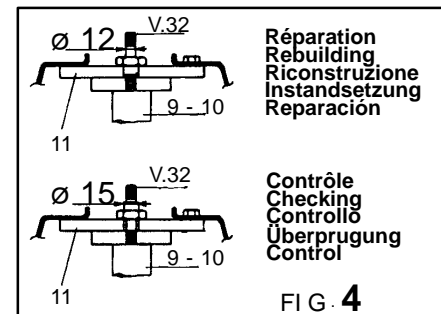
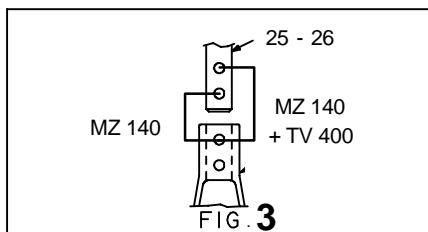
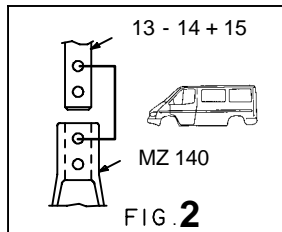
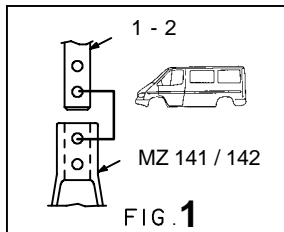

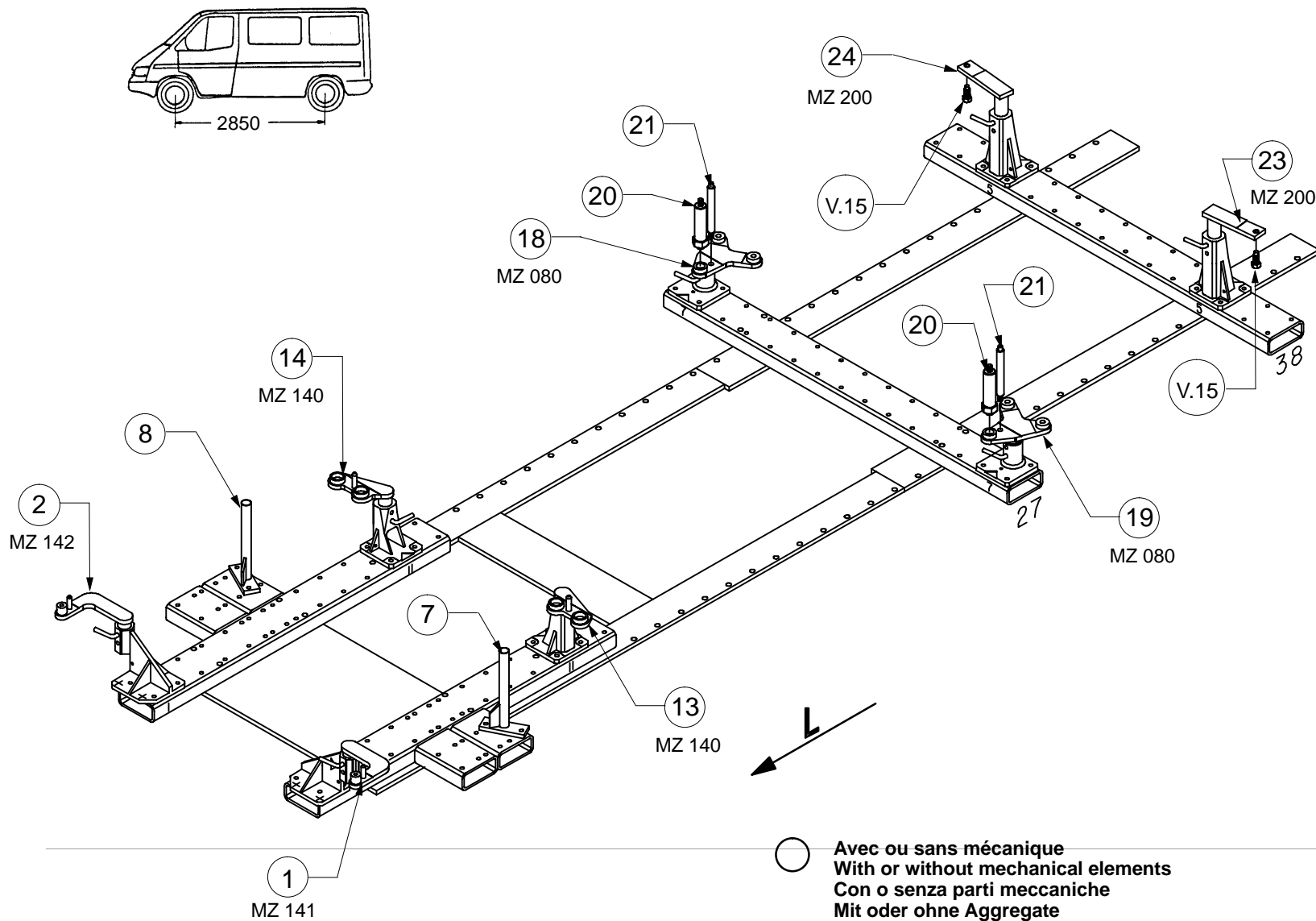

CITROEN / PEUGEOT / FIAT

681.300

69 Kg | 12.01.96 | 408-D-13B

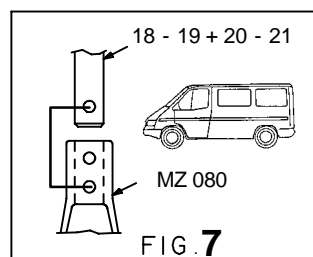
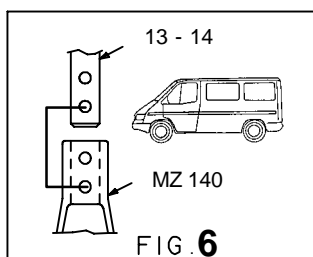
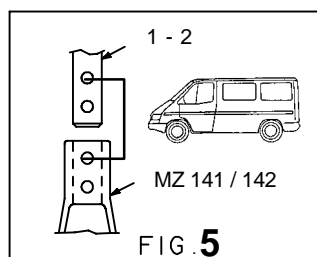
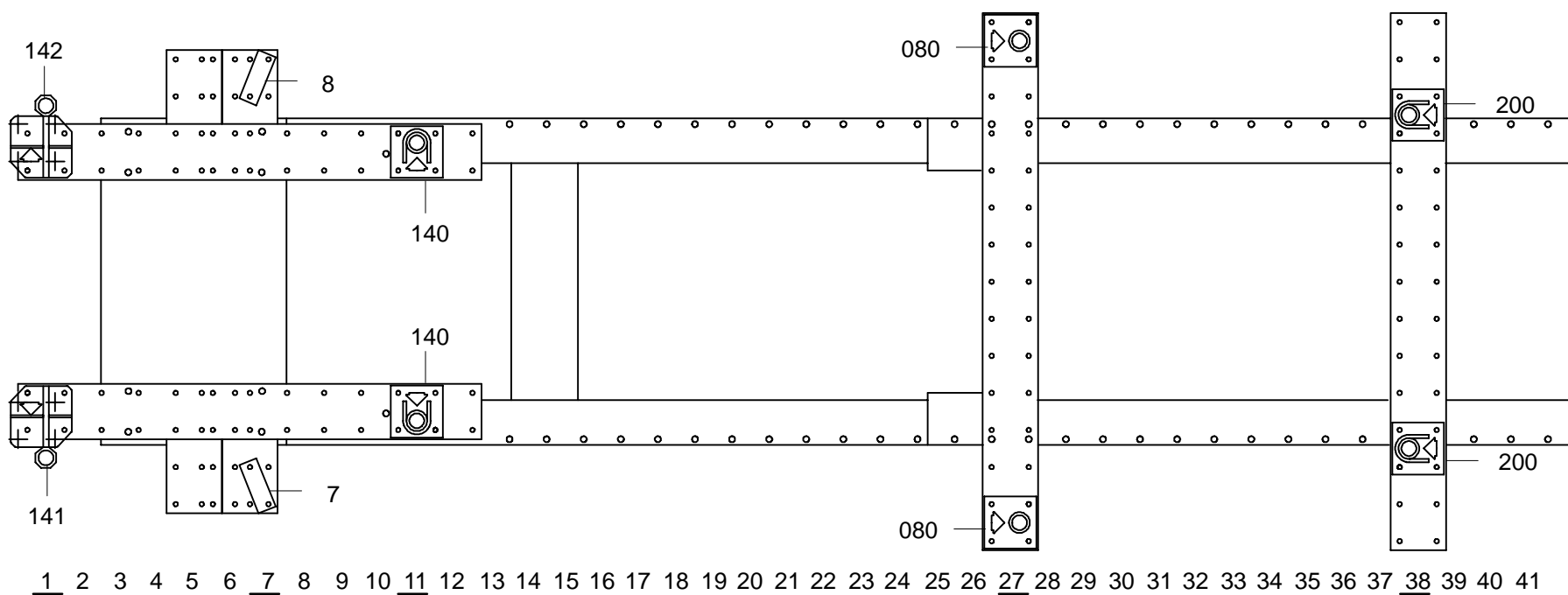

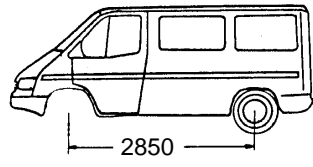
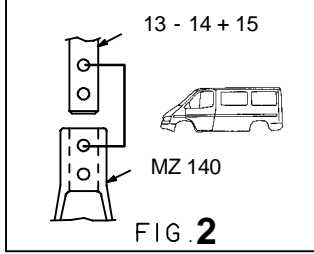
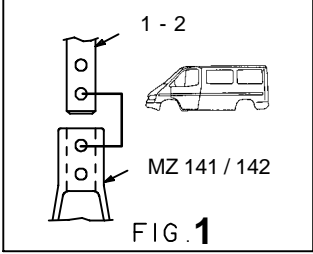

CHOC AVANT
FRONT DAMAGE
VORBAUREPARATUR
URTO ANTERIORE
CHOQUE DELANTERO

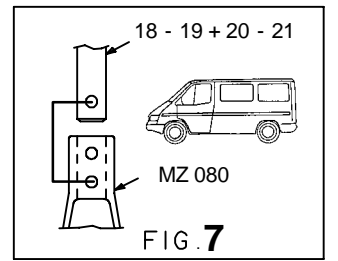
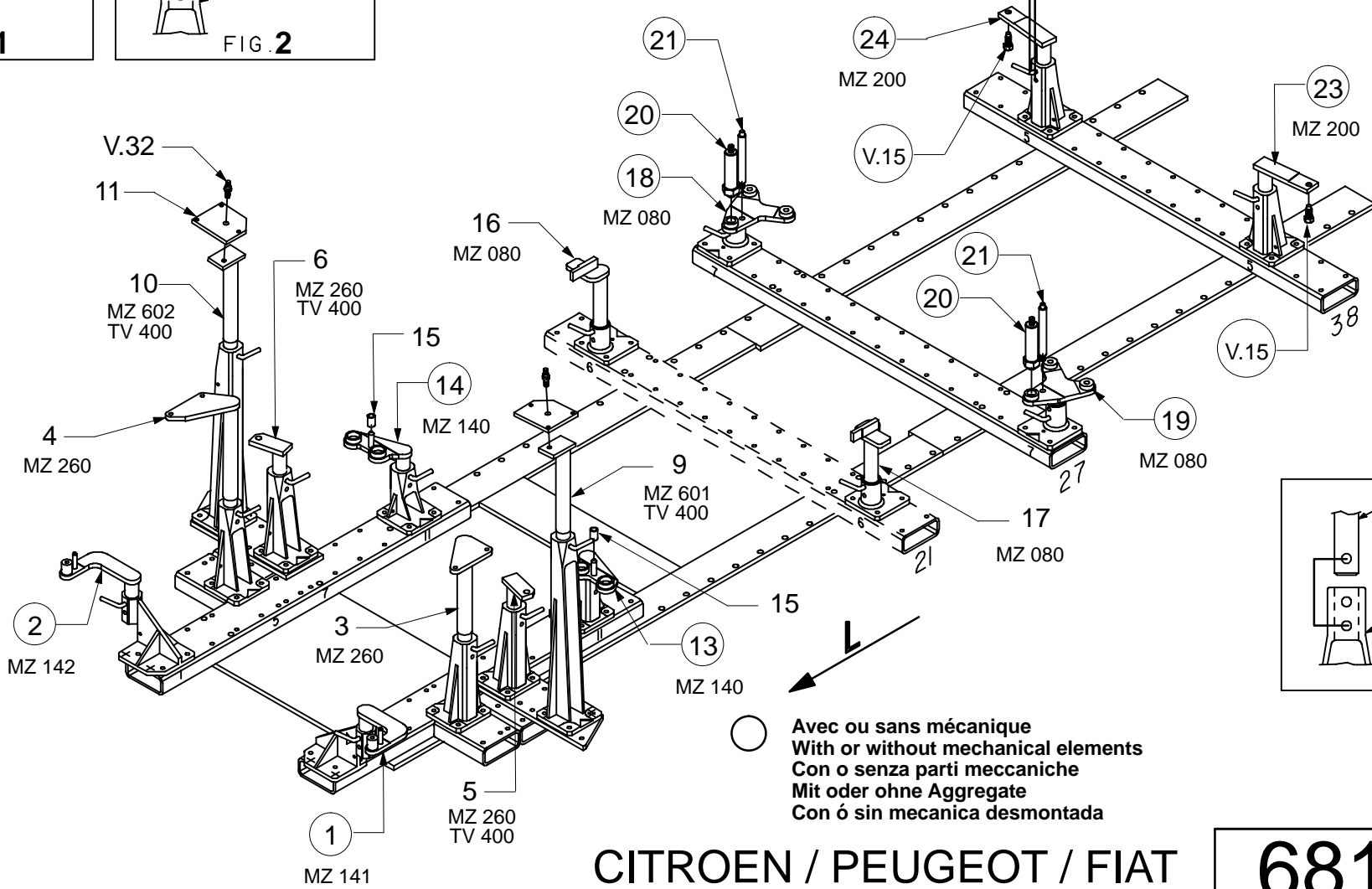

CITROEN / PEUGEOT / FIAT

681.300

69 Kg | 12.01.96 | 408-D-13C

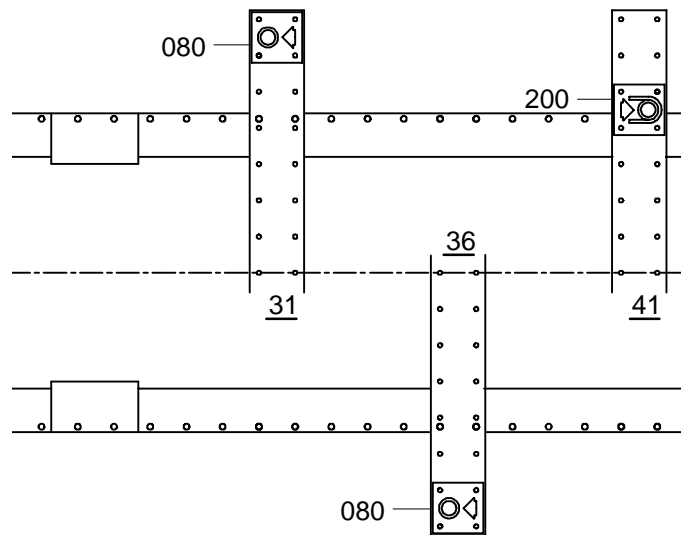
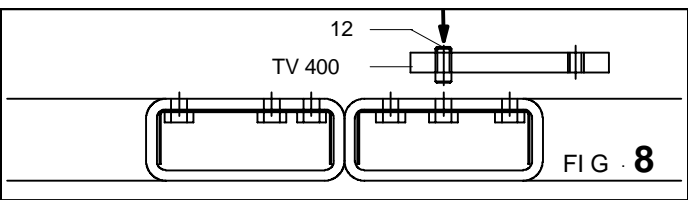
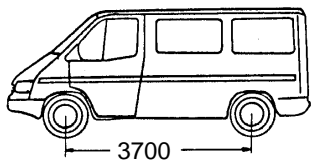
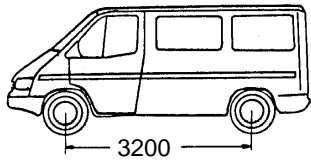
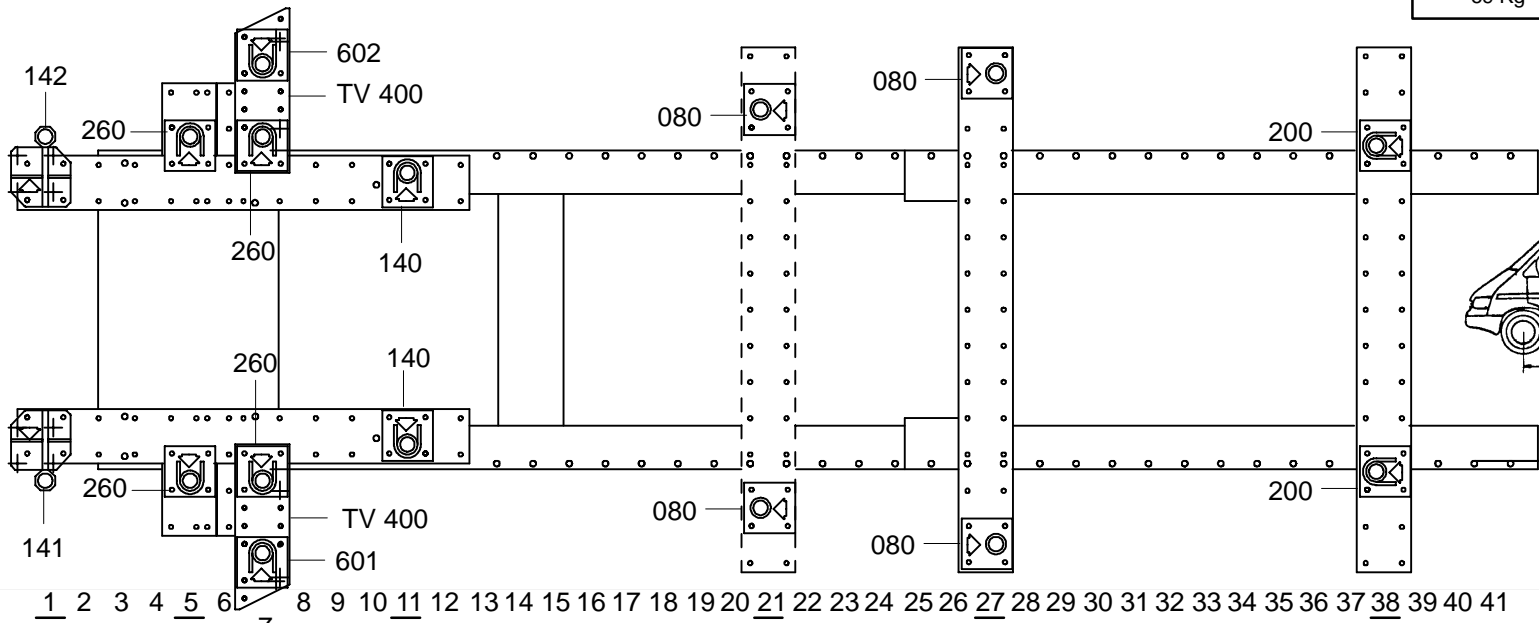

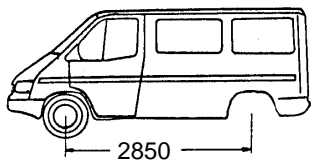

CHOC ARRIERE
REAR DAMAGE
HECKREPARATUR
URTO POSTERIORE
CHOQUE TRASERO

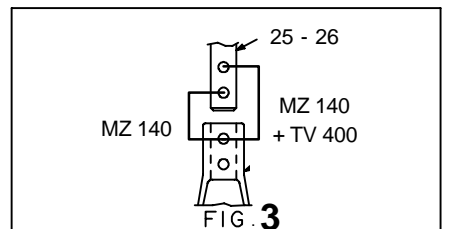
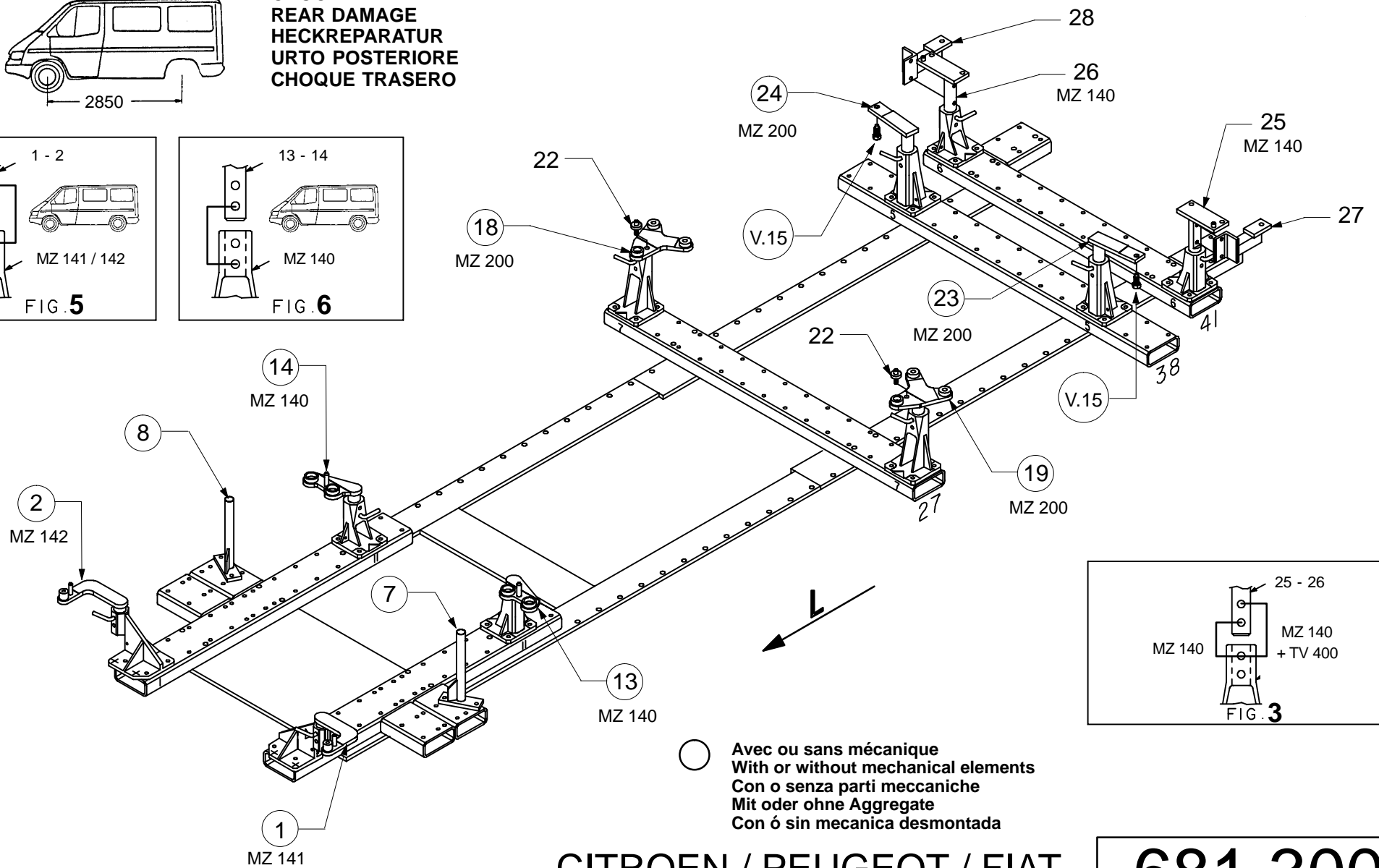
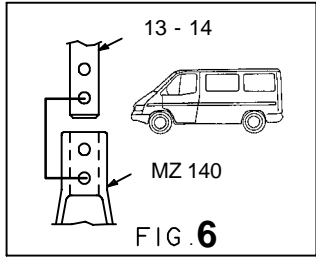
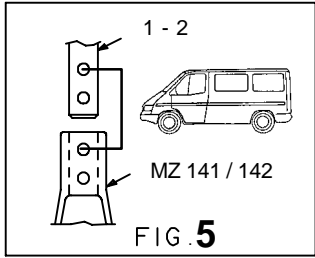

CITROEN / PEUGEOT / FIAT

681.300

69 Kg | 12.01.96 | 408-D-13D

