

REP.	REFERENCE	PDS	NB	MZ
1	678.701	3,3	1	260
2	678.702	3,3	1	260
3	678.703	0,1	6	
4	678.704	0,2	6	
5	678.705	2,8	1	080
6	678.706	2,8	1	080
7	678.707	2,8	1	140
8	678.708	2,8	1	140
9	678.709	2,9	1	200
10	678.710	2,9	1	200
11	678.711	0,04	2	
12	678.712	2,9	1	080
13	678.713	2,9	1	080
14	678.714	2,5	1	080
15	678.715	2,5	1	080
16	678.716	4,3	1	080
17	678.717	4,3	1	080
18	678.718	0,2	2	
19	678.719	3,0	1	140
20	678.720	3,0	1	140
21	678.721	2,4	1	142
22	678.722	2,4	1	141
23	678.723	1,5	1	140
24	678.724	1,5	1	140
25	678.725	0,6	2	
26	678.726	1,2	2	
27	678.727	2,5	1	260
28	678.728	2,6	1	260
29	678.729	2,6	1	260
33	678.733	0,2	2	
40	678.740	0,2	8	
	B.12	0,2	4	

	M 8x30	4
	M 10x60	4
	M 12.125x25	2
	M 12x25	2
	M 14x40	2
	L 14	2
	M 10	4
	M 14	6

○ Avec ou sans mécanique
With or without mechanical elements
Con o senza parti meccaniche
Mit oder ohne Aggregate
Con ó sin mecanica desmontada

TOYOTA

678.300

74 Kg 23.03.95 434-D-46A

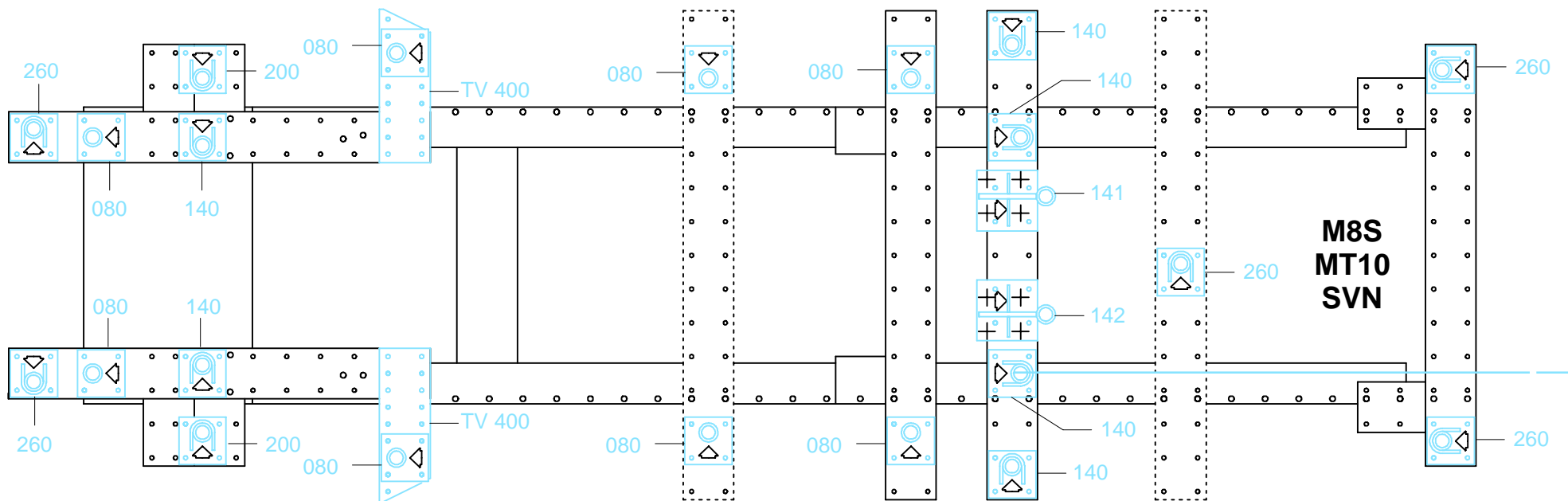

1 2 3 4 5 6 7 8 9 10 11 12 13 14 15 16 17 18 19 20 21 22 23 24 25 26 27 28 29 30 31 32 33 34 35 36 37 38 39 40 41

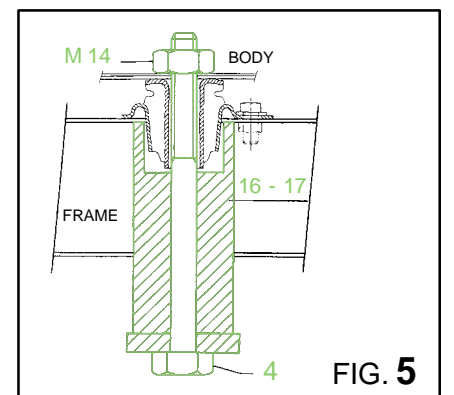
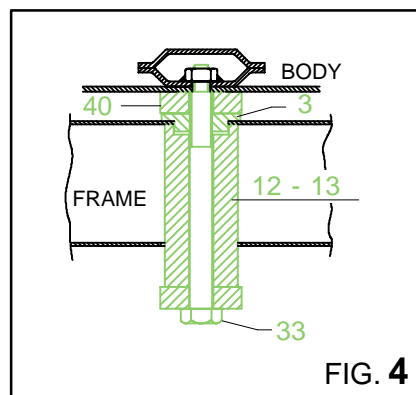
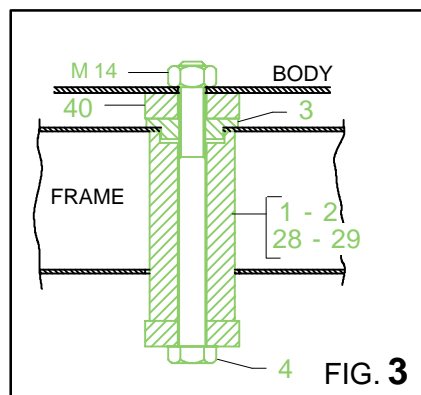
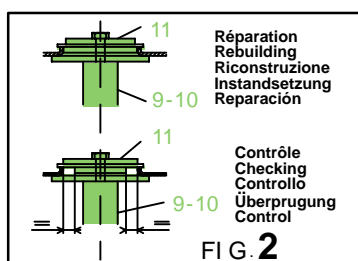
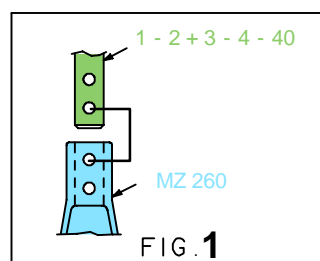



**M8S
MT10
SVN**

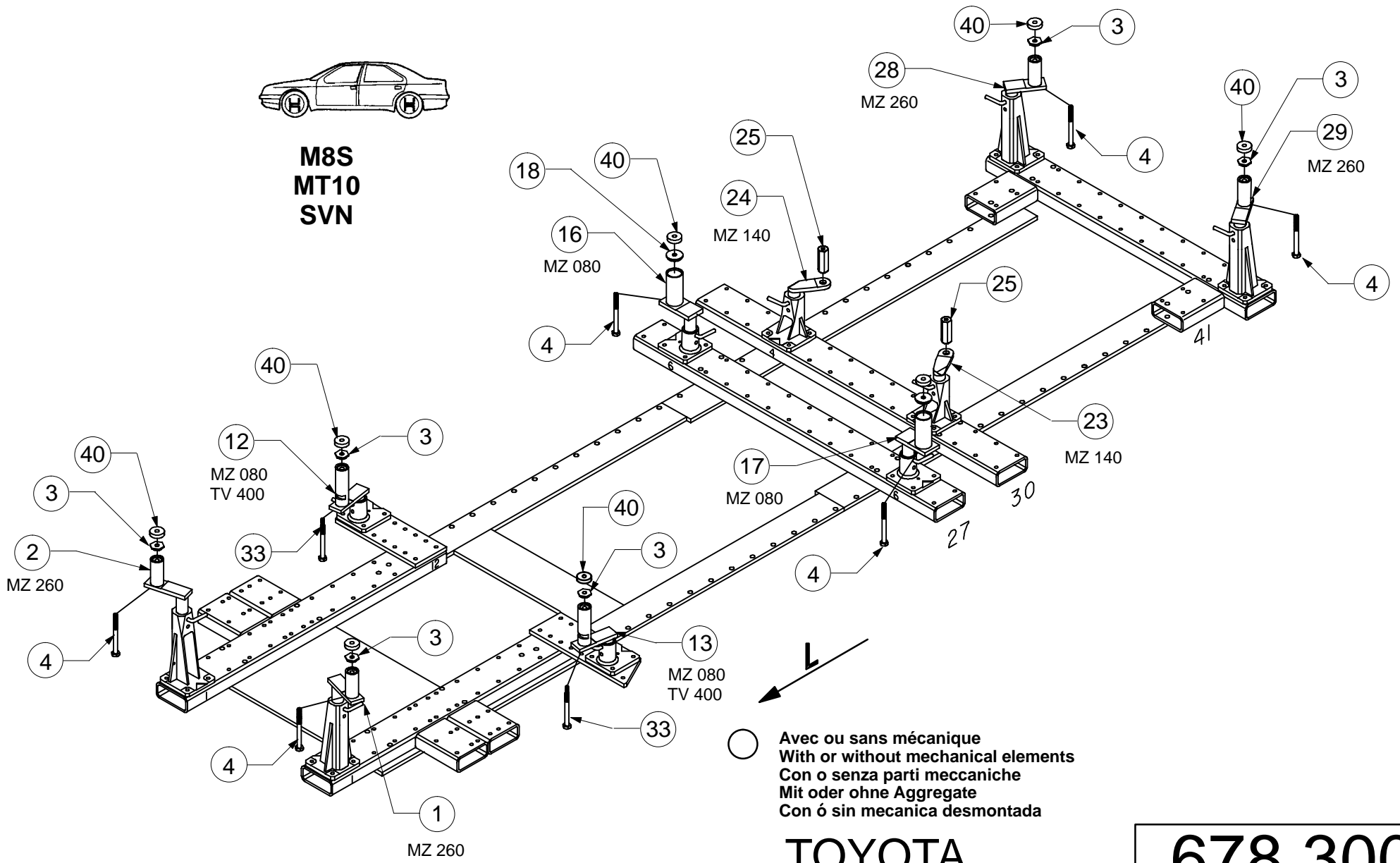

TOYOTA

678.300

74 Kg 23.03.95 434-D-46B

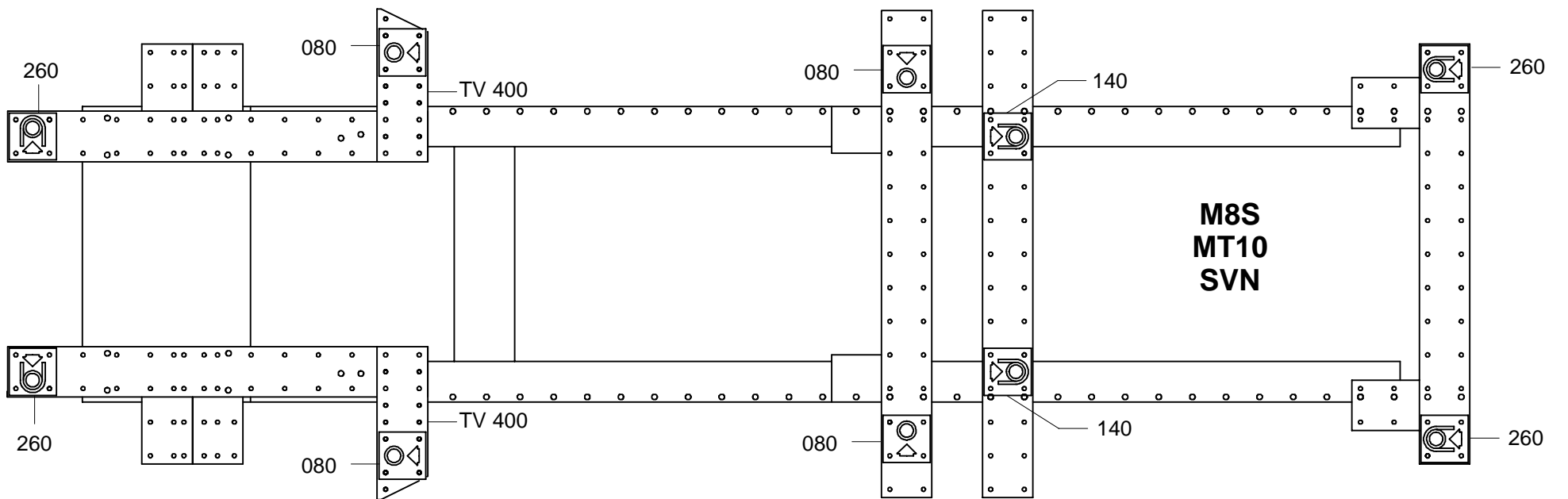

1 2 3 4 5 6 7 8 9 10 11 12 13 14 15 16 17 18 19 20 21 22 23 24 25 26 27 28 29 30 31 32 33 34 35 36 37 38 39 40 41

