

| REP. | REFERENCE | PDS | NB | MZ |
|------|-----------|-----|----|-----|
| 1 | 658.701 | 2,6 | 1 | 142 |
| 2 | 658.702 | 2,6 | 1 | 141 |
| 3 | 658.703 | 1,1 | 1 | |
| 4 | 658.704 | 1,1 | 1 | |
| 5 | 658.705 | 1,9 | 1 | 260 |
| 6 | 658.706 | 1,9 | 1 | 260 |
| 7 | 658.707 | 3,6 | 1 | 260 |
| 8 | 658.708 | 3,6 | 1 | 260 |
| 9 | 658.709 | 0,7 | 2 | |
| 10 | 658.710 | 3,2 | 1 | 200 |
| 11 | 658.711 | 3,2 | 1 | 200 |
| 12 | 658.712 | 2,6 | 1 | 200 |
| 13 | 658.713 | 2,6 | 1 | 200 |
| 14 | 658.714 | 3,4 | 1 | 140 |
| 15 | 658.715 | 3,4 | 1 | 140 |
| 16 | 658.716 | 1,1 | 1 | |
| 17 | 658.717 | 1,1 | 1 | |
| 18 | 658.718 | 5,6 | 1 | 140 |
| 19 | 658.719 | 5,6 | 1 | 140 |
| | V.32 | 0,1 | 2 | |
| | E.23 | 0,1 | 2 | |
| | E.07 | 0,1 | 2 | |
| | B.84 | 1,1 | 2 | |

| | | |
|--|----------|----|
| | M 10x30 | 2 |
| | M 12x30 | 14 |
| | M 12x90 | 2 |
| | M 12x110 | 2 |
| | M 12x150 | 2 |

| | | |
|--|------|---|
| | M 12 | 6 |
|--|------|---|

○ Avec ou sans mécanique
 With or without mechanical elements
 Con o senza parti meccaniche
 Mit oder ohne Aggregate
 Con ó sin mecanica desmontada

FORD

658.300

55 Kg 19.03.93 412-D-18A

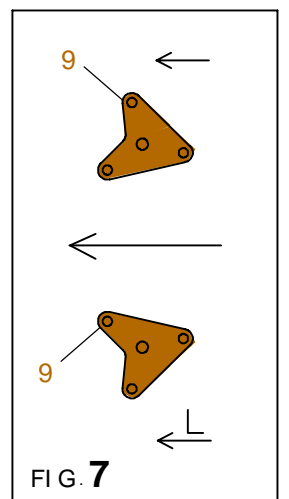
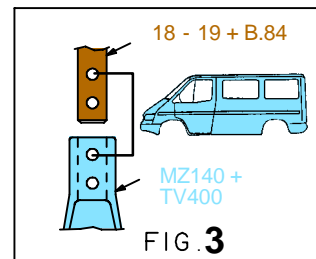
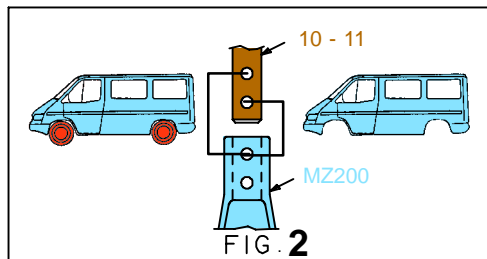
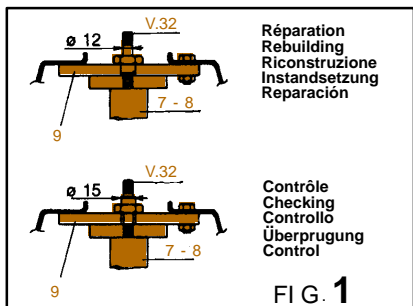
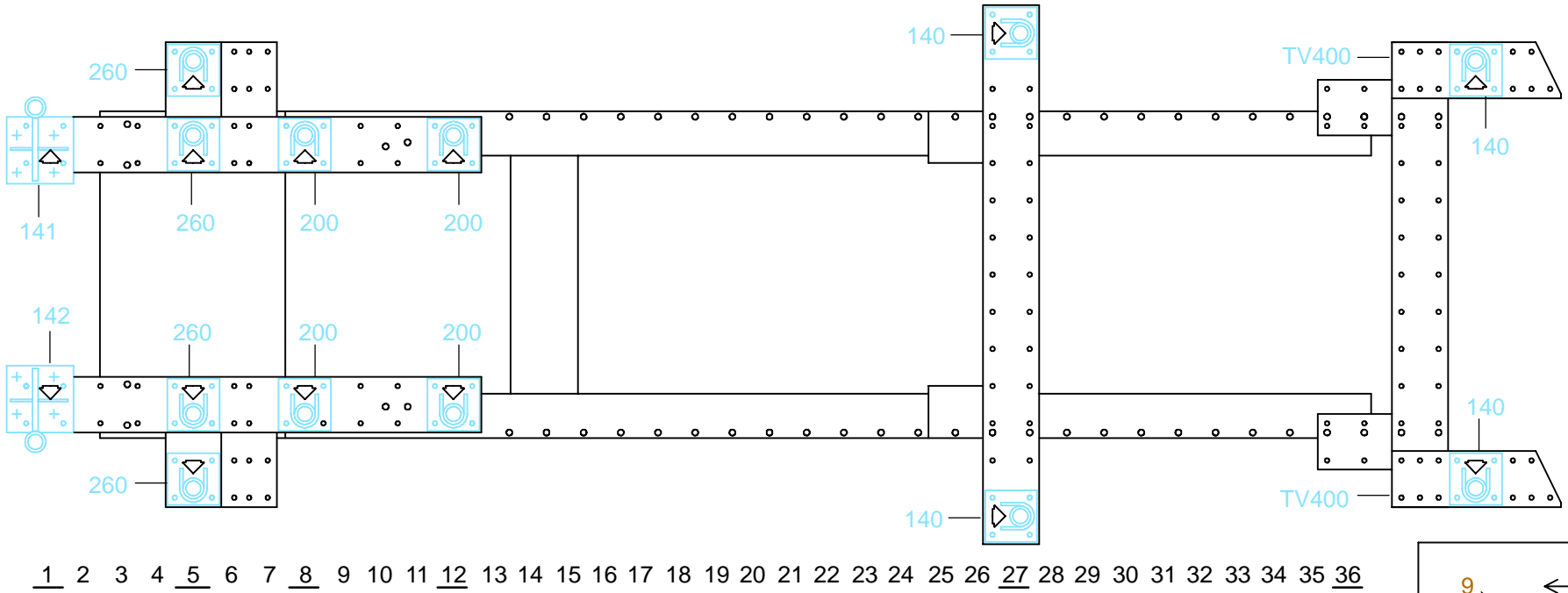

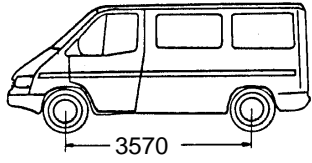

**CHOC AVANT
FRONT DAMAGE
VORBAUREPARATUR
URTO ANTERIORE
CHOQUE DELANTERO**

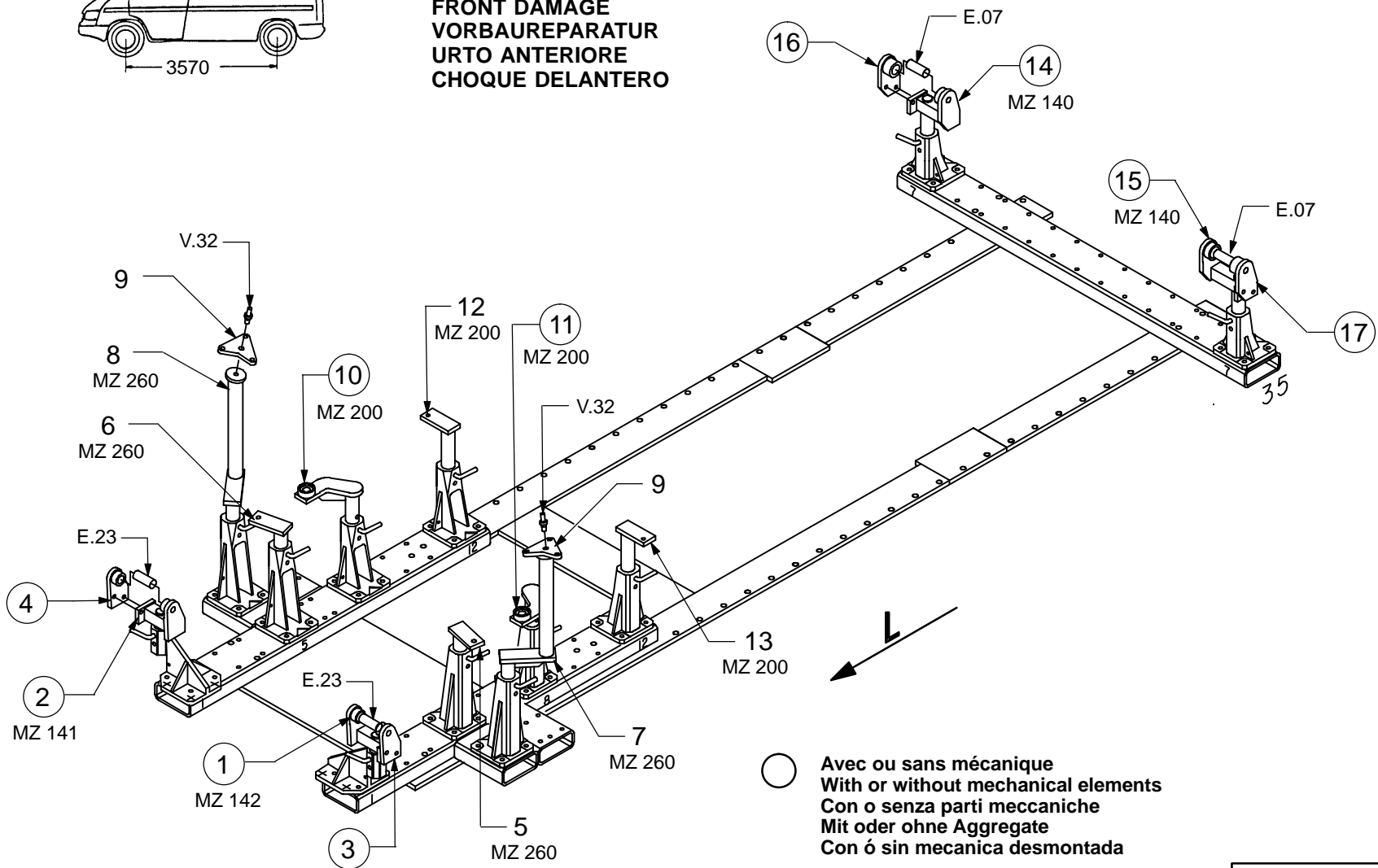

FORD

658.300

55 Kg 19.03.93 412-D-18B

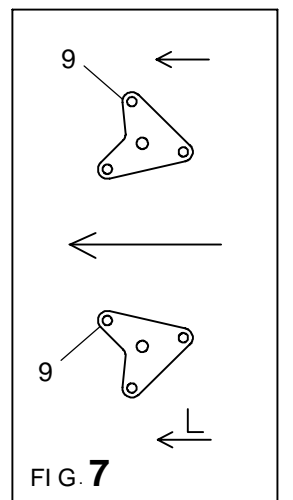
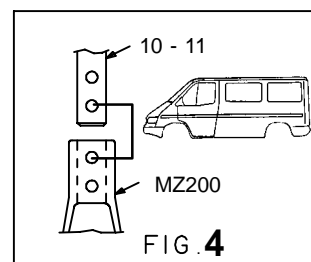
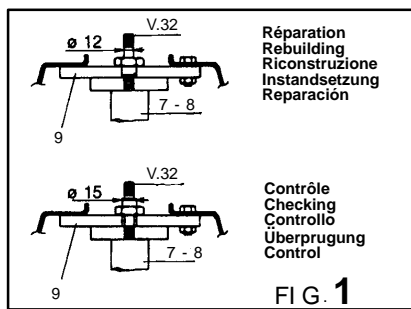
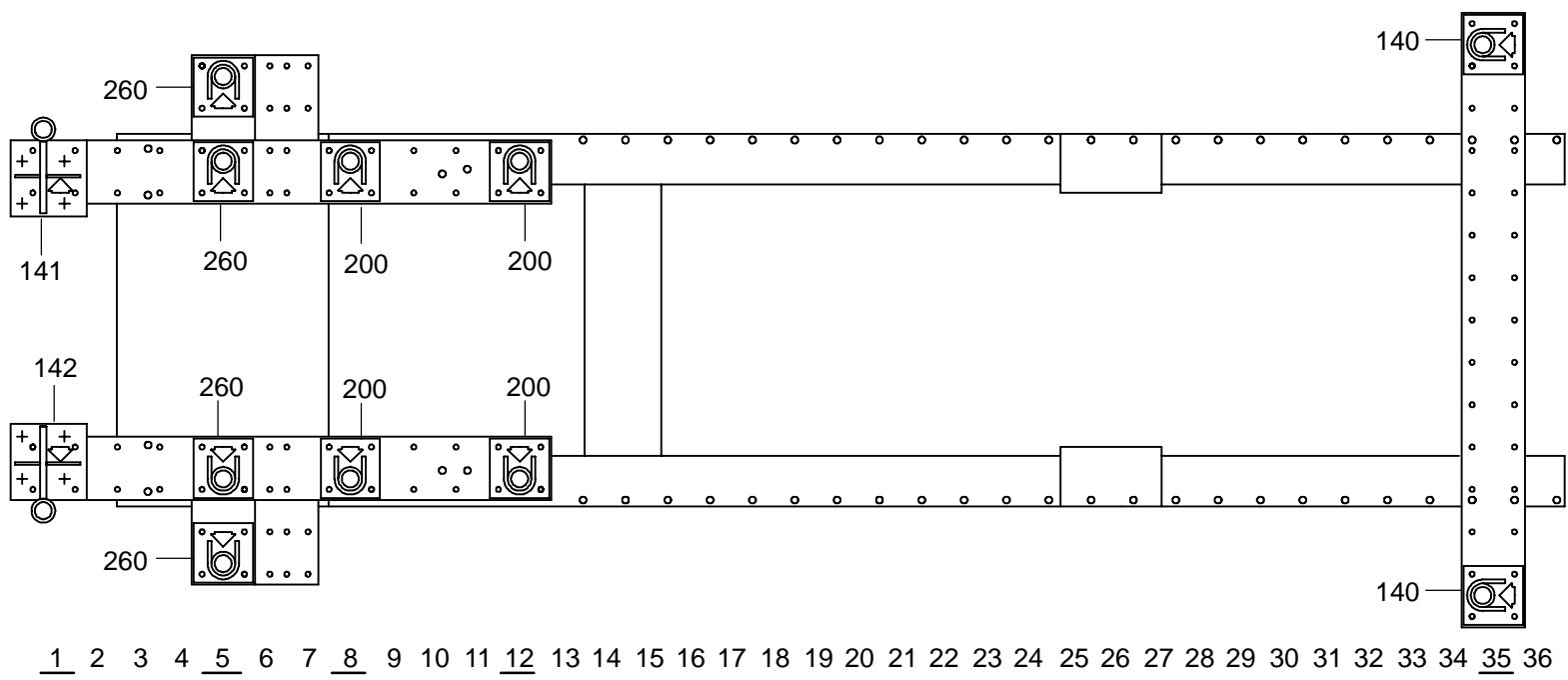

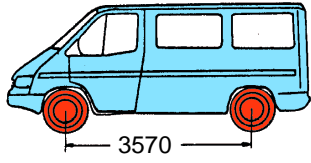

CHOC ARRIERE
REAR DAMAGE
HECKREPARATUR
URTO POSTERIORE
CHOQUE TRASERO

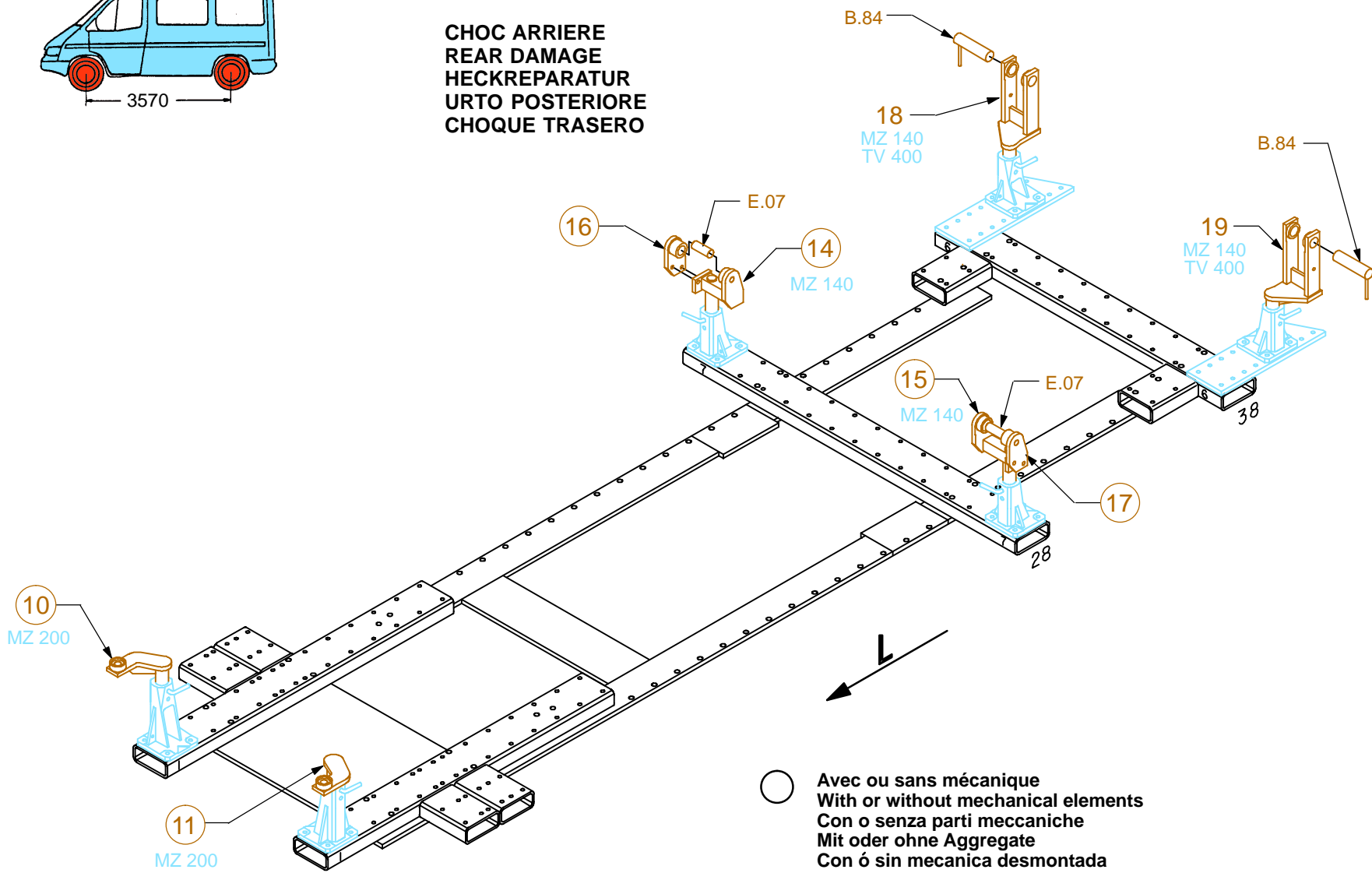

FORD

658.300

55 Kg 22.09.92 412-D-18C

