

REP.	REFERENCE	PDS	NB	MZ
77	642.777	4,2	1	260
78	642.778	4,2	1	260
79	642.779	2,3	1	080
80	642.780	2,3	1	080
81	642.781	2,8	1	080/140
82	642.782	2,8	1	080/140
83	642.783	2,8	1	601
84	642.784	2,8	1	602
85	642.785	0,7	2	

M 14.150x120  
 M 14.150x180

4  
 2

complément au  
 complementary set to  
 complemento al  
 zusatz zu

**642.300 +**  
**642.306**

**HONDA**

**642.304**

26 Kg    07.02.97    413-D-19L

Avec ou sans mécanique  
 With or without mechanical elements  
 Con o senza parti meccaniche  
 Mit oder ohne Aggregate  
 Con ó sin mecanica desmontada

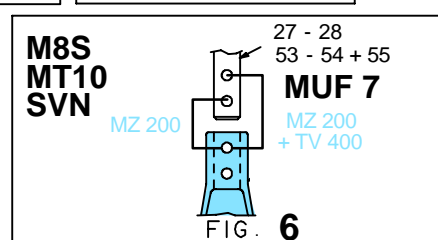
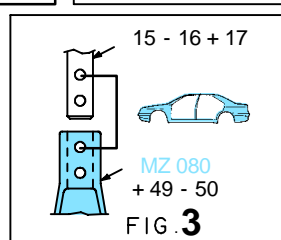
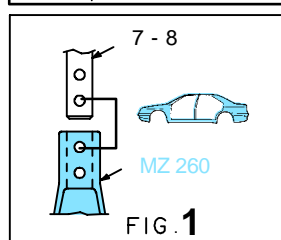
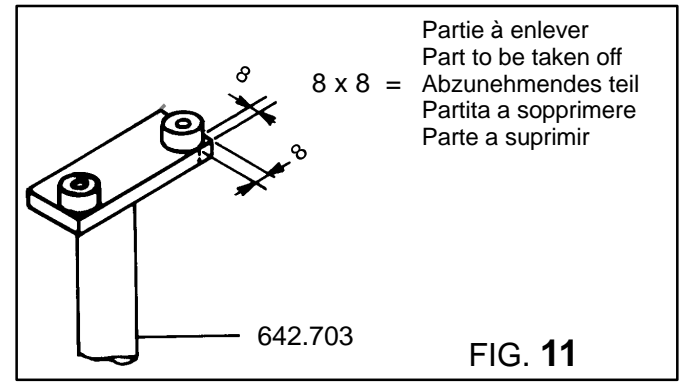
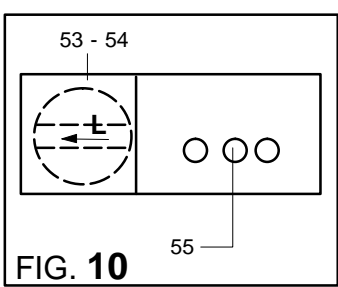
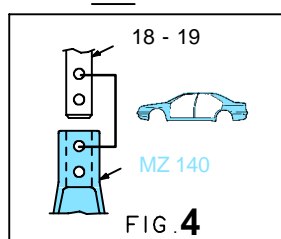
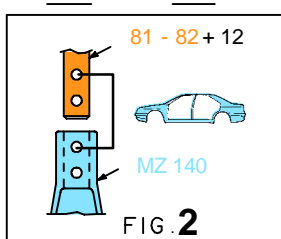
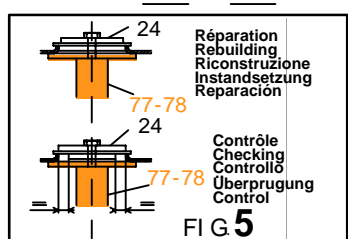
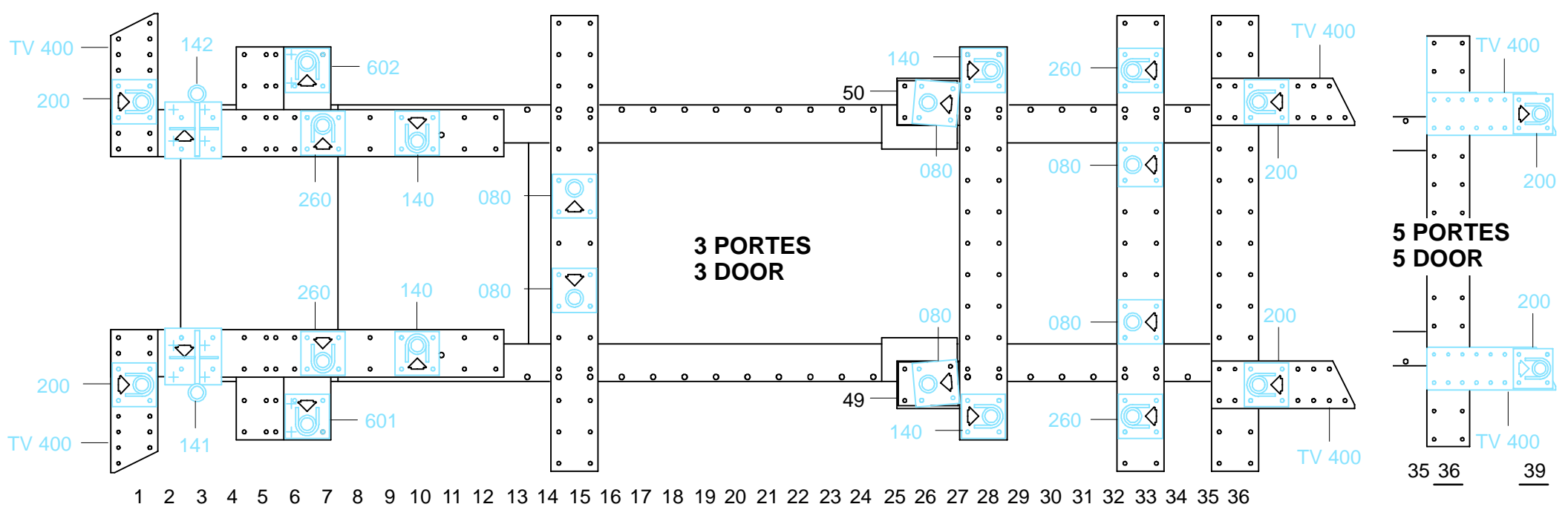

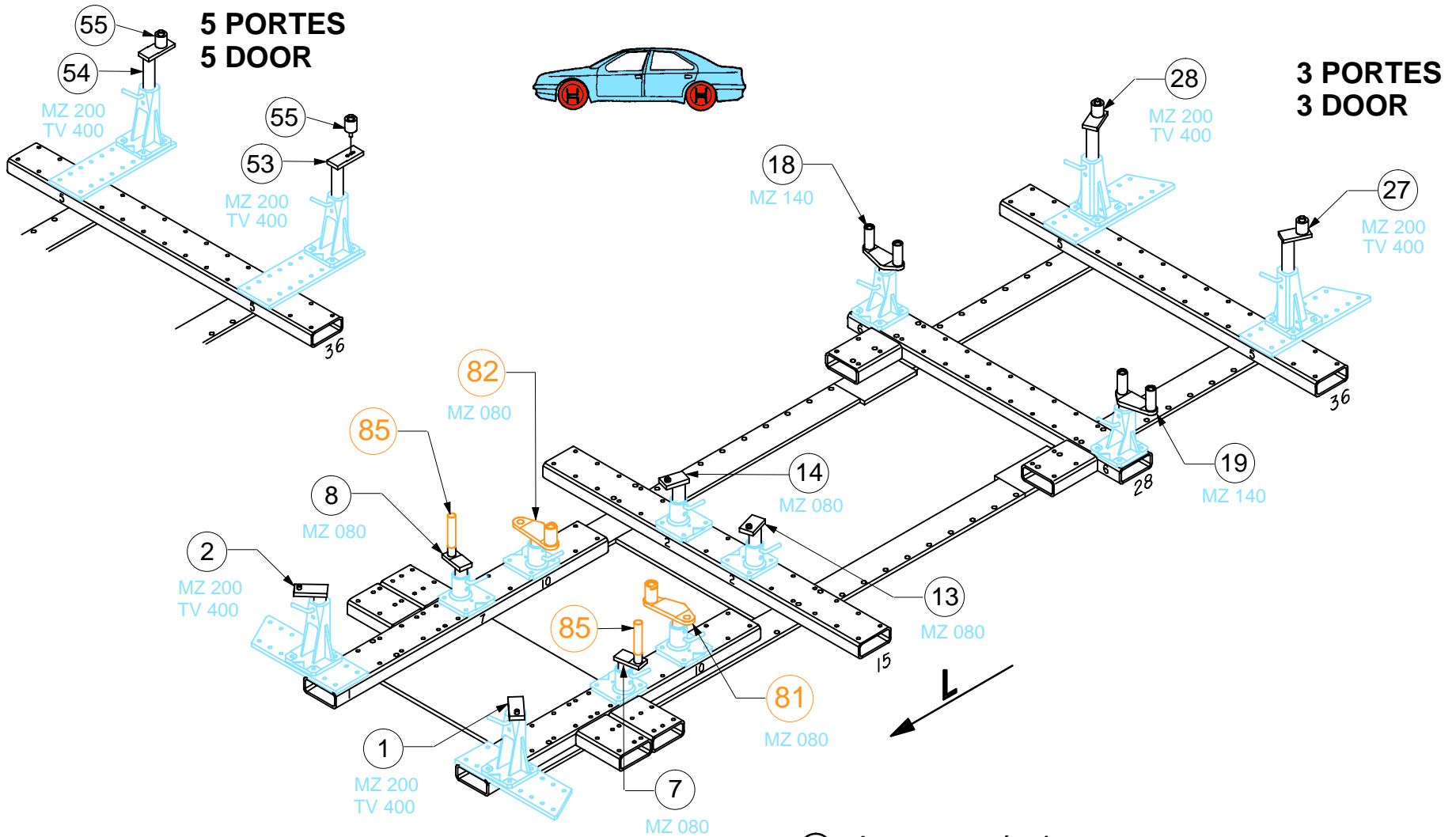

○ Avec ou sans mécanique  
With or without mechanical elements  
Con o senza parti meccaniche  
Mit oder ohne Aggregate  
Con ó sin mecanica desmontada

**HONDA**

**642.304**

26 Kg | 07.02.97 | 413-D-19M

