

10/

Réparation
Rebuilding
Riconstruzione
Instandsetzung
Reparación

Contrôle
Checking
Controllo
Überprüfung
Control

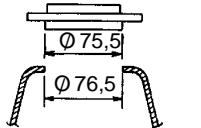

Tolérance ± 0,5
Tolerance
Toleranz
Tolleranza
Tolerancia

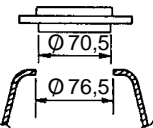

Tolérance ± 3
Tolerance
Toleranz
Tolleranza
Tolerancia

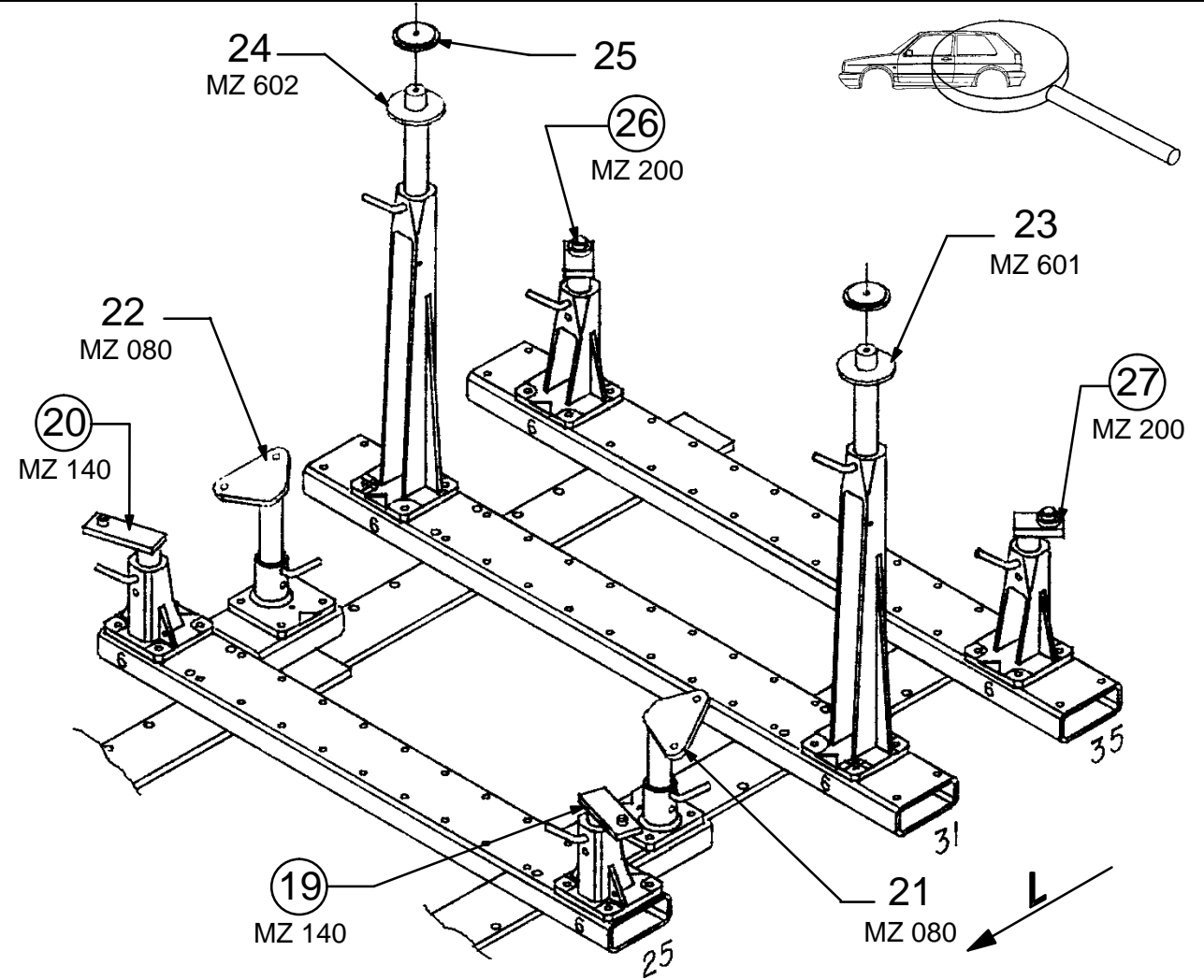
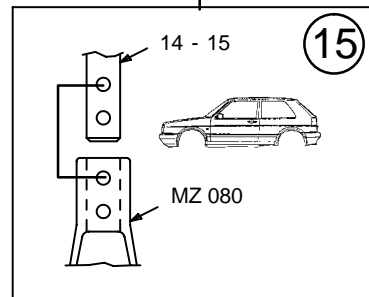
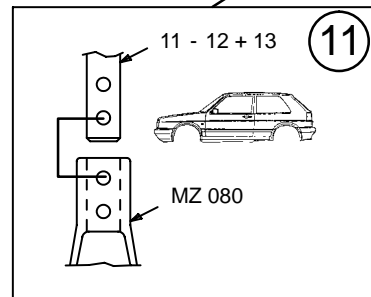
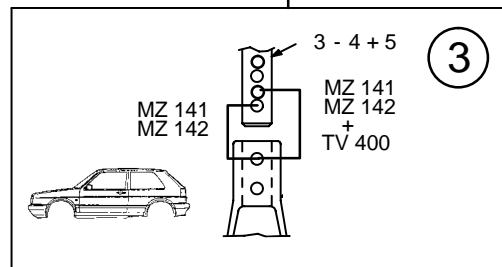
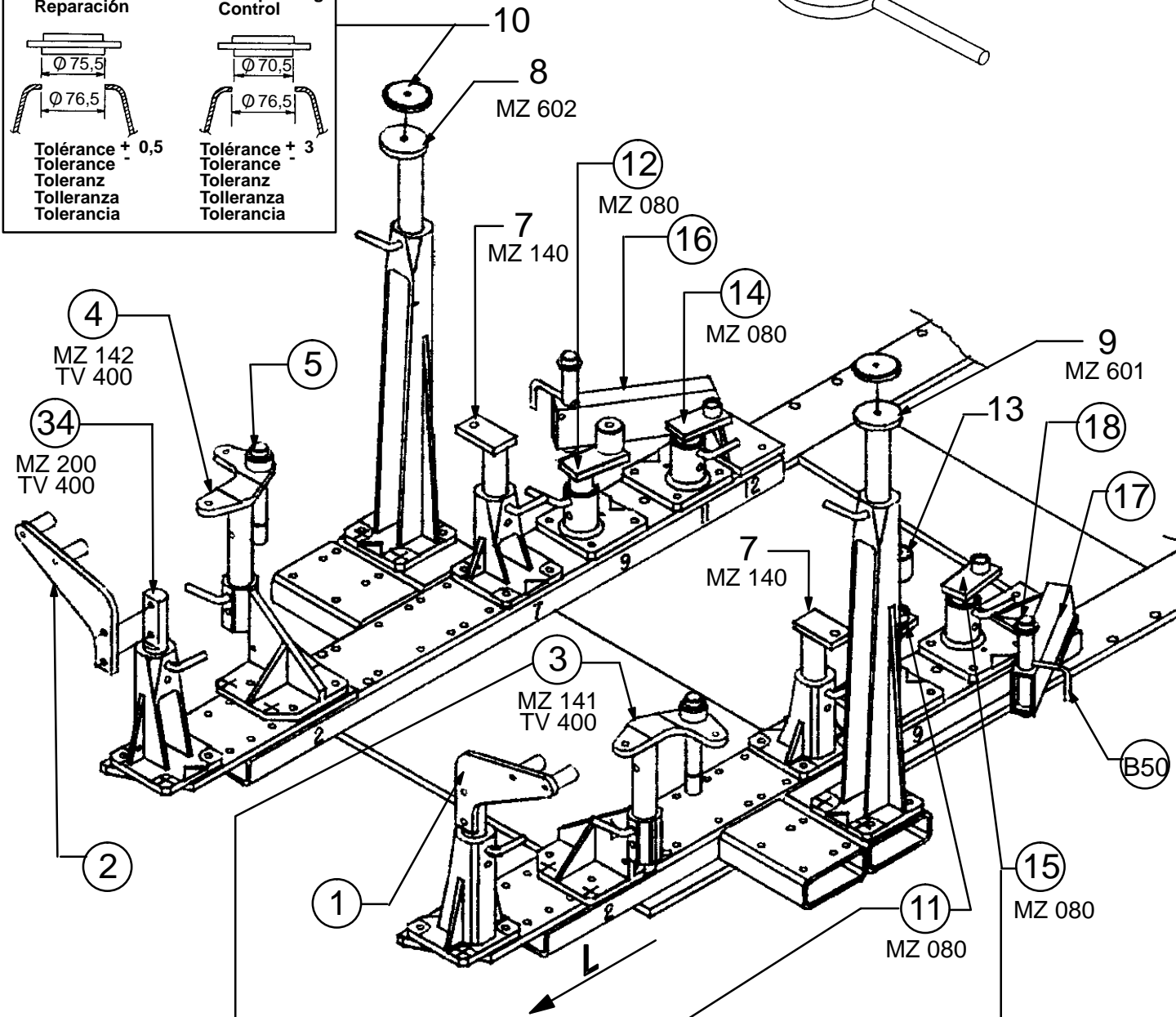
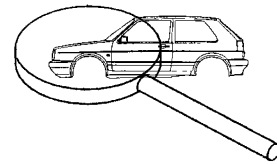

REP.	REFERENCE	PDS	NB	MZ	REP.	REFERENCE	PDS	NB	MZ
1	621.701	2,3	1		26	621.726	1,7	1	200
2	621.702	2,3	1		27	621.727	1,7	1	200
3	621.703	4,0	1	141	28	621.728	3,3	1	200
4	621.704	4,0	1	142	29	621.729	3,3	1	200
5	621.705	0,8	2		30	621.730	2,3	1	200
6	621.706	1,5	2	080	34	621.734	1,6	2	200
7	621.707	2,0	2	140	35	621.735	2,4	1	200
8	621.708	2,9	1	602		B 50	0,1	2	
9	621.709	2,9	1	601					
10	621.710	0,3	2			HM 8x20		1	
11	621.711	1,5	1	080		HM 8x80		4	
12	621.712	1,5	1	080		HM 10x20		2	
13	621.713	0,7	2			HM 10x30		10	
14	621.714	1,4	1	080		HM 10x50		2	
15	621.715	1,4	1	080		HM 16x25		1	
16	621.716	4,3	1			HM 12.150x30		2	
17	621.717	4,3	1			HM 12.150x80		2	
18	621.718	0,7	2			HM 12.150x100		2	
19	621.719	1,8	1	140		HM 12x30		4	
20	621.720	1,8	1	140		HM 12x35		2	
21	621.721	3,2	1	080		HM 12x65		2	
22	621.722	3,2	1	080					
23	621.723	3,2	1	601		HM 8		1	
24	621.724	3,2	1	602		HM 12		2	
25	621.725	0,3	2			HM 16		1	

V.A.G 1740

82 Kg 438-D-11A 08.06.95

621.300

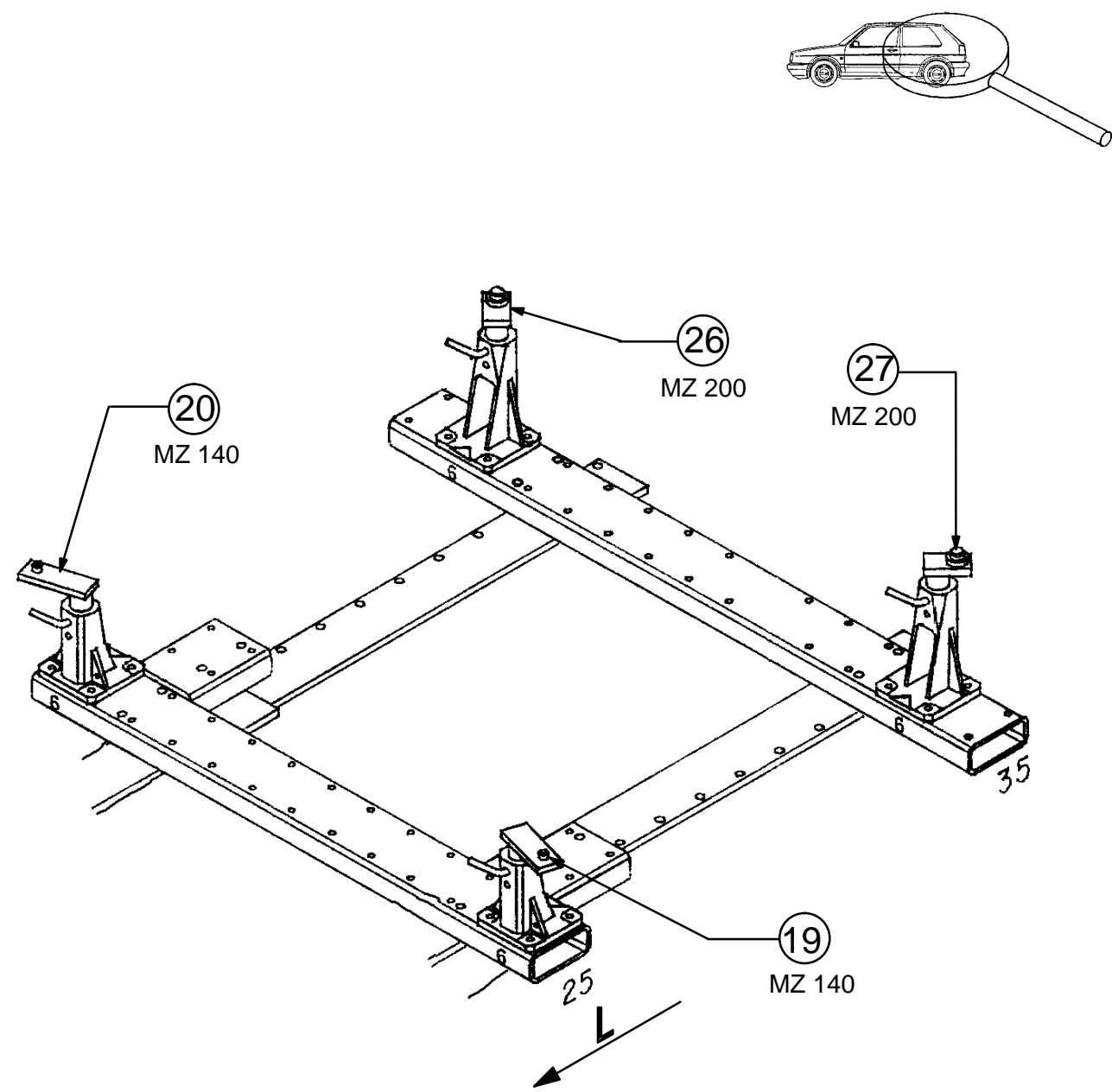
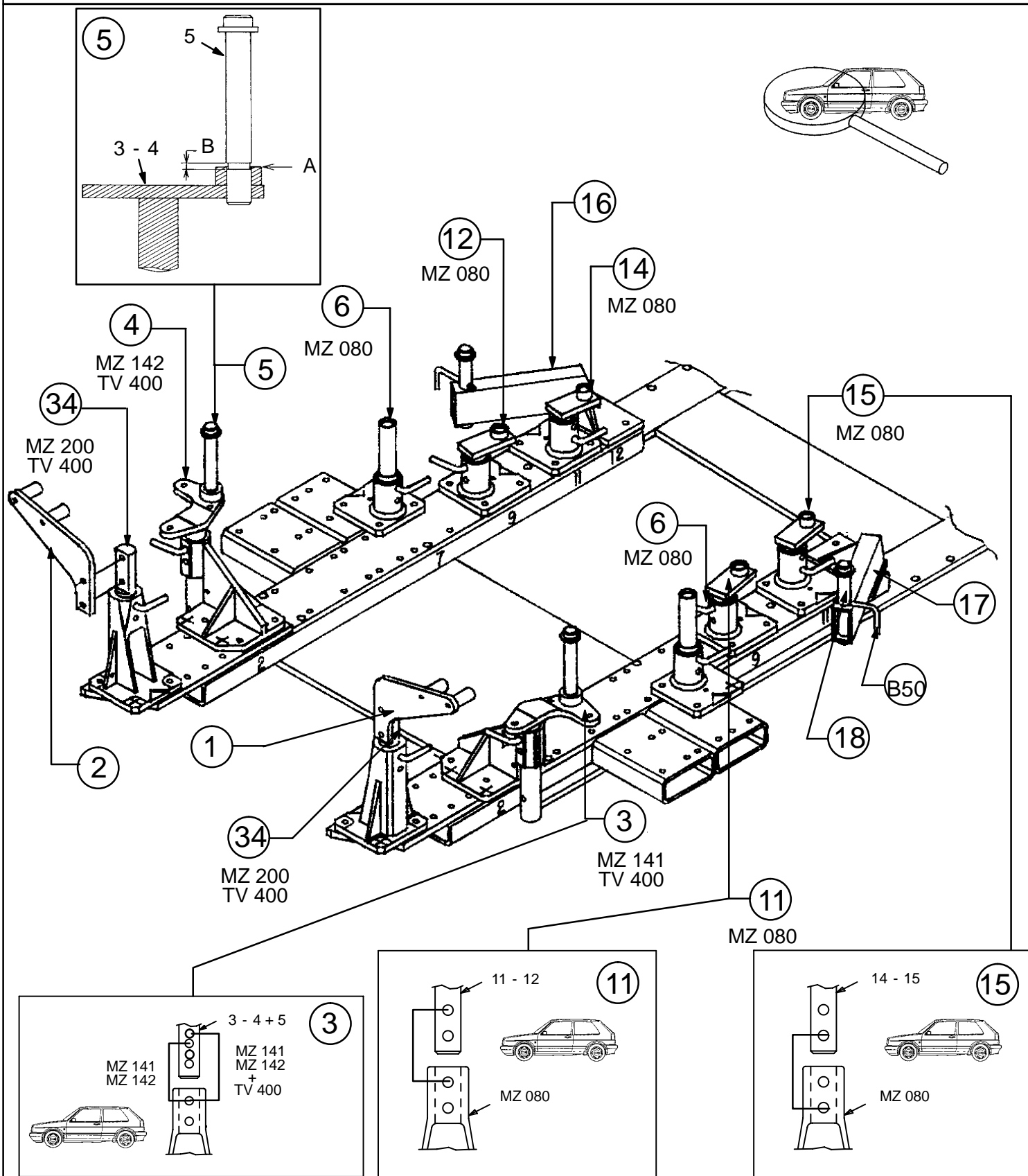

V.A.G 1740

82 Kg	438-D-11B	25.09.91
-------	-----------	----------

621.300

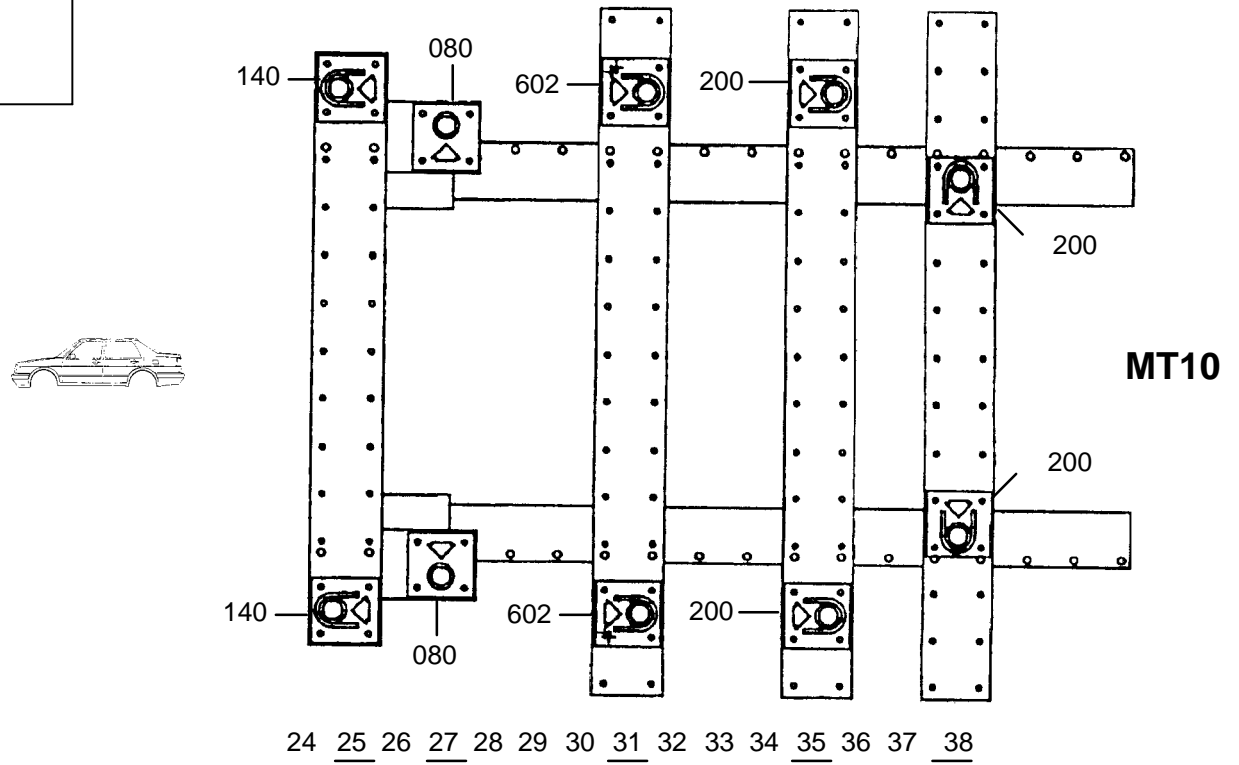
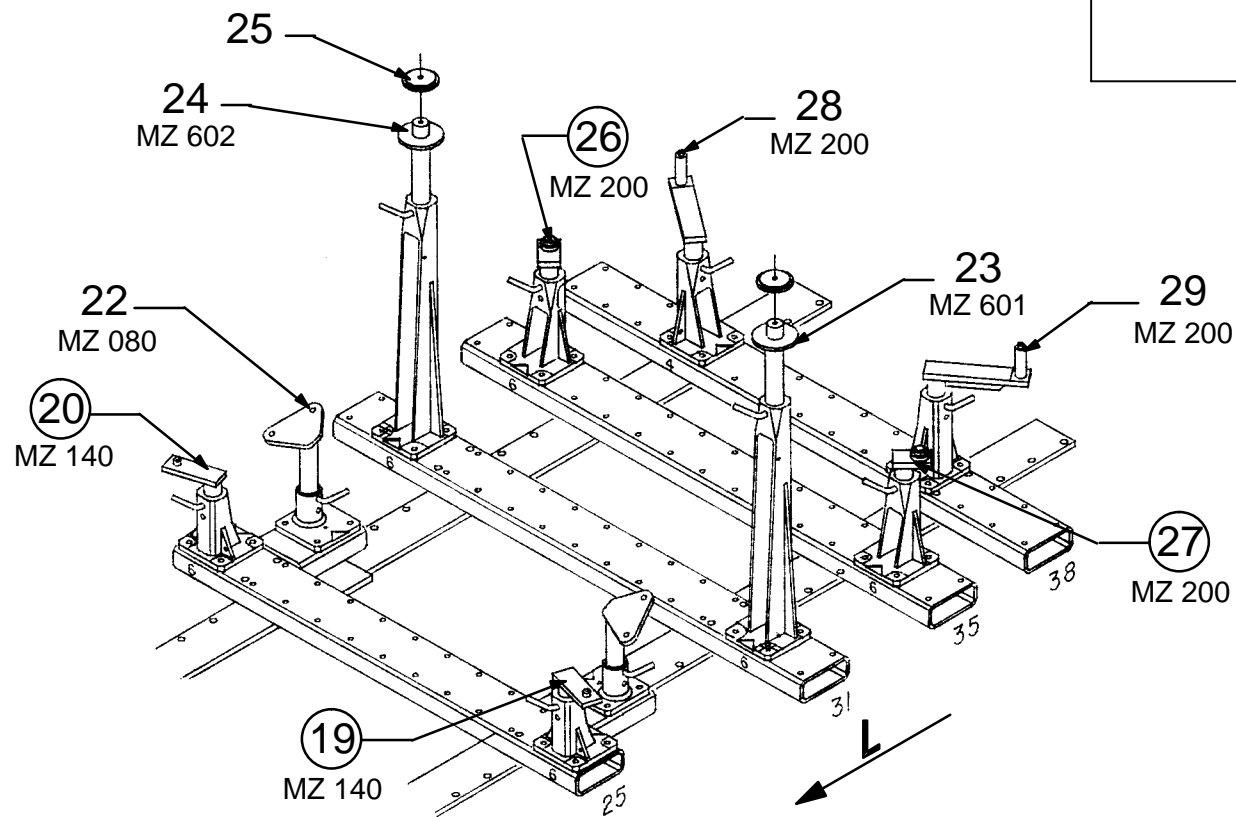
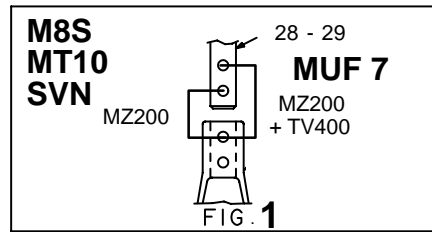
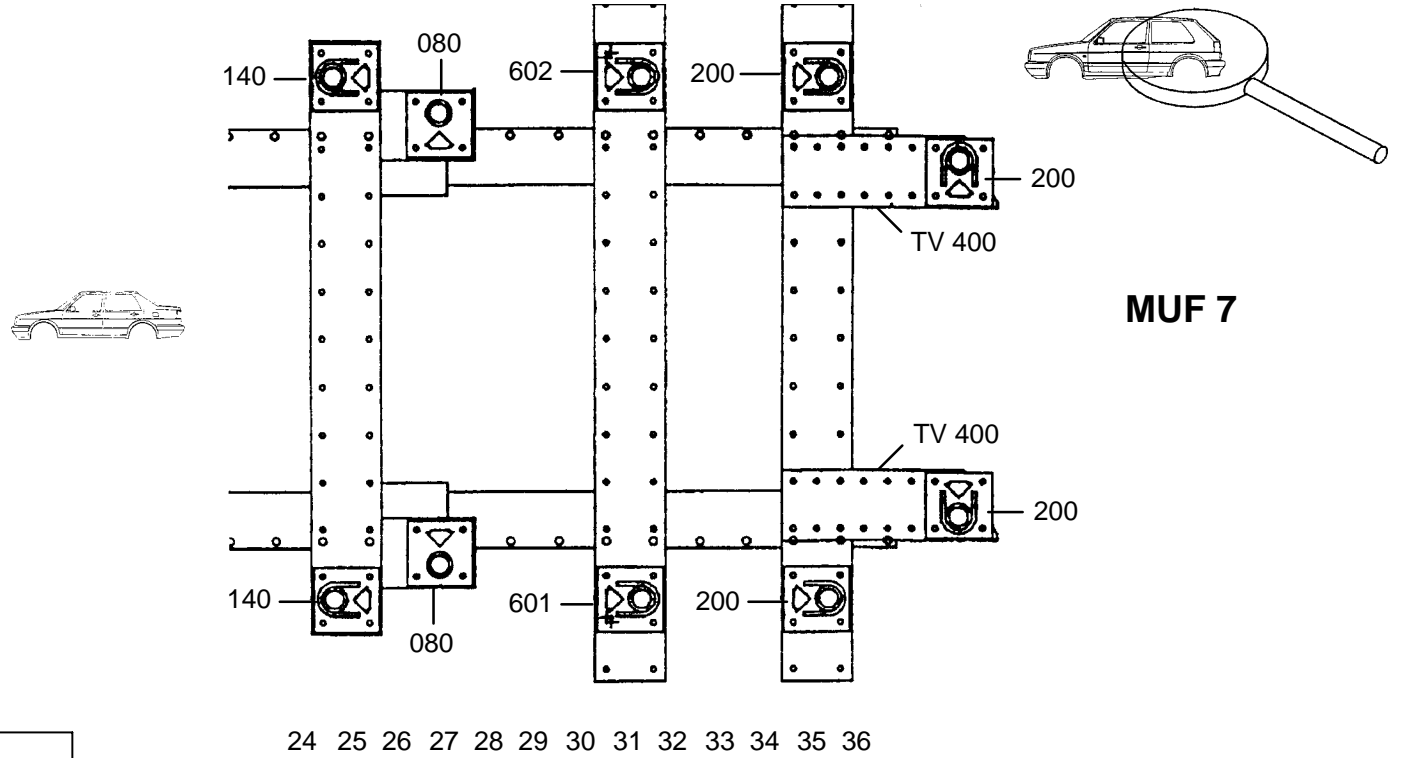
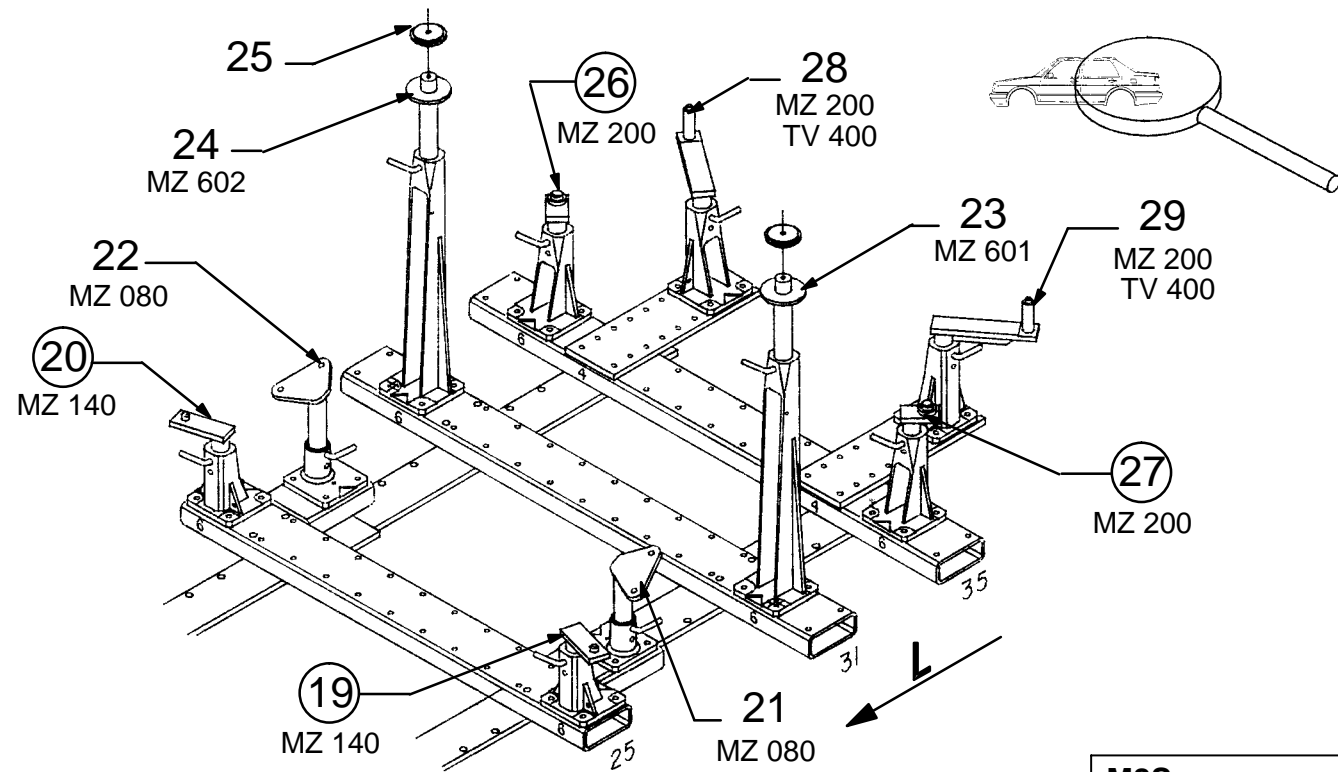

V.A.G 1740

82 Kg	438-D-11D	12.01.96
-------	-----------	----------

621.300



VOLKSWAGEN GOLF MOD.92 VENTO

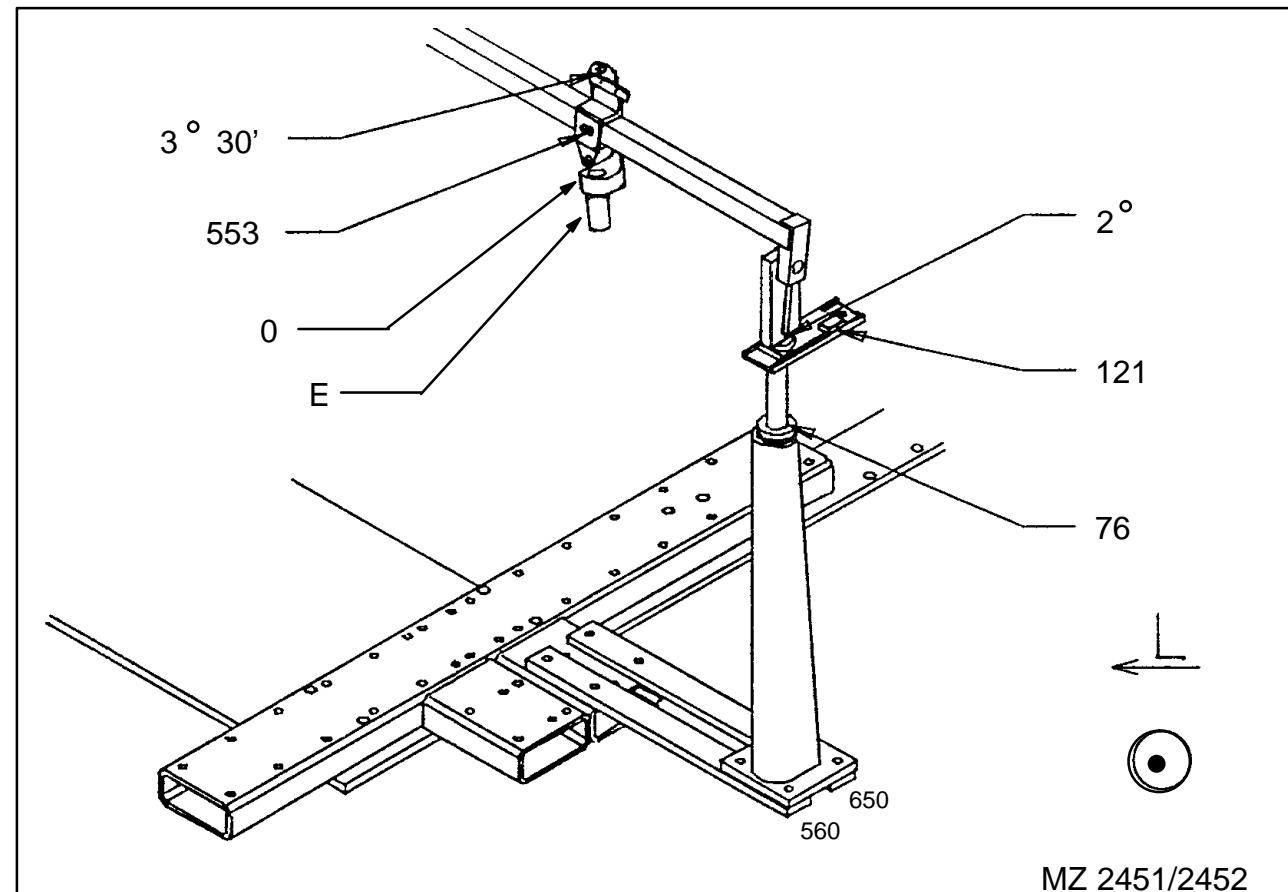

V.A.G 1740

82 Kg	438-D-11E	11.06.92
-------	-----------	----------

621.300