

RHD

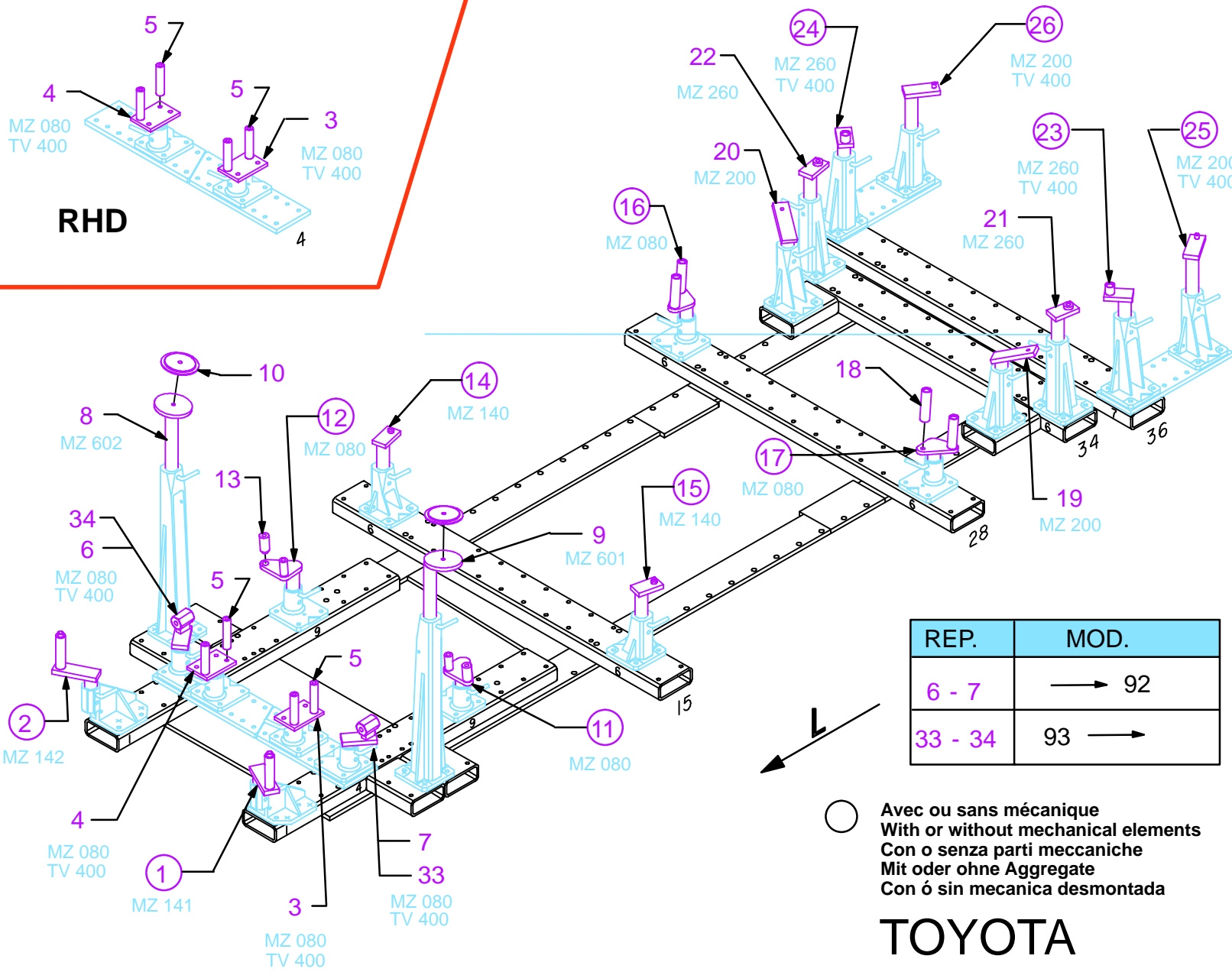

REP.	MOD.
6 - 7	→ 92
33 - 34	93 →

○ Avec ou sans mécanique
With or without mechanical elements
Con o senza parti meccaniche
Mit oder ohne Aggregate
Con ó sin mecanica desmontada

TOYOTA

REP.	REFERENCE	PDS	NB	MZ
1	619.701	2,5	1	141
2	619.702	2,5	1	142
3	619.703	1,7	1	080
4	619.704	1,7	1	080
5	619.705	0,4	4	
6	619.706	2,3	1	080
7	619.707	2,3	1	080
8	619.708	3,4	1	602
9	619.709	3,4	1	601
10	619.710	0,8	2	
11	619.711	2,2	1	080
12	619.712	2,2	1	080
13	619.713	0,3	2	
14	619.714	2,1	1	140
15	619.715	2,1	1	140
16	619.716	2,2	1	080
17	619.717	2,2	1	080
18	619.718	0,5	2	
19	619.719	2,2	1	200
20	619.720	2,2	1	200
21	619.721	2,1	1	260
22	619.722	2,1	1	260
23	619.723	1,9	1	260
24	619.724	1,9	1	260
25	619.725	2,9	1	200
26	619.726	2,9	1	200
27	619.727	2,6	1	080
28	619.728	2,6	1	080
29	619.729	1,1	2	
30	619.730	2,3	1	200
31	619.731	2,3	1	200
32	619.732	2,3	1	140
33	619.733	2,3	1	080
34	619.734	2,3	1	080
E 30		0,1	2	

M8x25	2
M12x25	14
M12.125x90	4
M12.125x100	2
M12.125x110	2
M12.125x140	6
MU 12	2

619.310

76 Kg 16.04.93 434-D-35D

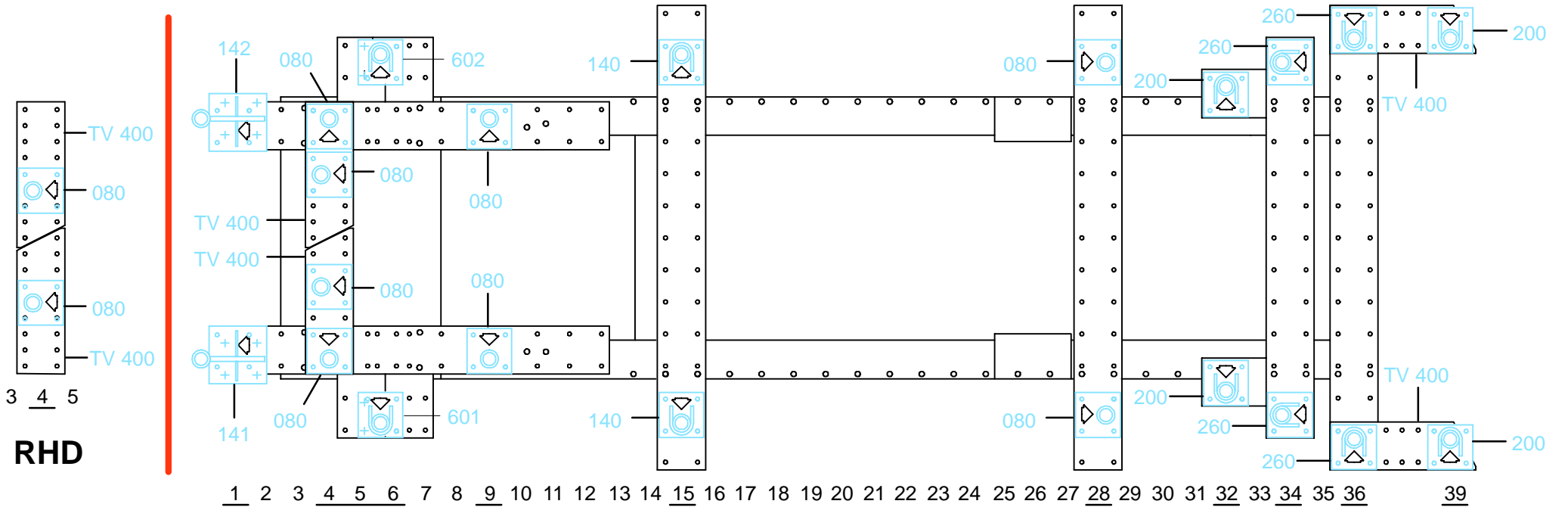

RHD

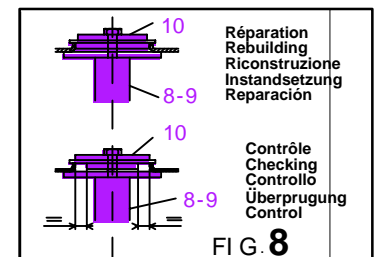
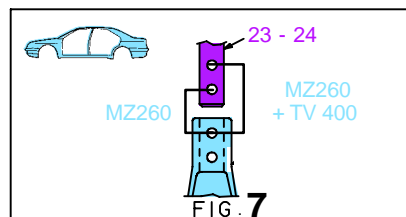
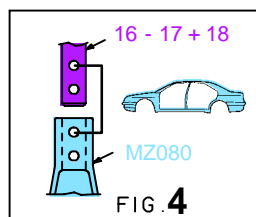
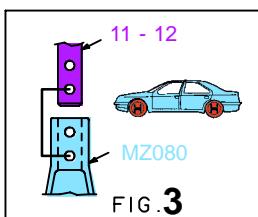
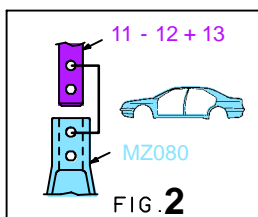
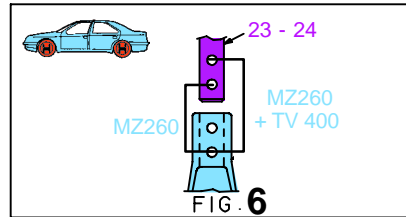
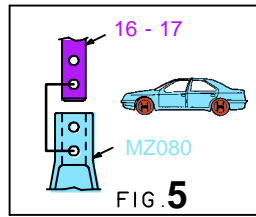
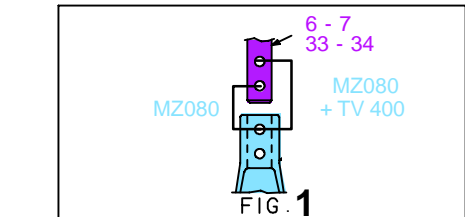

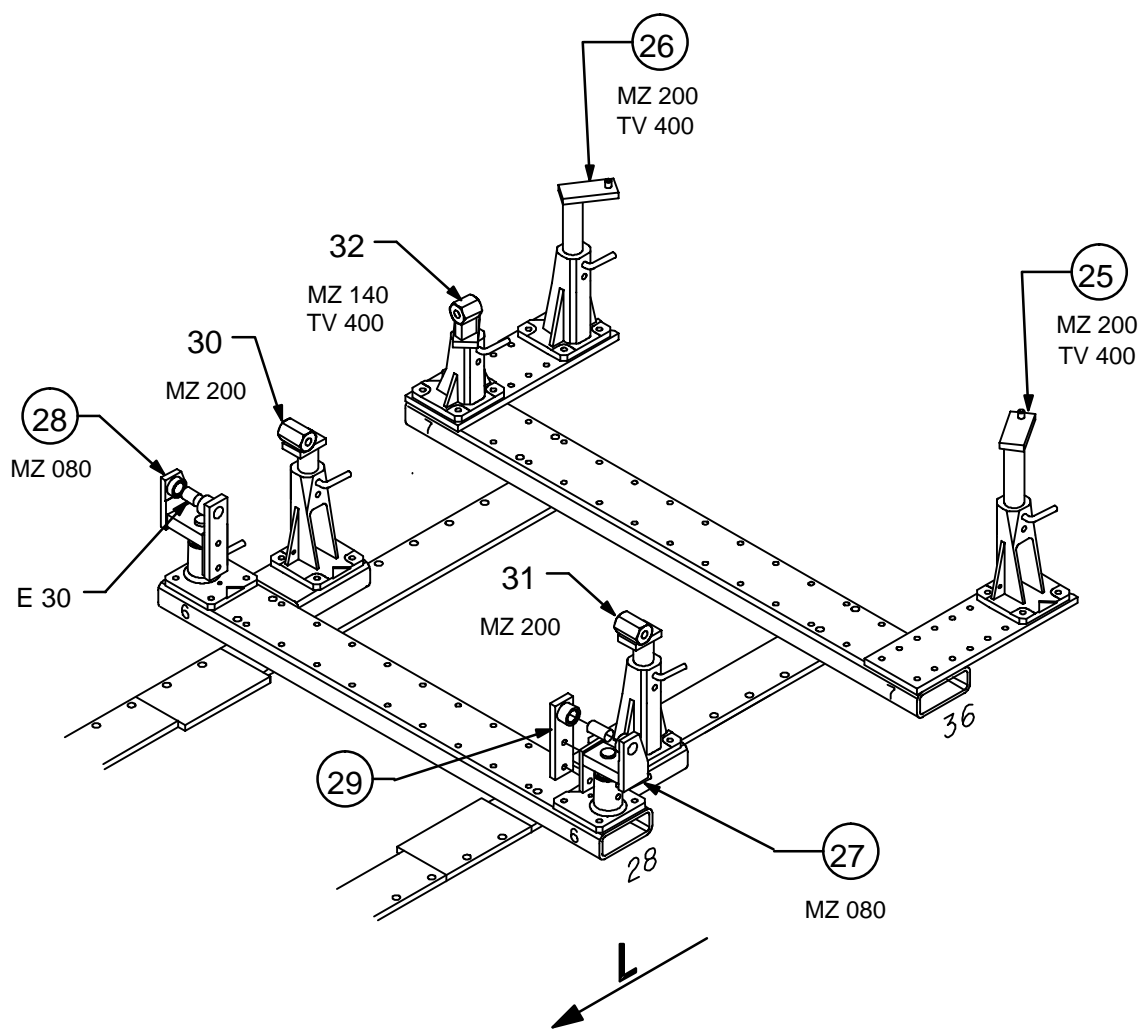

○ Avec ou sans mécanique
With or without mechanical elements
Con o senza parti meccaniche
Mit oder ohne Aggregate
Con ó sin mecanica desmontada

TOYOTA

619.310

76 Kg	16.04.93	434-D-35E
-------	----------	-----------

