

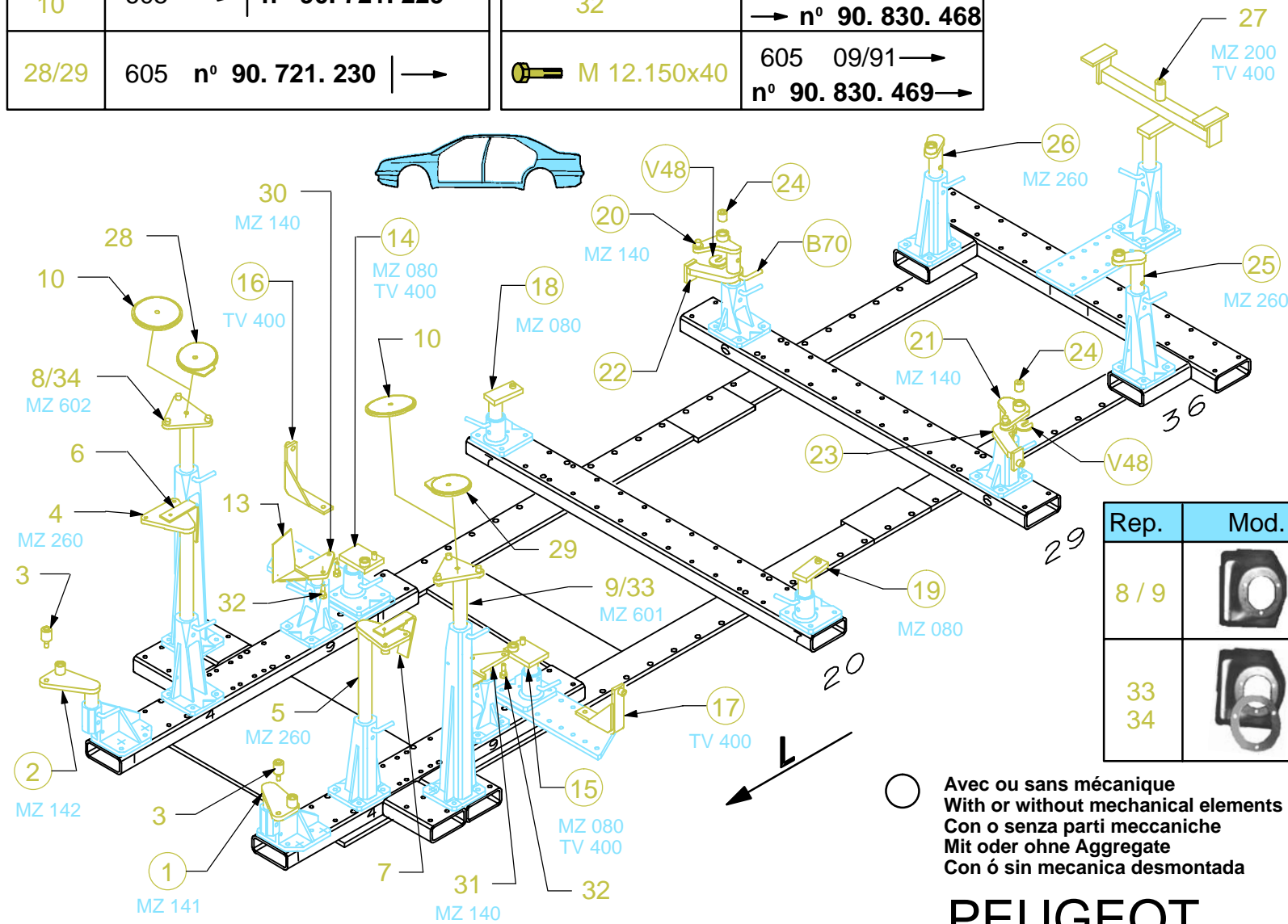



REP.	MOD.
10	605 → n° 90.721.229
28/29	605 n° 90.721.230 →



REP.	MOD.
32	605 → 08/91 → n° 90.830.468
 M 12.150x40	605 09/91 → n° 90.830.469 →

REP.	REFERENCE	PDS	NB	MZ
1	605.701	2,6	1	141
2	605.702	2,6	1	142
3	605.703	0,4	2	
4	605.704	5,3	1	260
5	605.705	5,3	1	260
6	605.706	0,4	1	
7	605.707	0,4	1	
8	605.708	4,7	1	602
9	605.709	4,7	1	601
10	605.710	1,4	2	
13	605.713	0,3	1	
14	605.714	2,0	1	080
15	605.715	2,0	1	080
16	605.716	1,5	1	
17	605.717	1,5	1	
18	605.718	1,9	1	080
19	605.719	1,9	1	080
20	605.720	3,0	1	140/080
21	605.721	3,0	1	140/080
22	605.722	1,1	1	
23	605.723	1,1	1	
24	605.724	0,1	2	
25	605.725	2,3	1	260
26	605.726	2,3	1	260
27	605.727	5,9	1	200
28	605.728	1,5	1	
29	605.729	1,5	1	
30	605.730	2,2	1	140
31	605.731	2,2	1	140
32	605.732	0,1	4	
33	605.733	4,7	1	601
34	605.734	4,7	1	602
35	605.735	2,9	1	260
	V48	0,1	2	
	B70	0,2	2	



Rep.	Mod.
8 / 9	
33	
34	

○ Avec ou sans mécanique
With or without mechanical elements
Con o senza parti meccaniche
Mit oder ohne Aggregate
Con ó sin mecanica desmontada

M8x20	2
M8x30	3
M8x45	1
M10x50	2
M10x60	2
M10x70	2
M10x100	2
M10x120	2
M12x25	4
M12x45	2
M12x60	4
M12x120	2
M12x130	2
M12.150x40	4
 M14x25	4
 M10	2
 M10	4

PEUGEOT

605.340

82 Kg 04.10.94 423-D-12W

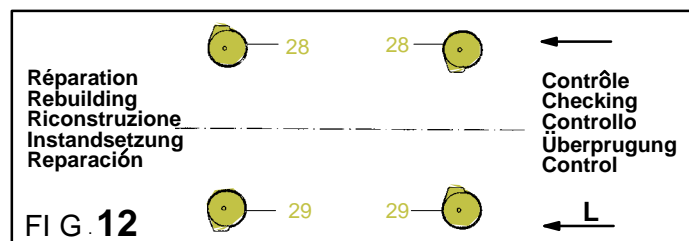
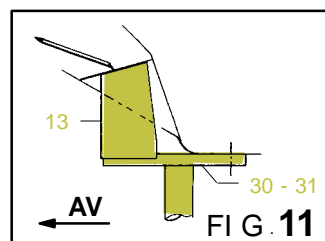
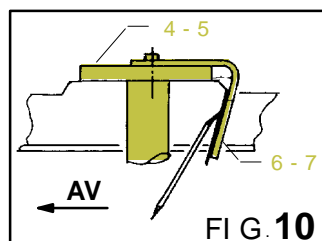
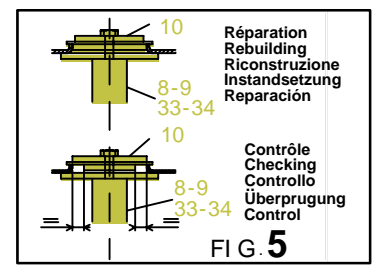
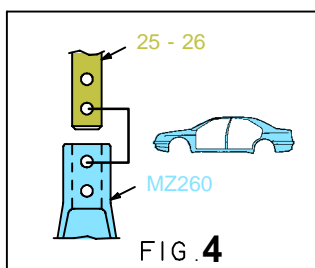
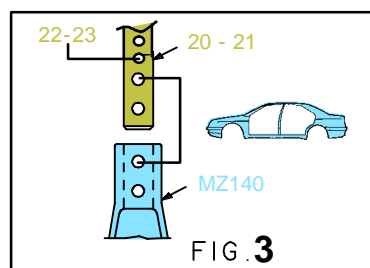
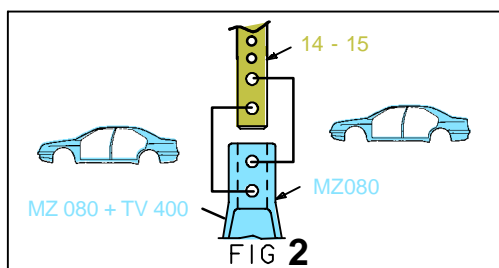
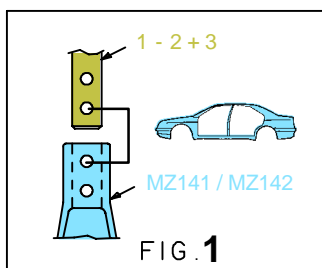
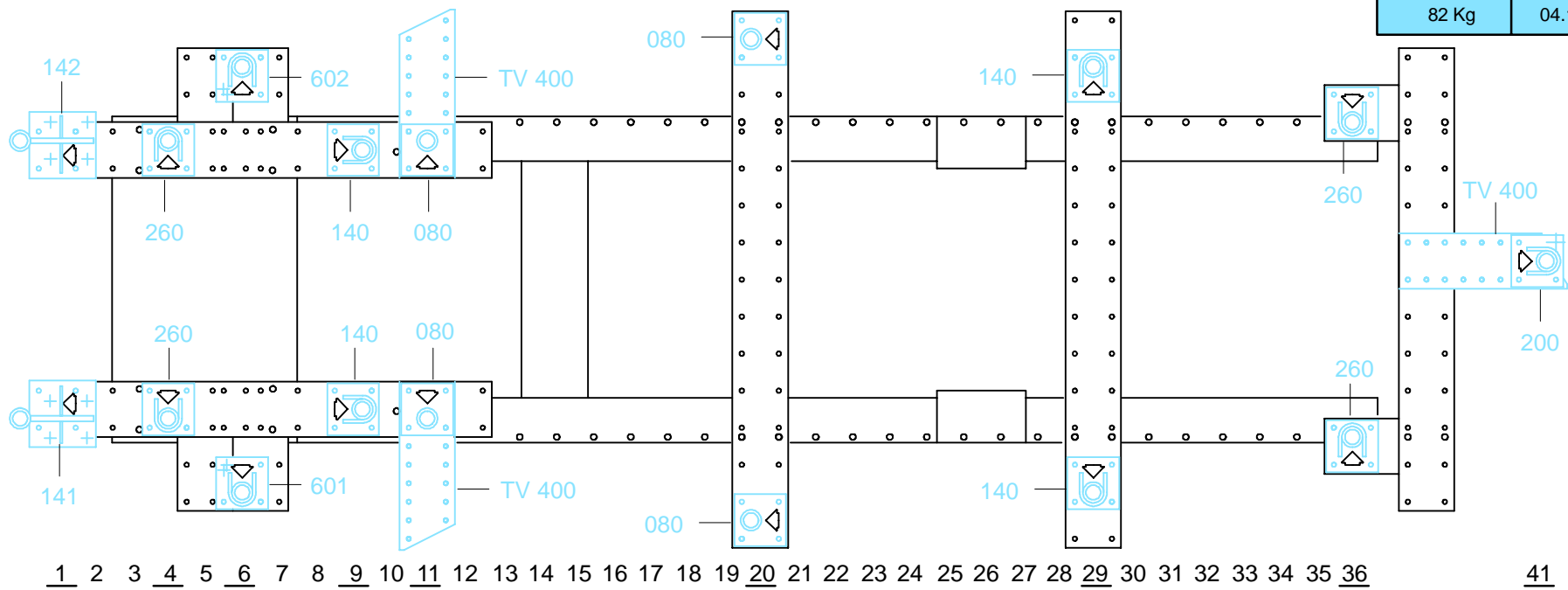

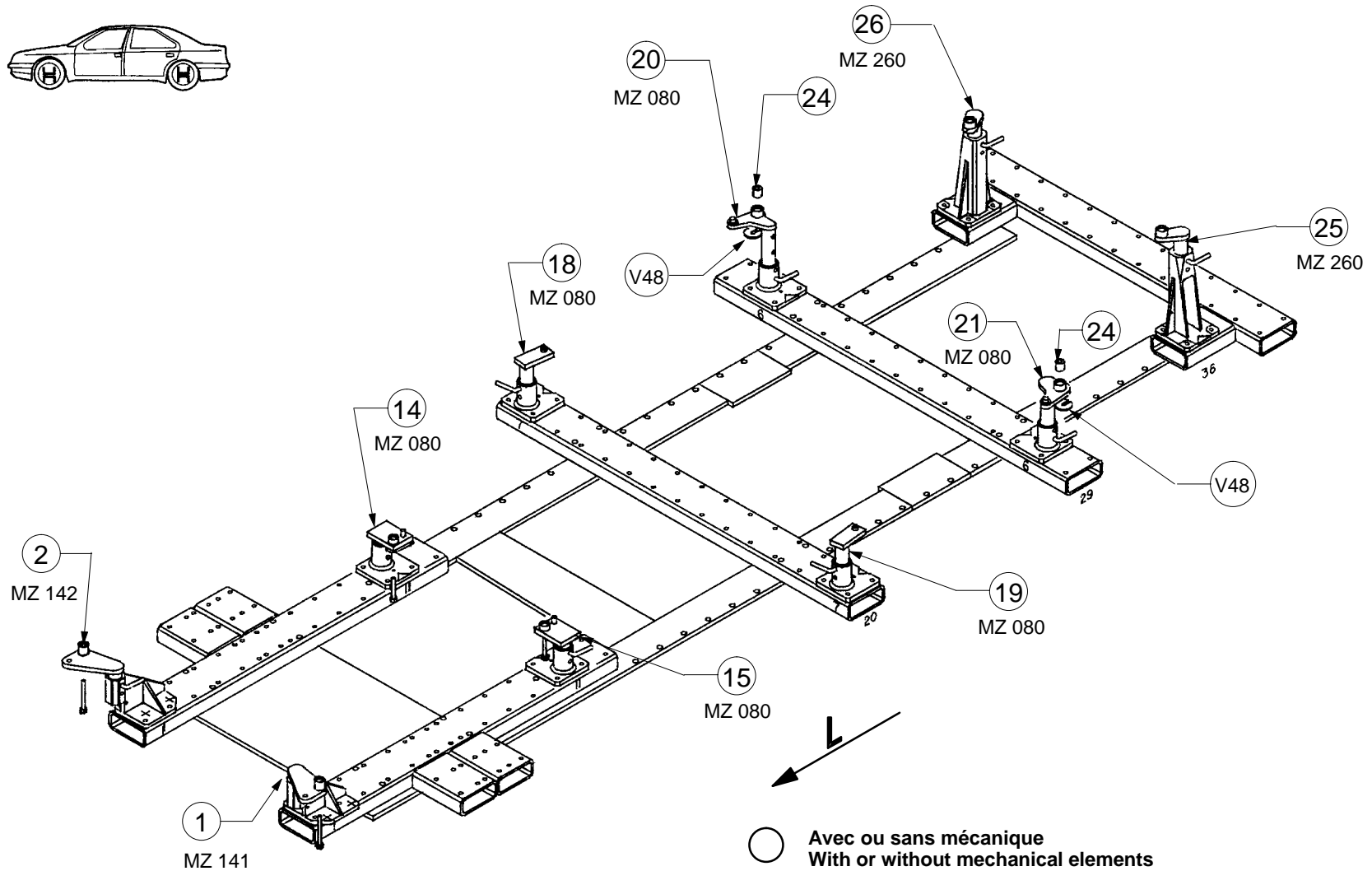

○ Avec ou sans mécanique
 With or without mechanical elements
 Con o senza parti meccaniche
 Mit oder ohne Aggregate
 Con ó sin mecanica desmontada

PEUGEOT

605.340

82 Kg 04.10.94 423-D-12X

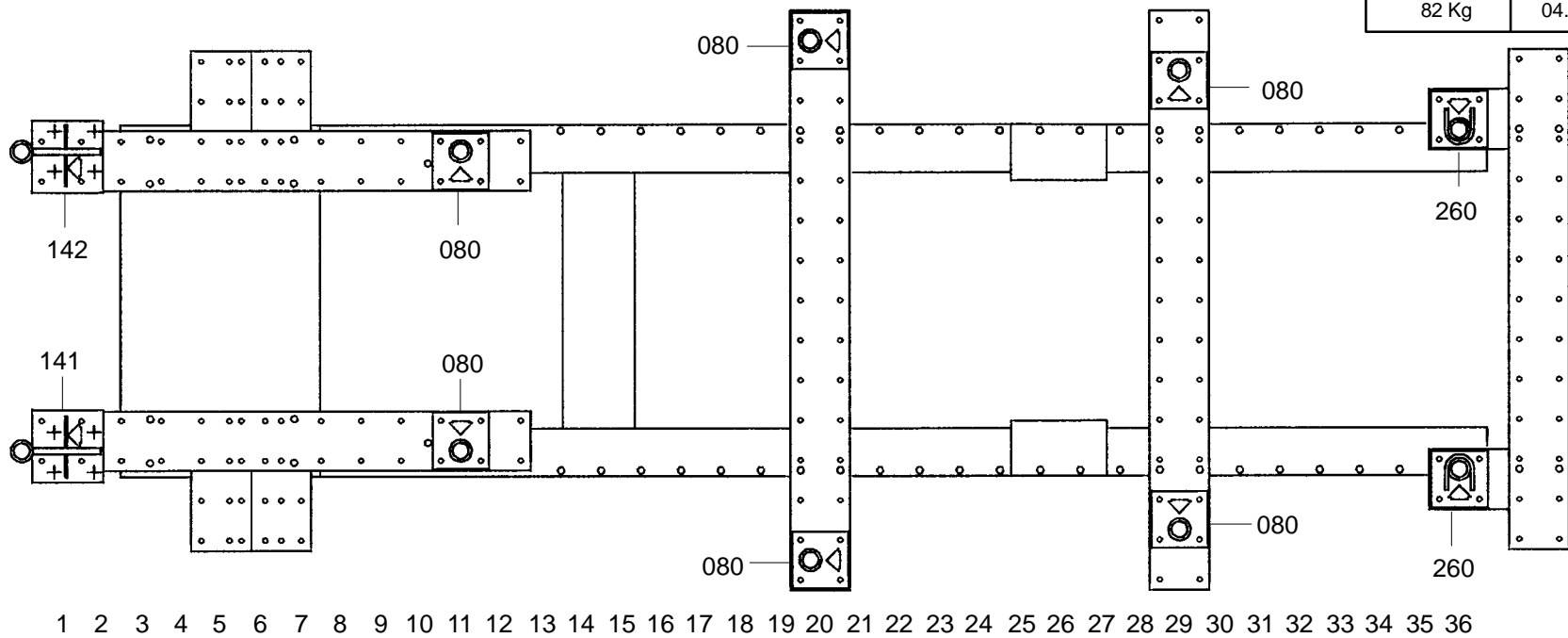

1 2 3 4 5 6 7 8 9 10 11 12 13 14 15 16 17 18 19 20 21 22 23 24 25 26 27 28 29 30 31 32 33 34 35 36

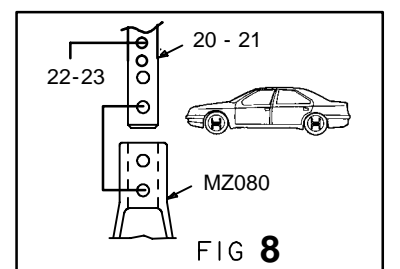
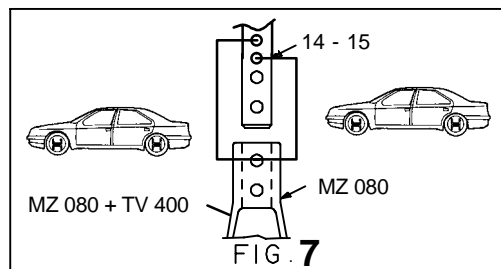
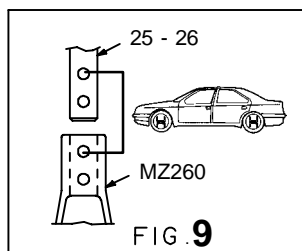
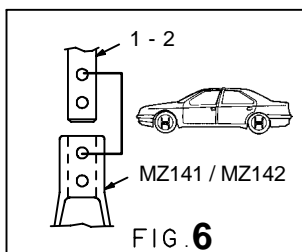
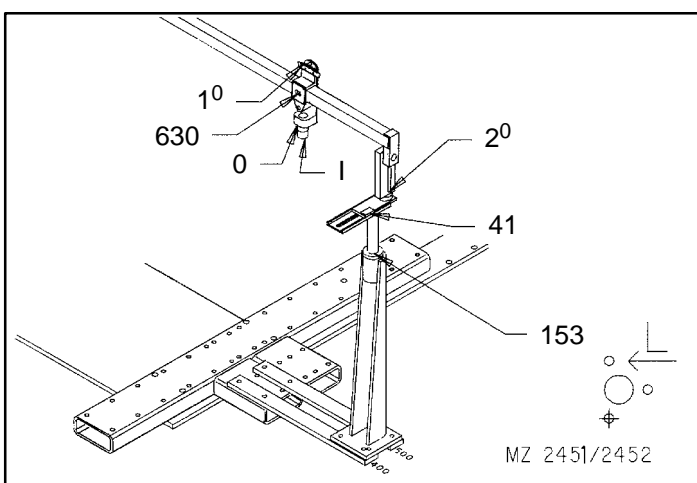

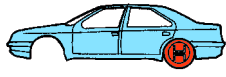

REP.	MOD.
10	605 → n° 90.721.229
28/29	605 n° 90.721.230 →

Rep.	Mod.
8 / 9	
33 34	

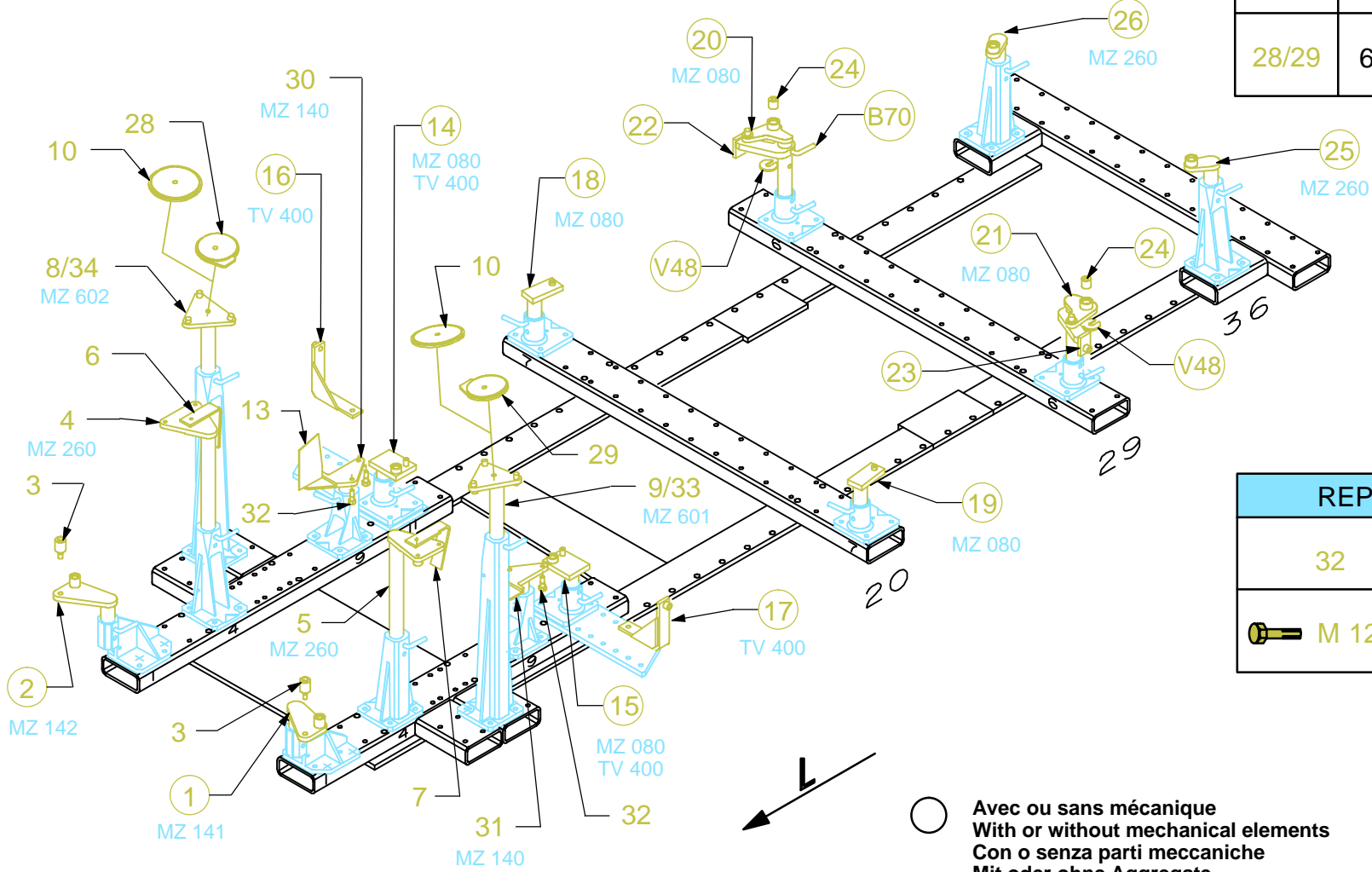

○ Avec ou sans mécanique
 With or without mechanical elements
 Con o senza parti meccaniche
 Mit oder ohne Aggregate
 Con ó sin mecanica desmontada

REP.	MOD.
32	605 → 08/91 → n° 90.830.468
	605 09/91 → n° 90.830.469 →

PEUGEOT

605.340

82 Kg 04.10.94 423-D-12Y

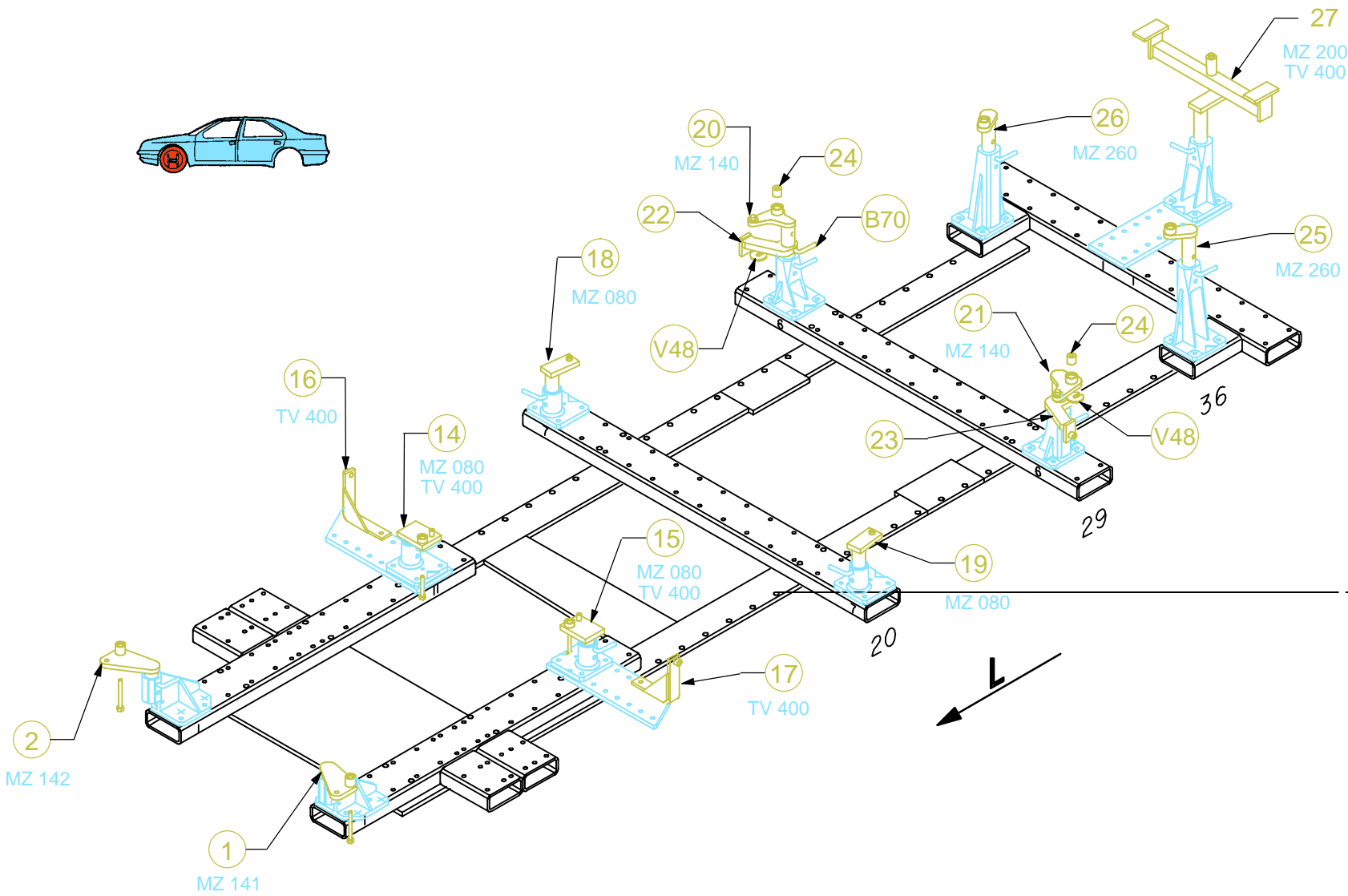
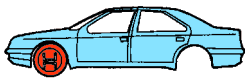

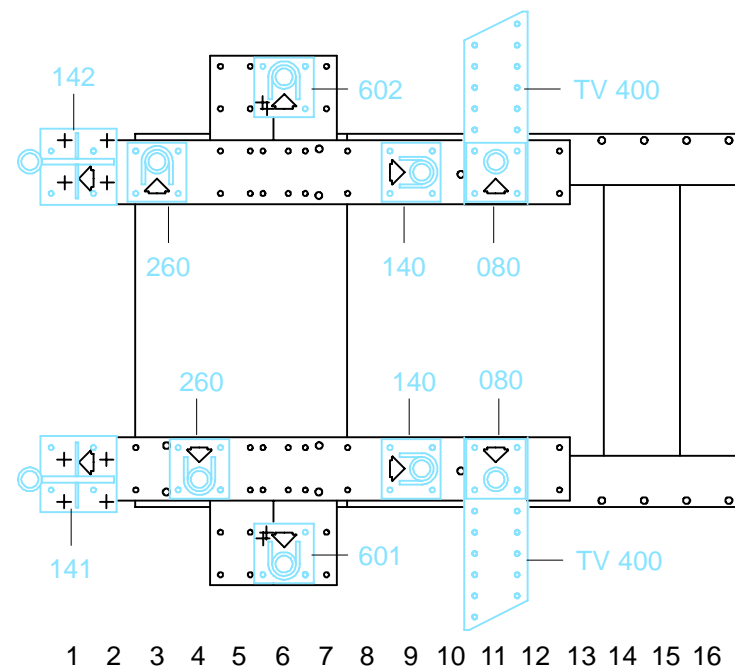
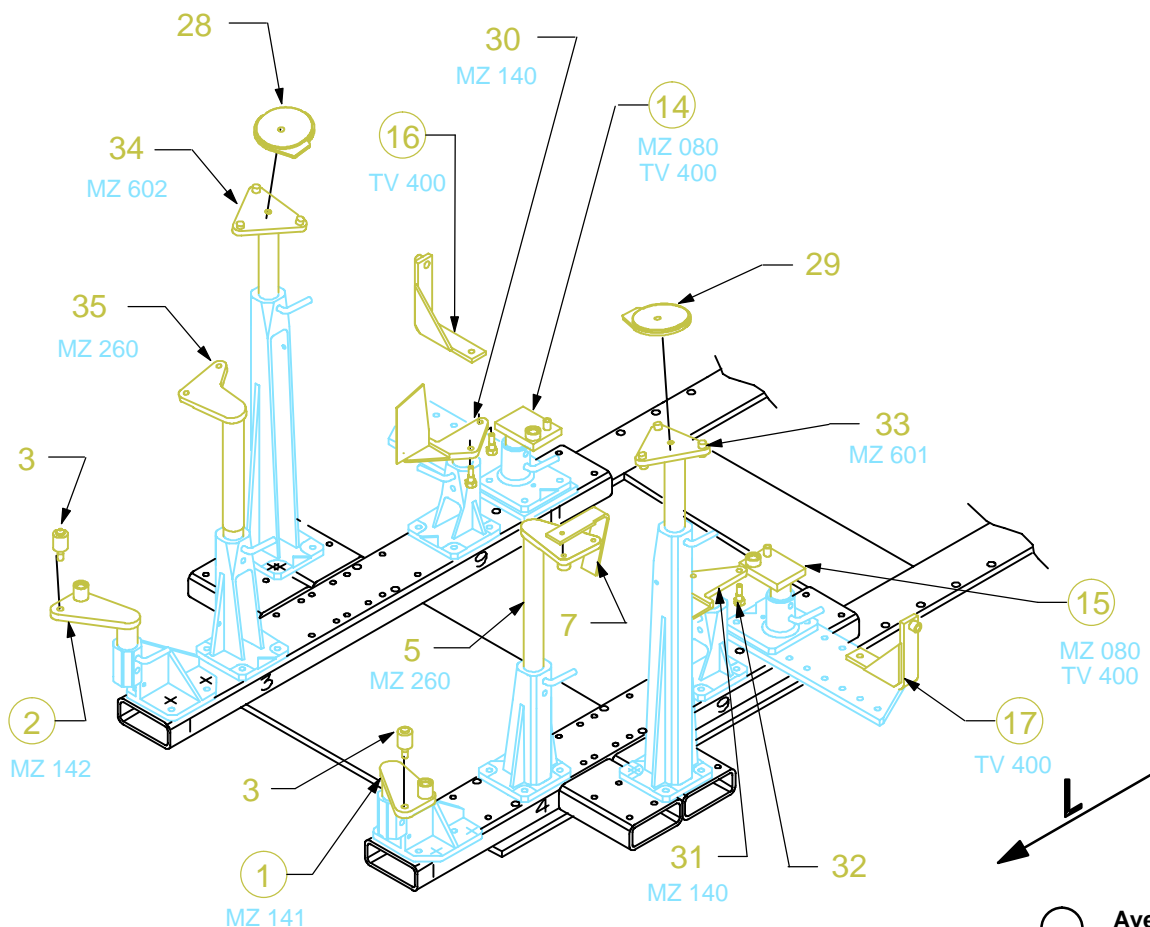

○ Avec ou sans mécanique
 With or without mechanical elements
 Con o senza parti meccaniche
 Mit oder ohne Aggregate
 Con ó sin mecanica desmontada

PEUGEOT

605.340		
82 Kg	05.10.94	423-D-12Z