

REP.	REFERENCE	PDS	NB	MZ
1	584.701	3,4	1	260
2	584.702	3,4	1	260
3	584.703	3,2	1	200
4	584.704	3,2	1	200
5	584.705	0,6	2	
6	584.706	3,8	1	602
7	584.707	3,8	1	601
8	584.708	1,9	1	080
9	584.709	1,9	1	080
10	584.710	1,5	1	080
11	584.711	1,5	1	080
12	584.712	4,0	1	080
13	584.713	4,0	1	080
14	584.714	0,6	4	
15	584.715	3,5	1	601
16	584.716	3,5	1	602
17	584.717	0,5	2	
18	584.718	2,6	1	260/140
19	584.719	2,6	1	260/140
20	584.720	1,6	2	
21	584.721	2,0	1	260
22	584.722	2,0	1	260
23	584.723	0,5	2	
24	584.724	2,7	1	200
25	584.725	2,7	1	200
26	584.726	4,0	2	
27	584.727	3,0	6	

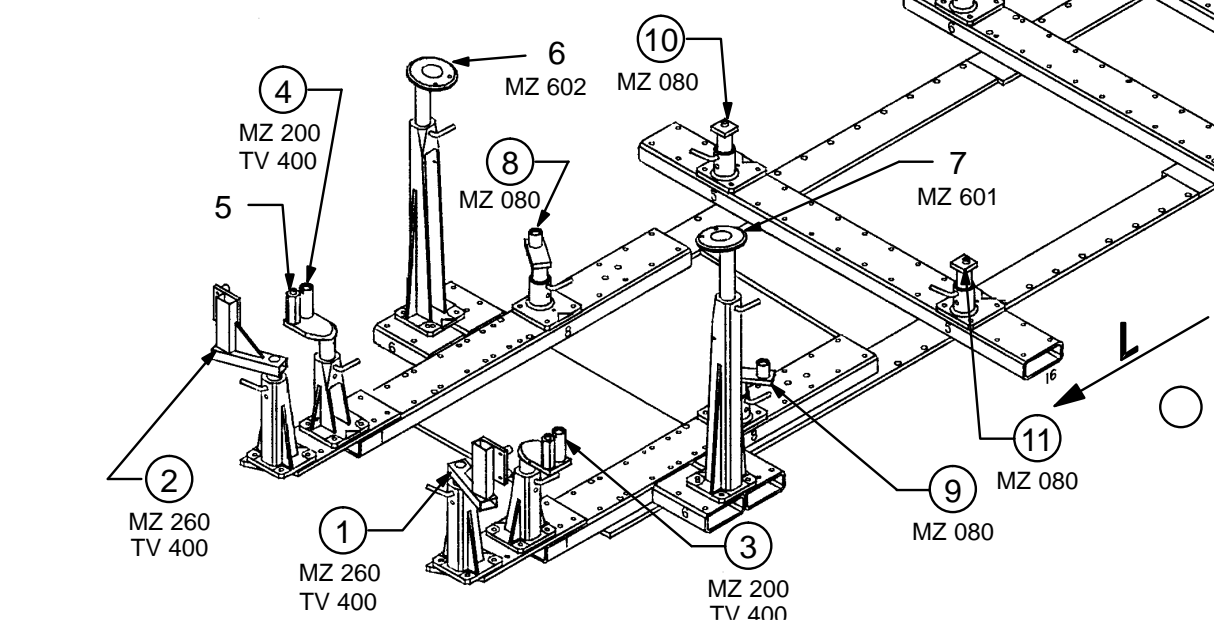

Avec ou sans mécanique  
 With or without mechanical elements  
 Con o senza parti meccaniche  
 Mit oder ohne Aggregate  
 Con ó sin mecanica desmontada

	M 6x40	4
	M 8x25	4
	M 10x25	4
	M 12x25	32
	M 12x30	6
	M 12x40	4
	M 12x90	4
	M 14x80	2
	M 14x100	2
	M 14x130	2
	CHC 12x25 TB	28

GM

584.300

94 Kg	20.04.93	440-D-15A
-------	----------	-----------

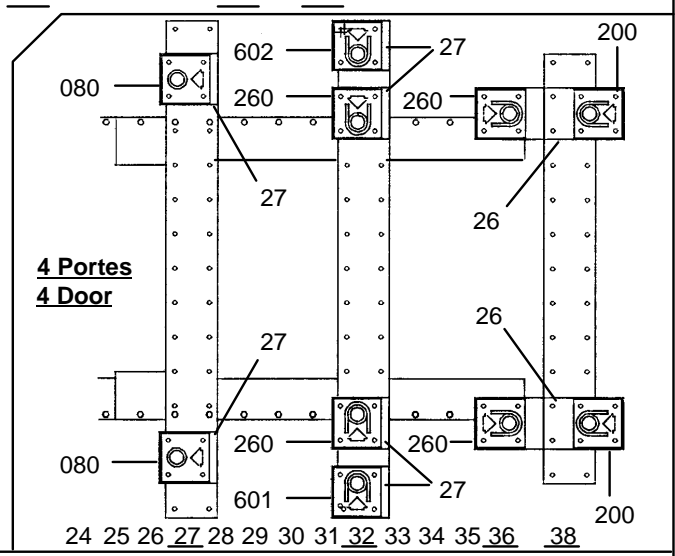
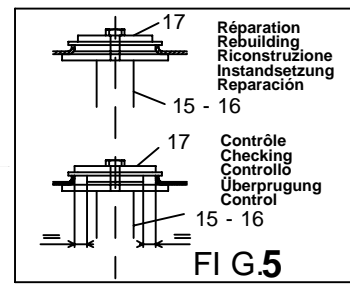
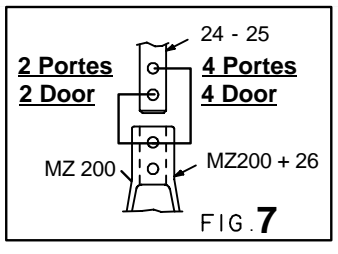
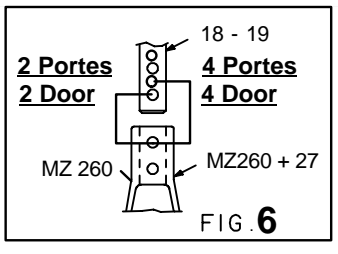
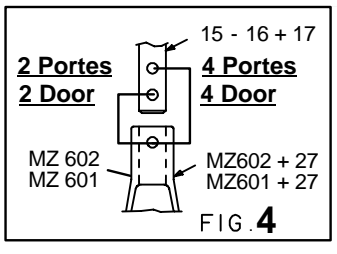
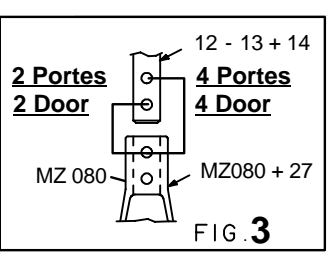
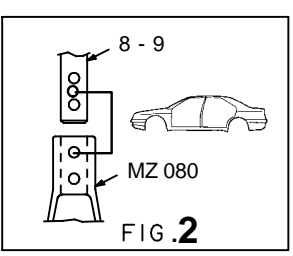
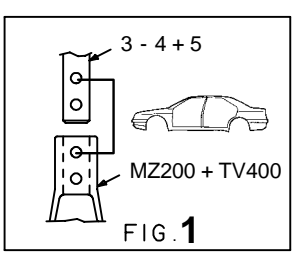
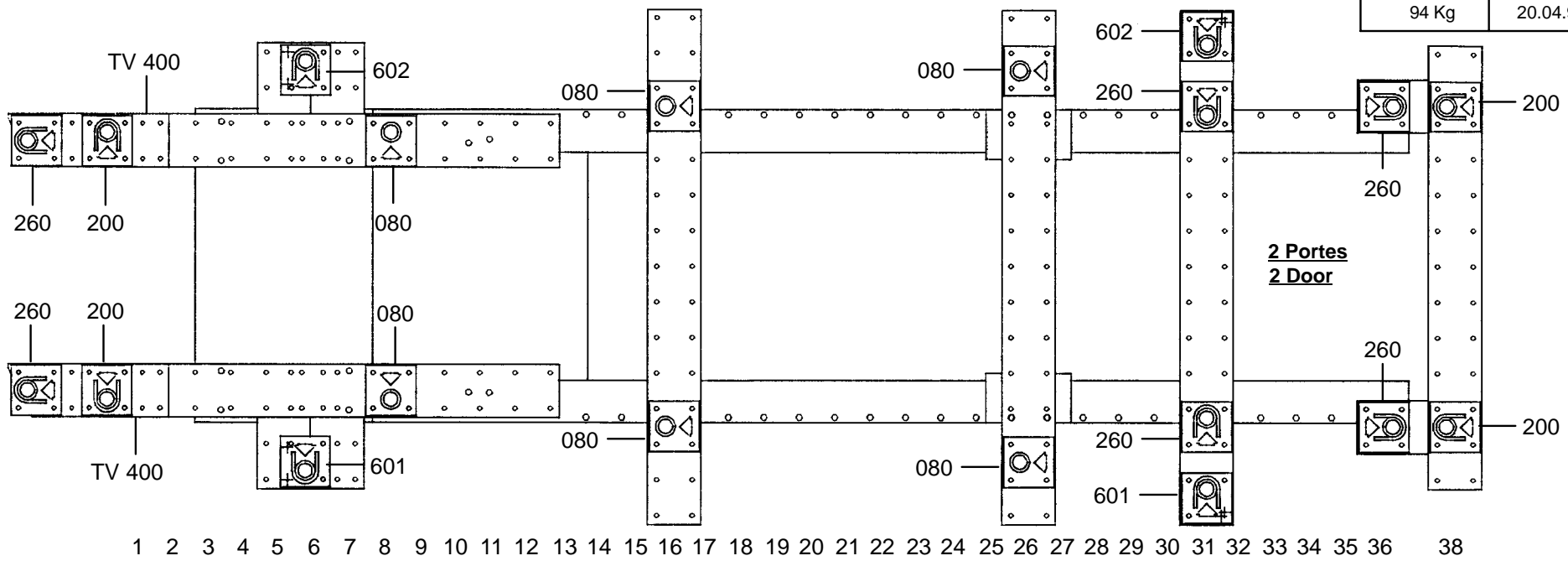

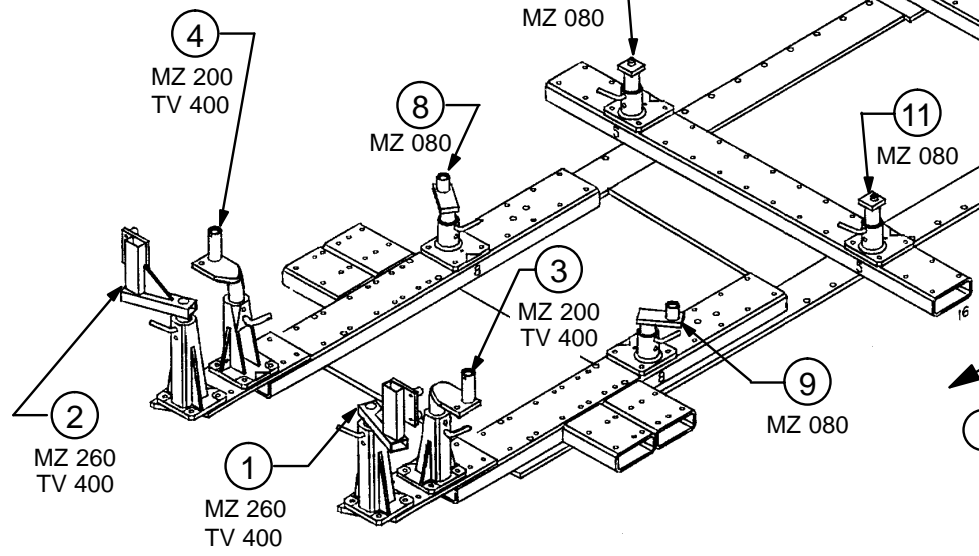
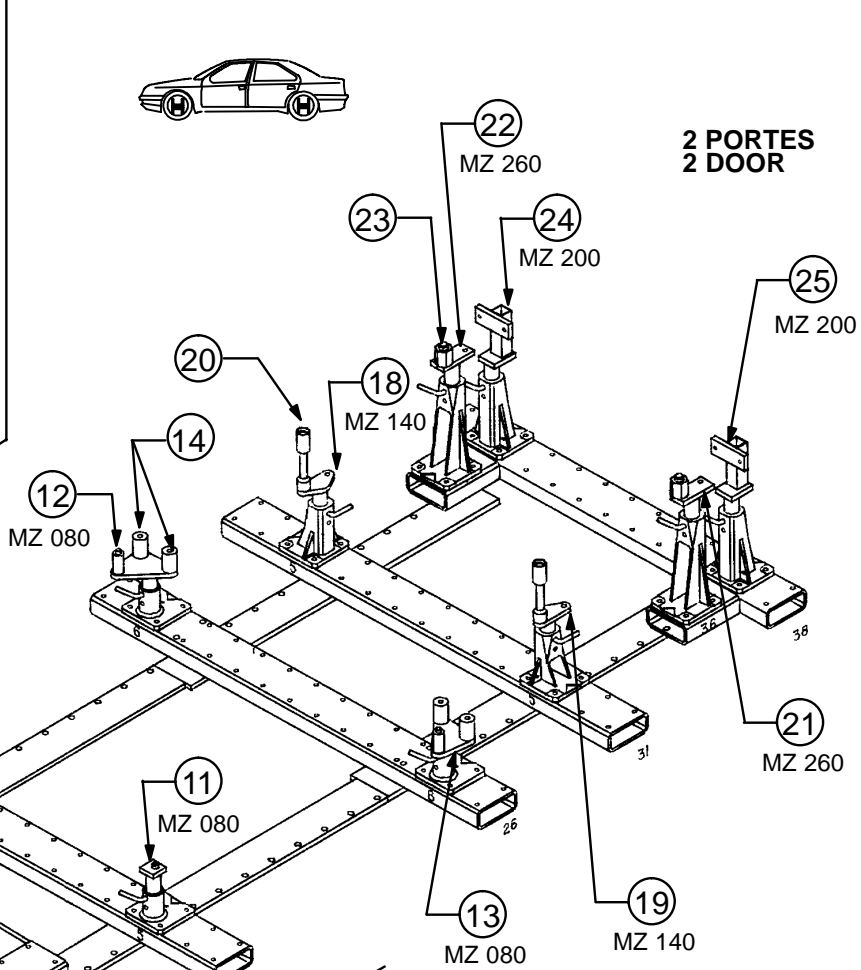
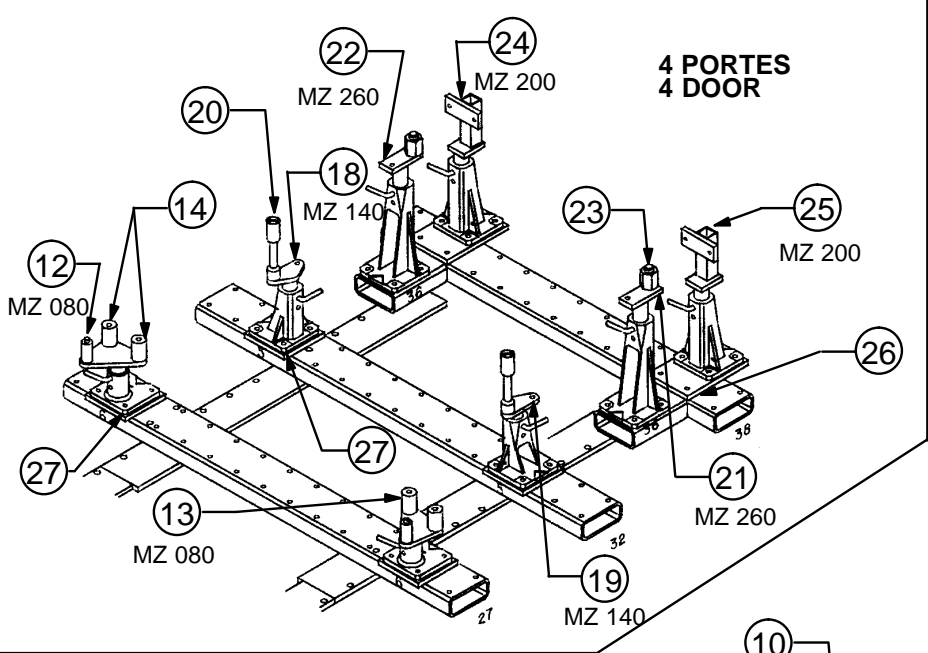

○ Avec ou sans mécanique  
 With or without mechanical elements  
 Con o senza parti meccaniche  
 Mit oder ohne Aggregate  
 Con ó sin mecanica desmontada

<b>584.300</b>		
94 Kg	15.10.90	440-D-15B

**GM**

