

* (19) = Uniquement pour SUZUKI Alto
 Only for SUZUKI Alto
 Nur für SUZUKI Alto
 Soltanto per SUZUKI Alto
 Para SUZUKI Alto unicamente

AN9 } AN22 } **Necessaire pour ancrage**
Anchoring equipment
Verankerungsaurüstung
Attrezzatura per ancoraggio
Necesario para anclaje

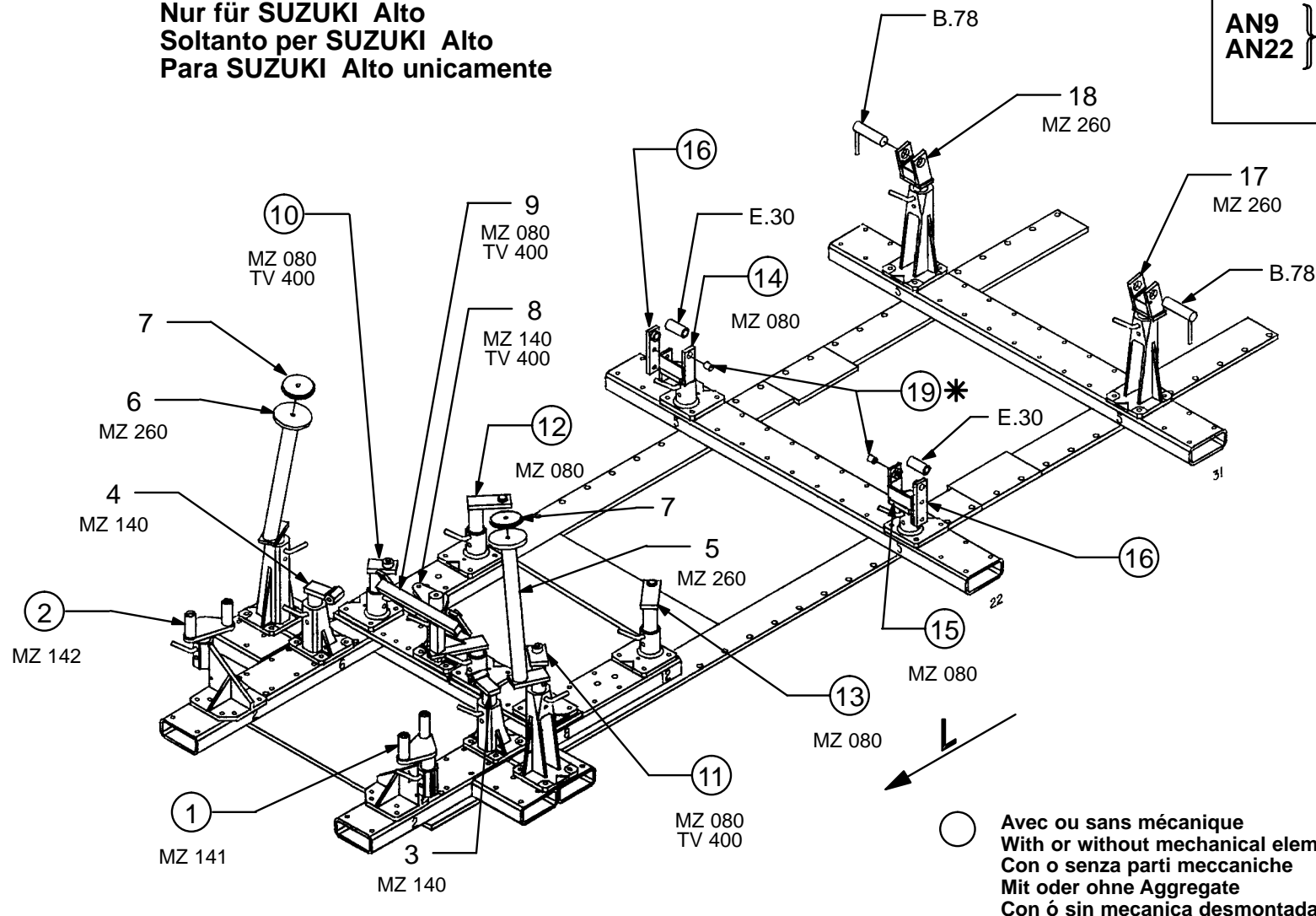

REP.	REFERENCE	PDS	NB	MZ
1	581.701	2,6	1	141
2	581.702	2,6	1	142
3	581.703	1,7	1	140
4	581.704	1,7	1	140
5	581.705	3,8	1	260
6	581.706	3,8	1	260
7	581.707	0,7	2	
8	581.708	2,2	1	140
9	581.709	3,8	1	080
10	581.710	1,9	1	080
11	581.711	1,9	1	080
12	581.712	2,0	1	080
13	581.713	2,0	1	080
14	581.714	2,3	1	080
15	581.715	2,3	1	080
16	581.716	0,6	2	
17	581.717	2,5	1	260
18	581.718	2,5	1	260
19	581.719	0,1	2	
	B.78	0,7	2	
	E.30	0,1	2	

	M 8x25	3
	M 8x30	1
	M 10.125x30	1
	M 10.125x75	1
	M 10.125x100	4
	M 12x20	2
M 12x30	4	

MARUTI/SUZUKI

581.300

45 Kg 26.02.90 445-D-3A

