

○ Avec ou sans mécanique
With or without mechanical elements
Con o senza parti meccaniche
Mit oder ohne Aggregate
Con ó sin mecanica desmontada

REP.	REFERENCE	PDS	NB	MZ
1	570.701	1,9	1	140
2	570.702	1,9	1	140
3	570.703	1,5	1	140
4	570.704	1,5	1	140
5	570.705	0,5	2	
6	570.706	2,7	1	200
7	570.707	2,7	1	200
8	570.708	3,1	1	602
9	570.709	3,1	1	601
10	570.710	0,6	2	
11	570.711	1,3	1	080
12	570.712	1,3	1	080
13	570.713	3,2	1	080
14	570.714	3,2	1	080
15	570.715	1,2	2	
16	570.716	0,3	2	
17	570.717	2,7	1	260
18	570.718	2,7	1	260
19	570.719	2,7	1	601
20	570.720	2,7	1	602
21	570.721	0,7	2	
22	570.722	2,6	1	142
23	570.723	2,5	1	141

	M 10x25 M 12x20 M 12.125x20 M 12x120	12 4 4 4
--	---	-------------------

	M 10 M 12	12 4
--	--------------	---------

	L 12 M 12	4 2
--	--------------	--------

NISSAN

570.300

49Kg	14.01.91	410-D-33A
------	----------	-----------

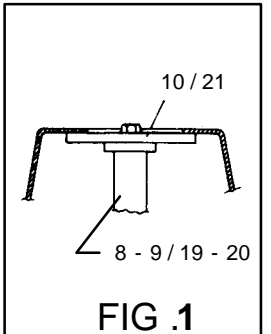
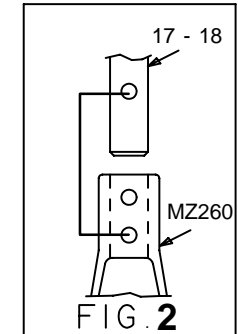
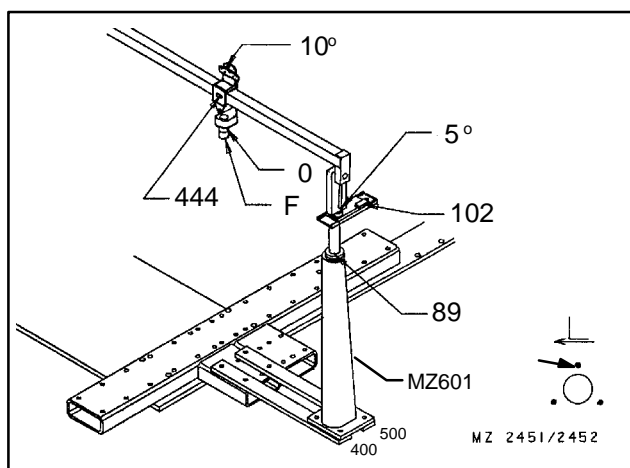
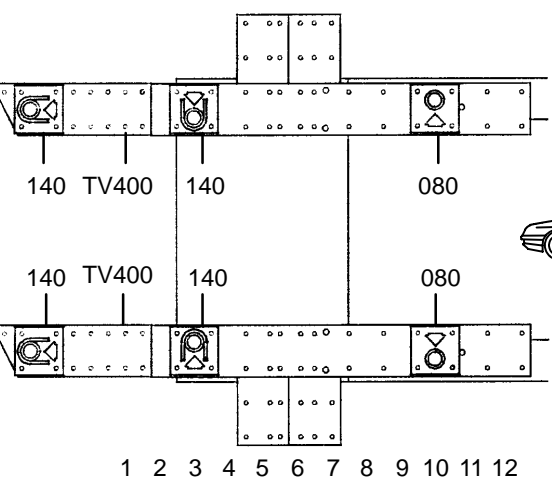
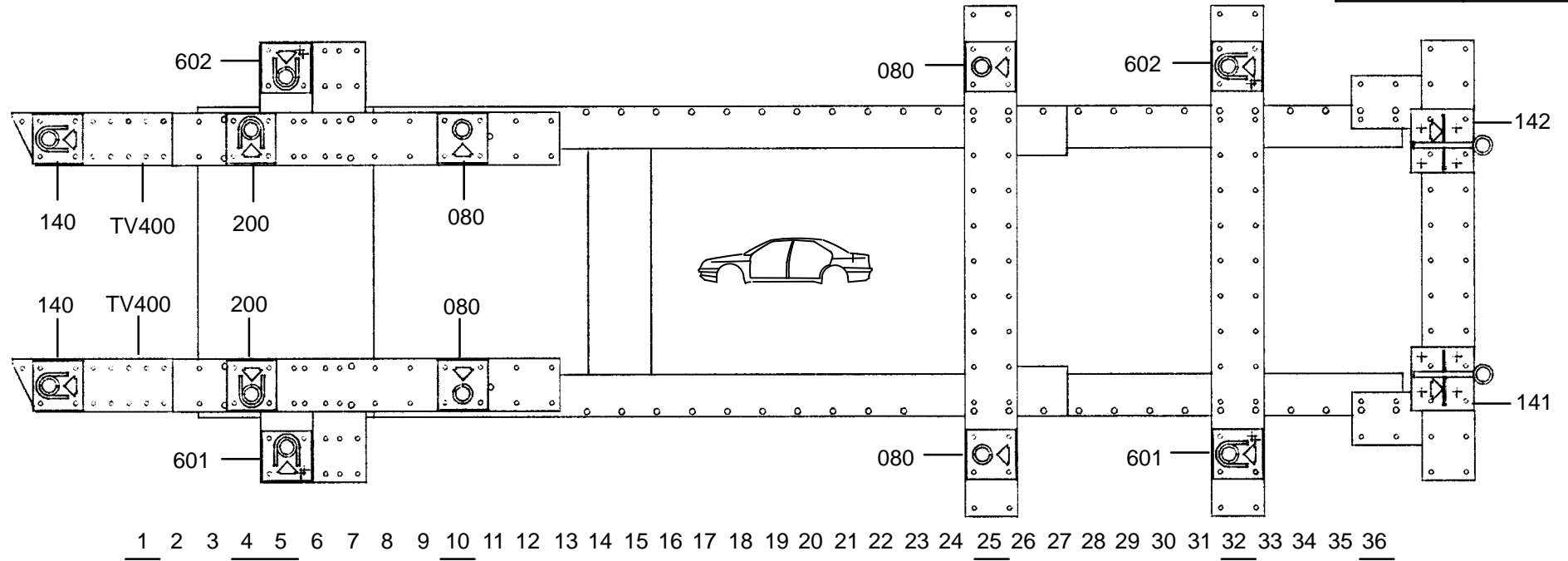

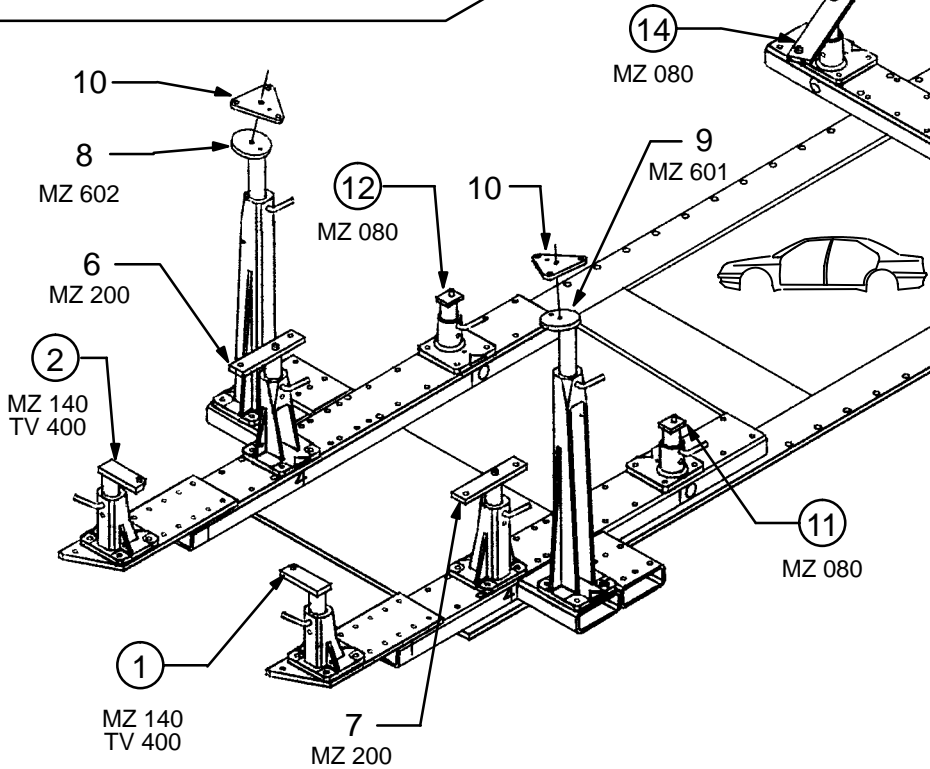
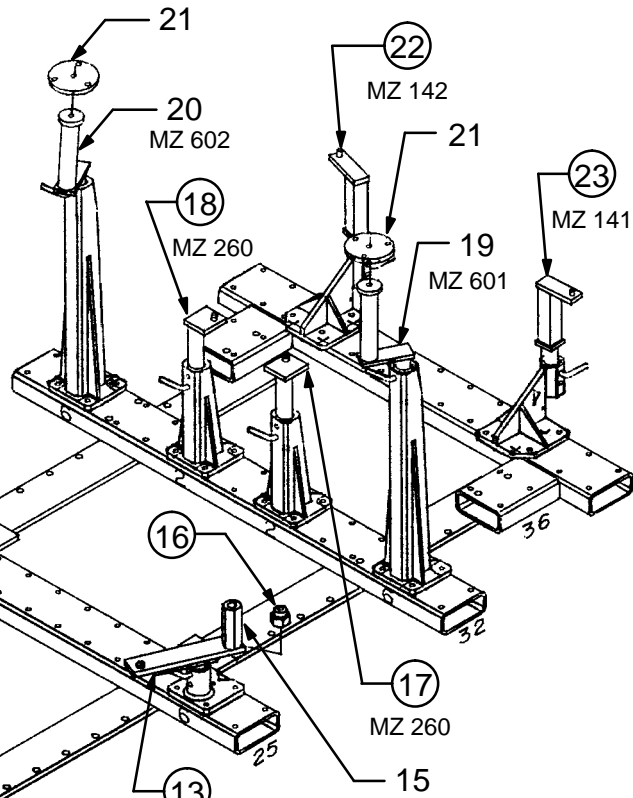
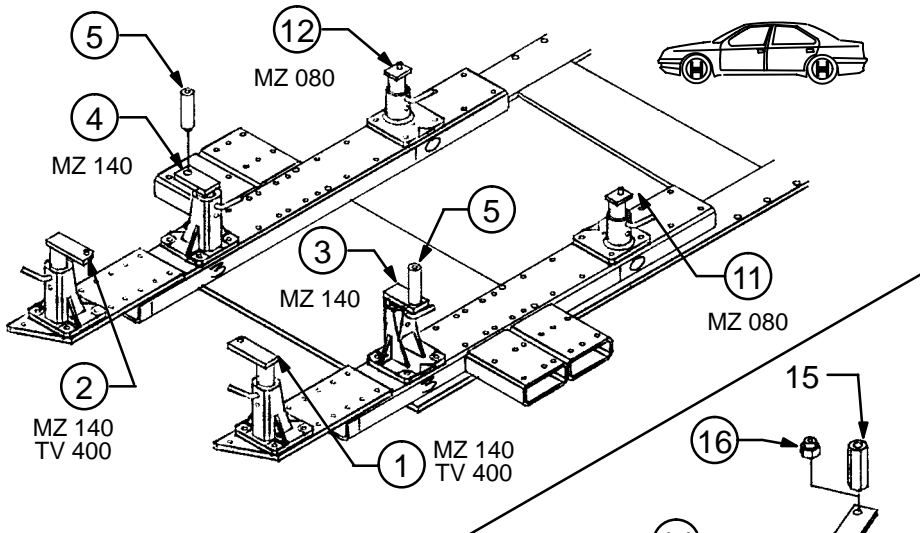

○ Avec ou sans mécanique
With or without mechanical elements
Con o senza parti meccaniche
Mit oder ohne Aggregate
Con ó sin mecanica desmontada

NISSAN

570.300

49Kg 14.01.91 410-D-33B

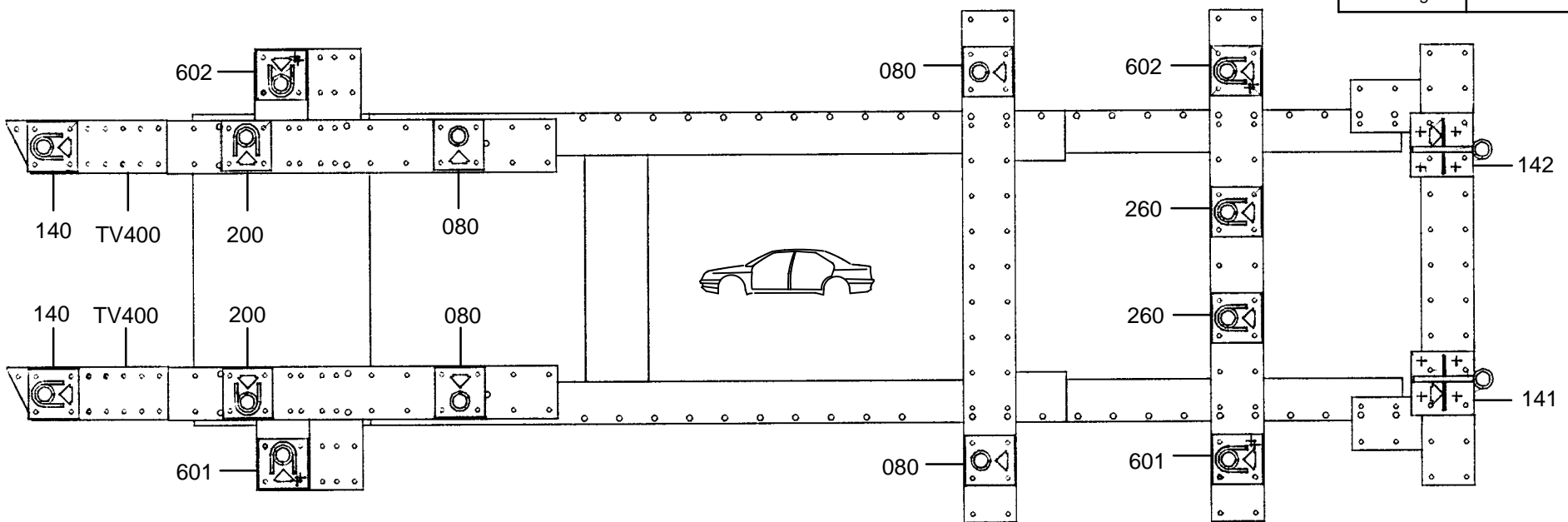

1 2 3 4 5 6 7 8 9 10 11 12 13 14 15 16 17 18 19 20 21 22 23 24 25 26 27 28 29 30 31 32 33 34 35 36

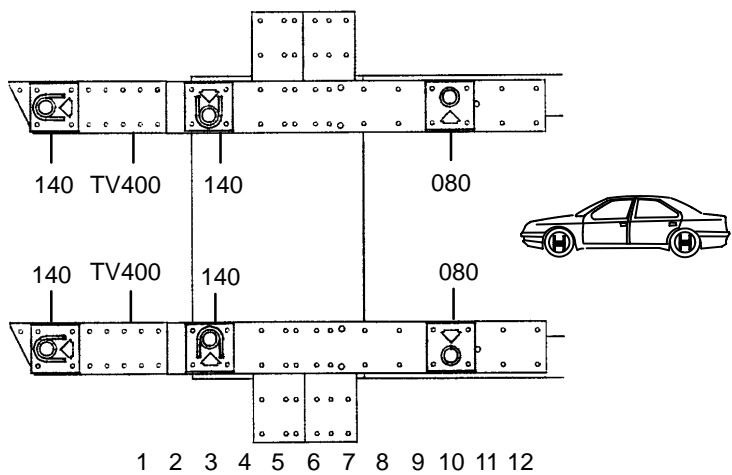

1 2 3 4 5 6 7 8 9 10 11 12

