

REP.	REFERENCE	PDS	NB	MZ
1	559.701	3,8	1	140
2	559.702	3,8	1	140
3	559.703	3,1	1	141
4	559.704	3,1	1	142
5	559.705	2,3	1	080
6	559.706	2,3	1	080
7	559.707	4,5	1	601
8	559.708	4,5	1	602
9	559.709	0,9	2	
10	559.710	1,7	1	140
11	559.711	1,7	1	140
12	559.712	2,5	1	200
13	559.713	2,5	1	200
14	559.714	2,8	1	080
15	559.715	2,8	1	080
16	559.716	1,2	2	
17	559.717	1,2	1	
18	559.718	1,2	1	
19	559.719	2,6	1	200/260
20	559.720	2,6	1	200/260
21	559.721	2,0	1	260
22	559.722	2,0	1	260
	V.25	0,1	2	
	B.38A	0,3	2	

	M12x25 M12x30	2 8
--	------------------	--------

	M8x100	2
--	--------	---

○ Avec ou sans mécanique
With or without mechanical elements
Con o senza parti meccaniche
Mit oder ohne aggregate
Con ó sin mecanica desmontada

RENAULT

559.300

59kg | 17-03-89 | 427-D-11A

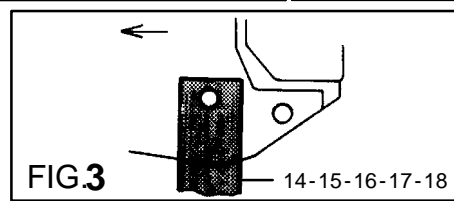
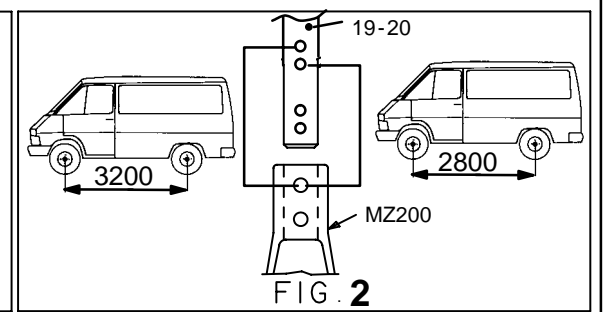
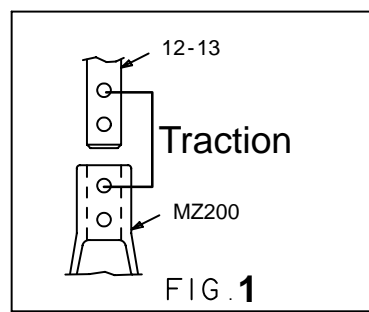
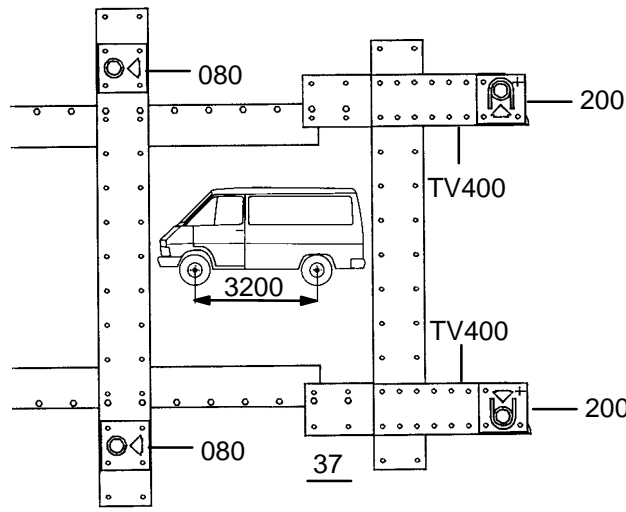
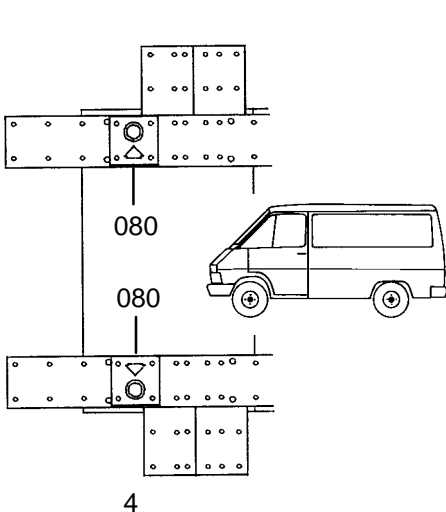
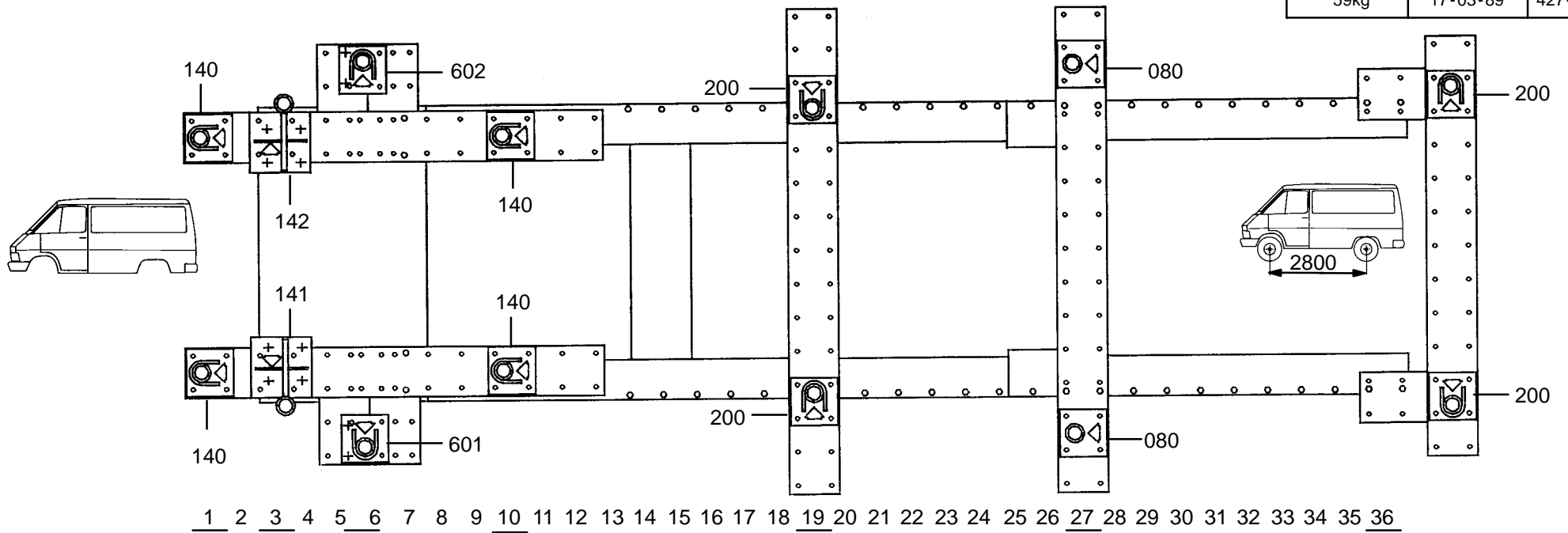

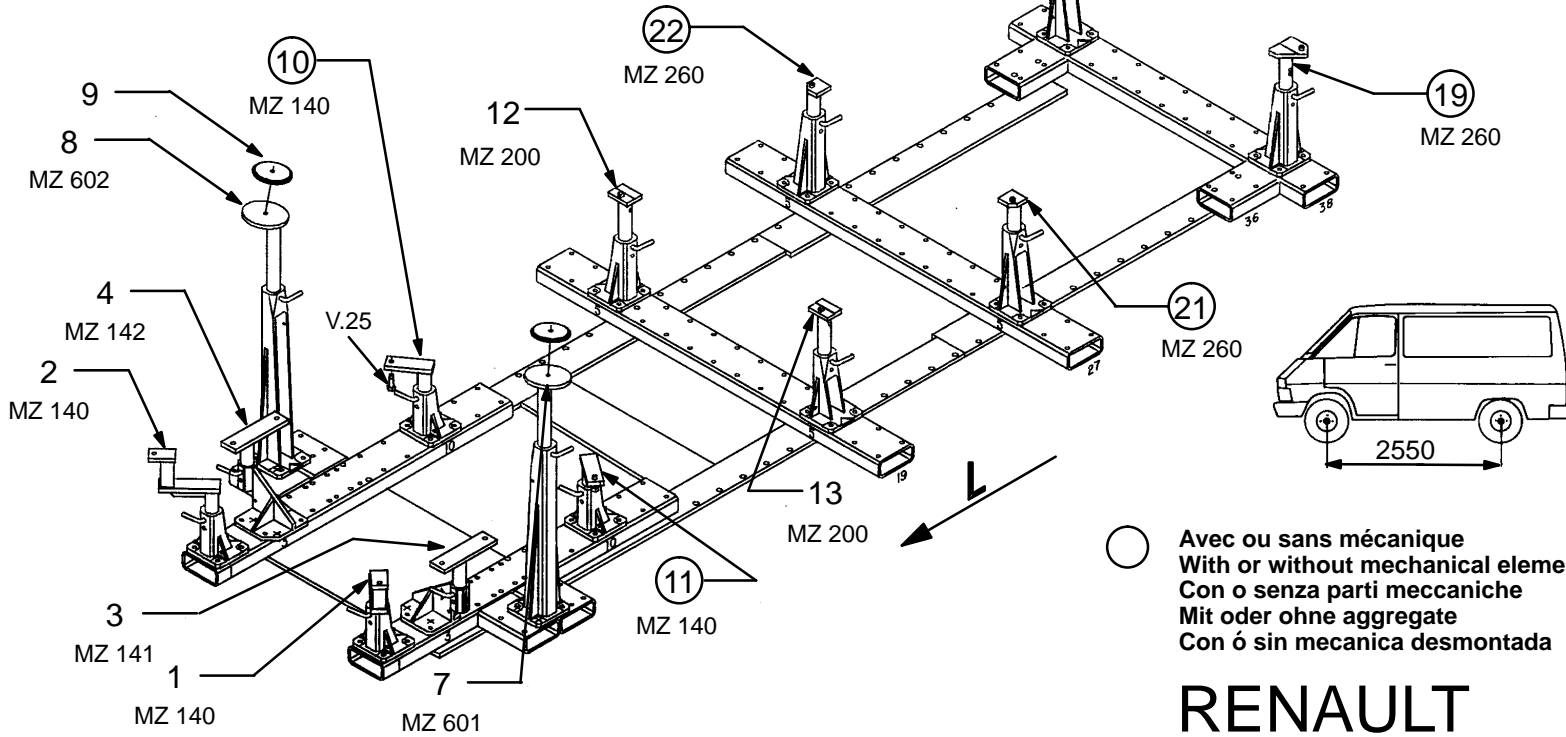
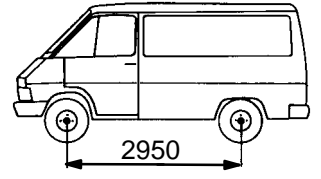
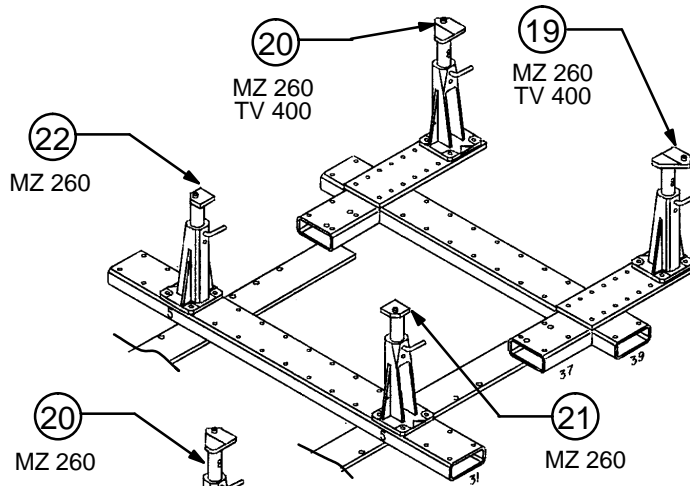
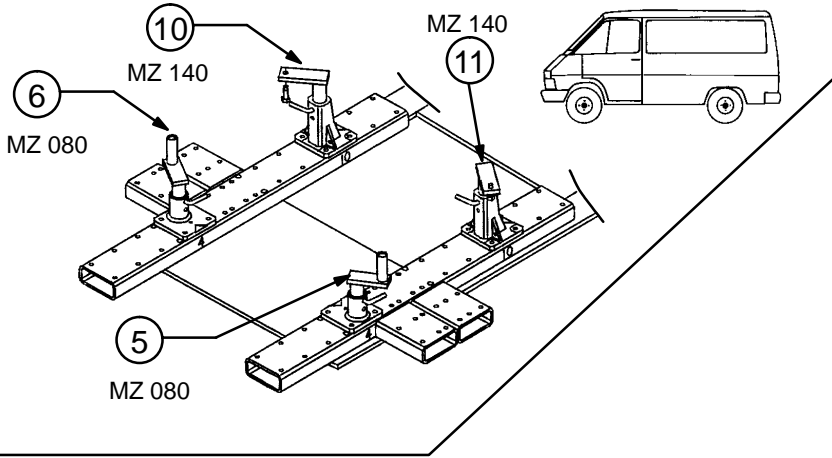

○ Avec ou sans mécanique
 With or without mechanical elements
 Con o senza parti meccaniche
 Mit oder ohne aggregate
 Con ó sin mecánica desmontada

REP.	REFERENCE	PDS	NB	MZ
1	559.701	3,8	1	140
2	559.702	3,8	1	140
3	559.703	3,1	1	141
4	559.704	3,1	1	142
5	559.705	2,3	1	080
6	559.706	2,3	1	080
7	559.707	4,5	1	601
8	559.708	4,5	1	602
9	559.709	0,9	2	
10	559.710	1,7	1	140
11	559.711	1,7	1	140
12	559.712	2,5	1	200
13	559.713	2,5	1	200
14	559.714	2,8	1	080
15	559.715	2,8	1	080
16	559.716	1,2	2	
17	559.717	1,2	1	
18	559.718	1,2	1	
19	559.719	2,6	1	200/260
20	559.720	2,6	1	200/260
21	559.721	2,0	1	260
22	559.722	2,0	1	260
	V.25	0,1	2	
	B.38A	0,3	2	

	M12x25 M12x30	2 8
--	------------------	--------

	M8x100	2
--	--------	---

RENAULT

559.300

59kg | 17-03-89 | 427-D-11B

