

- Modèle avec longerons renforcés
- Model with reinforced sidemembers
- Modell mit verstärkten Längsträgern
- Modello con longheroni rinforzati
- Modelo con largueros reforzados

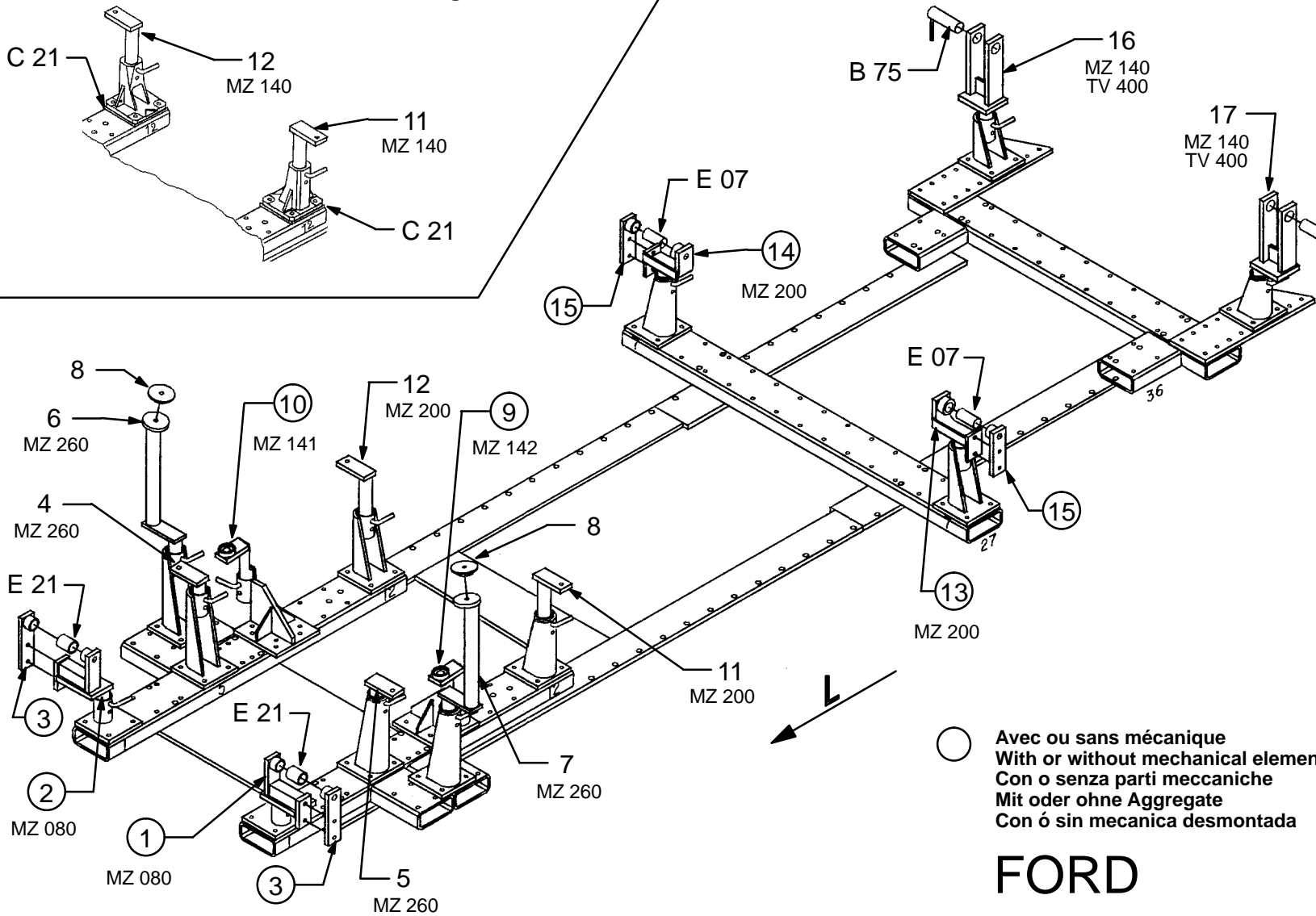
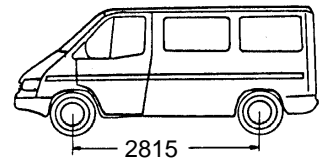

REP.	REFERENCE	PDS	NB	MZ
1	499.701	4,1	1	080
2	499.702	4,1	1	080
3	499.703	1,3	2	
4	499.704	2,0	1	260
5	499.705	2,0	1	260
6	499.706	3,4	1	260
7	499.707	3,4	1	260
8	499.708	0,5	2	
9	499.709	3,2	1	142
10	499.710	3,2	1	141
11	499.711	3,0	1	200
12	499.712	3,0	1	200
13	499.713	3,5	1	200
14	499.714	3,5	1	200
15	499.715	1,2	2	
16	499.716	5,6	1	140
17	499.717	5,6	1	140
	B 75	1,0	2	
	E 07	0,1	2	
	E 21	0,1	2	
	C 21	1,8	2	

	M12x30	10
	M12x90	2
	M12x110	2
	M12x150	2

○ Avec ou sans mécanique  
 With or without mechanical elements  
 Con o senza parti meccaniche  
 Mit oder ohne Aggregate  
 Con ó sin mecanica desmontada

**FORD**

**499.310**

63 Kg	15.05.90	412-D-12C
-------	----------	-----------

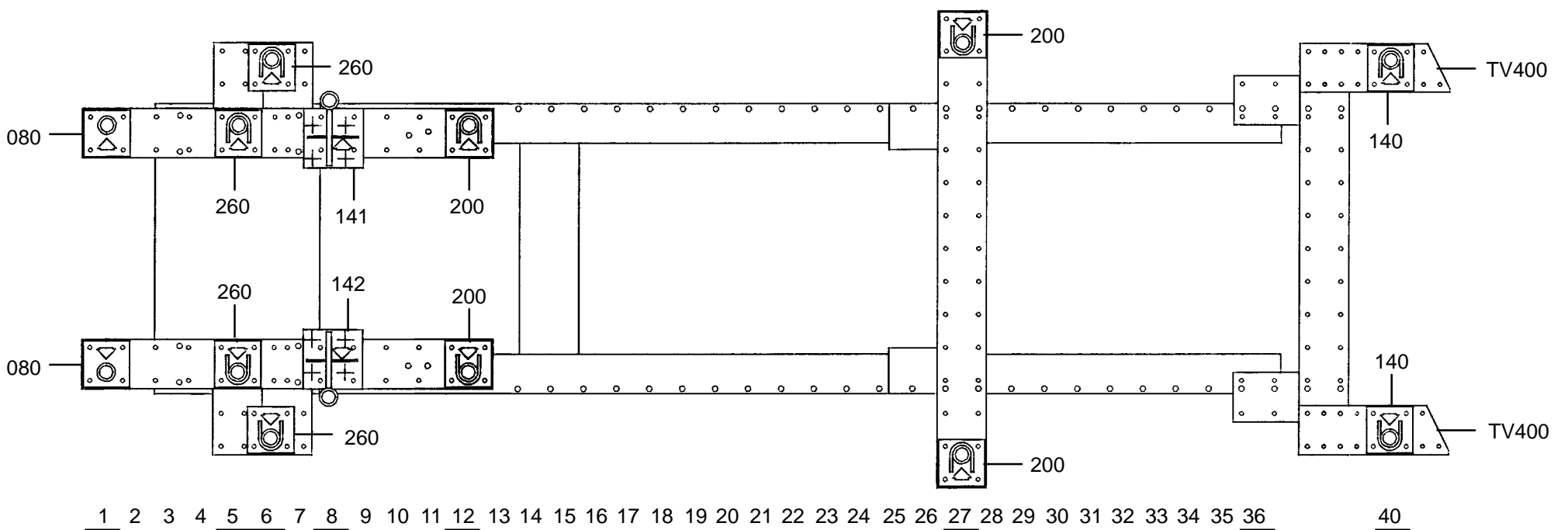

1 2 3 4 5 6 7 8 9 10 11 12 13 14 15 16 17 18 19 20 21 22 23 24 25 26 27 28 29 30 31 32 33 34 35 36 40

- Modèle avec longerons renforcés
- Model with reinforced sidemembers
- Modell mit verstärkten Längsträgern
- Modello con longheroni rinforzati
- Modelo con largueros reforzados

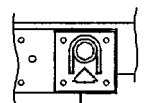

140 + C 21

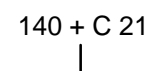

140 + C 21

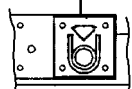

12

