

○ Avec ou sans mécanique
 With or without mechanical elements
 Con o senza parti meccaniche
 Mit oder ohne Aggregate
 Con ó sin mecanica desmontada

REP.	REFERENCE	PDS	NB	MZ
1	2114.7001	2,7	1	141
2	2114.7002	2,7	1	142
3	2114.7003	2,4	1	140/080
4	2114.7004	2,4	1	140/080
5	2114.7005	0,1	2	
6	2114.7006	2,5	1	260
7	2114.7007	2,5	1	260
8	2114.7008	2,6	1	602
9	2114.7009	2,6	1	601
10	2114.7010	0,6	2	
11	2114.7011	1,9	1	080
12	2114.7012	1,9	1	080
13	2114.7013	0,2	2	
14	2114.7014	4,9	1	
15	2114.7015	4,9	1	
16	2114.7016	0,9	2	
17	2114.7017	0,8	2	
18	2114.7018	1,7	1	200
19	2114.7019	2,9	1	140
20	2114.7020	2,9	1	140
22	2114.7022	0,2	2	
23	2114.7023	3,2	1	200
24	2114.7024	3,2	1	200
25	2114.7025	1,8	1	140/080
26	2114.7026	1,8	1	140/080
27	2114.7027	0,1	2	
28	2114.7028	2,1	1	602
29	2114.7029	2,1	1	601
30	2114.7030	2,5	1	260/200
31	2114.7031	2,5	1	260/200
32	2114.7032	0,1	2	
33	2114.7033	2,3	1	200
34	2114.7034	2,3	1	200
35	2114.7035	2,6	1	260
36	2114.7036	2,6	1	260
	B76	0,1	4	

M 8-25	6
M 8-40	4
M 8-60	1
M 12-25	2
M 12-70	2
M 12-110	2
M 12-120	2
M 14-110	2
M 14-120	4
M 14-150	4
M 14-160	2
M 14-180	2
M 14-200	2

OPEL

2114.300

80 Kg 07.06.2007 422-D-29A

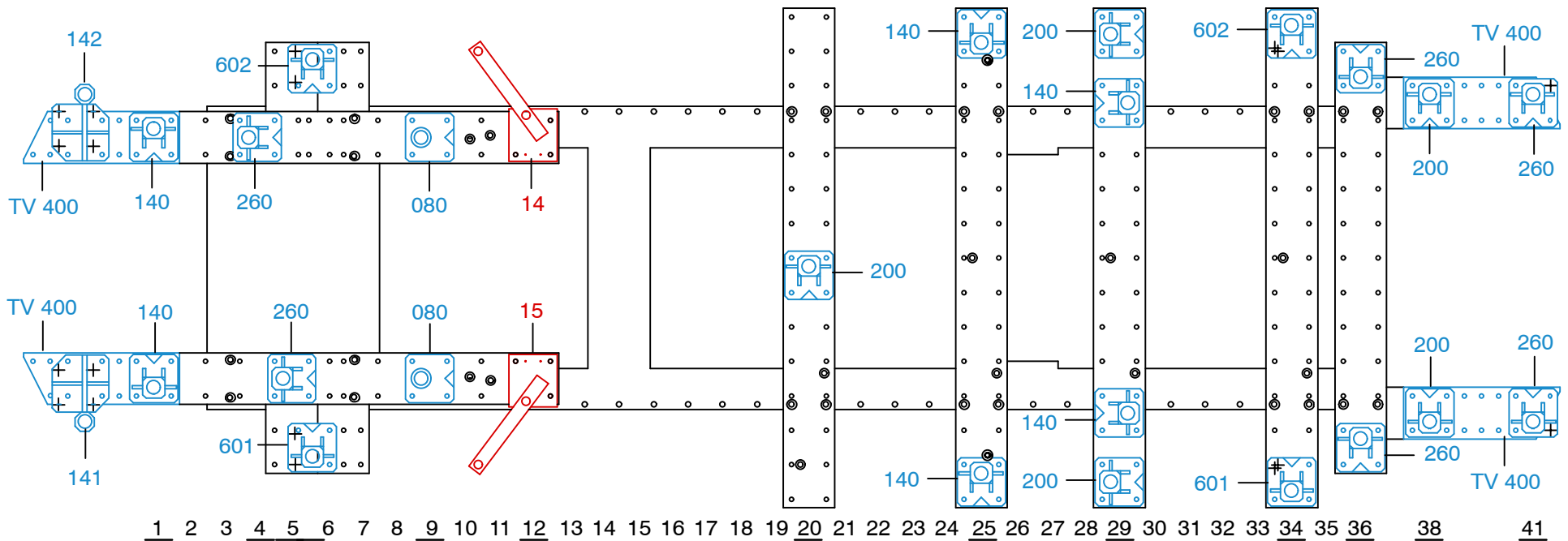

<p>Réparation Rebuilding Riconstruzione Instandsetzung Reparación</p> <p>Contrôle Checking Controllo Überprüfung Control</p> <p>FIG. 2</p>	<p>11 - 12 + 13</p> <p>MZ 080</p> <p>FIG. 3</p>	<p>18</p> <p>MZ 200</p> <p>FIG. 4</p>	<p>19 - 20 + 22</p> <p>MZ 140</p> <p>FIG. 5</p>	<p>23 - 24</p> <p>MZ 200</p> <p>FIG. 6</p>	<p>25 - 26 + 27</p> <p>MZ 140</p> <p>FIG. 7</p>
<p>3 - 4 + 5</p> <p>MZ 140 + TV400</p> <p>FIG. 1</p>	<p>28 - 29</p> <p>MZ 601 / 602</p> <p>FIG. 8</p>	<p>30 - 31 + 32</p> <p>MZ 260</p> <p>FIG. 9</p>	<p>33 - 34</p> <p>MZ 200 + TV400</p> <p>FIG. 10</p>	<p>35 - 36</p> <p>MZ 260 + TV400</p> <p>FIG. 11</p>	

2114.300-RVA3-1 00

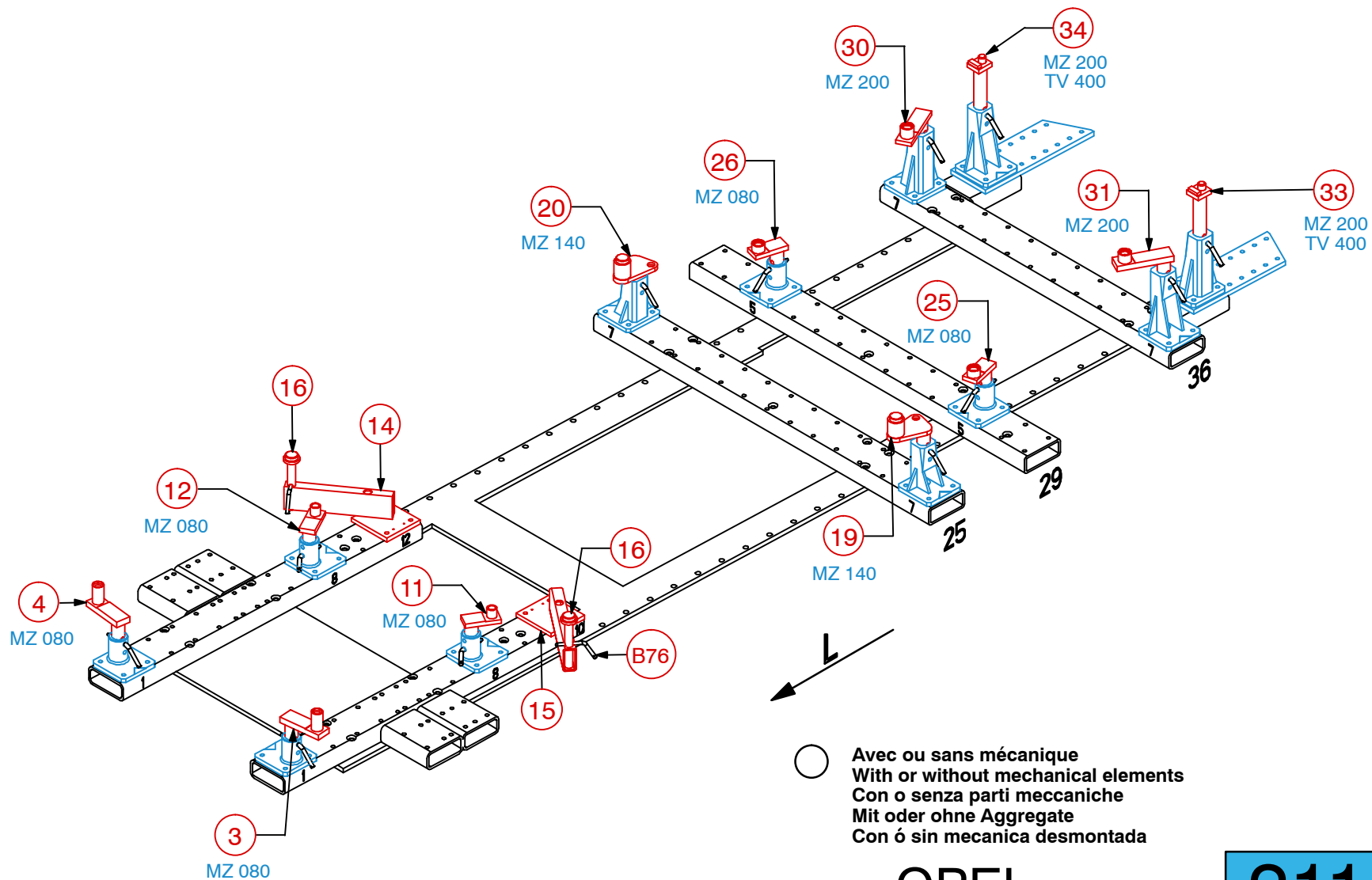
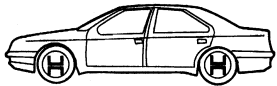

OPEL

2114.300		
80 Kg	07.06.2007	422-D-29B

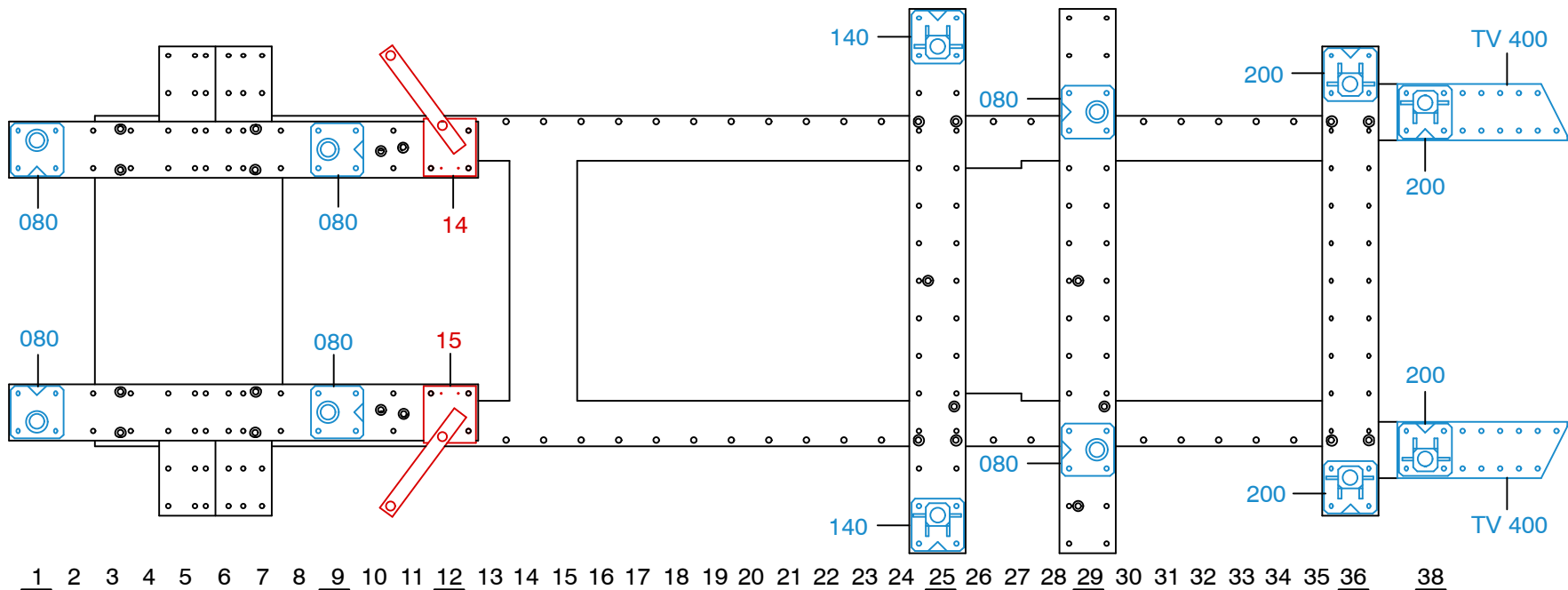

1 2 3 4 5 6 7 8 9 10 11 12 13 14 15 16 17 18 19 20 21 22 23 24 25 26 27 28 29 30 31 32 33 34 35 36 38

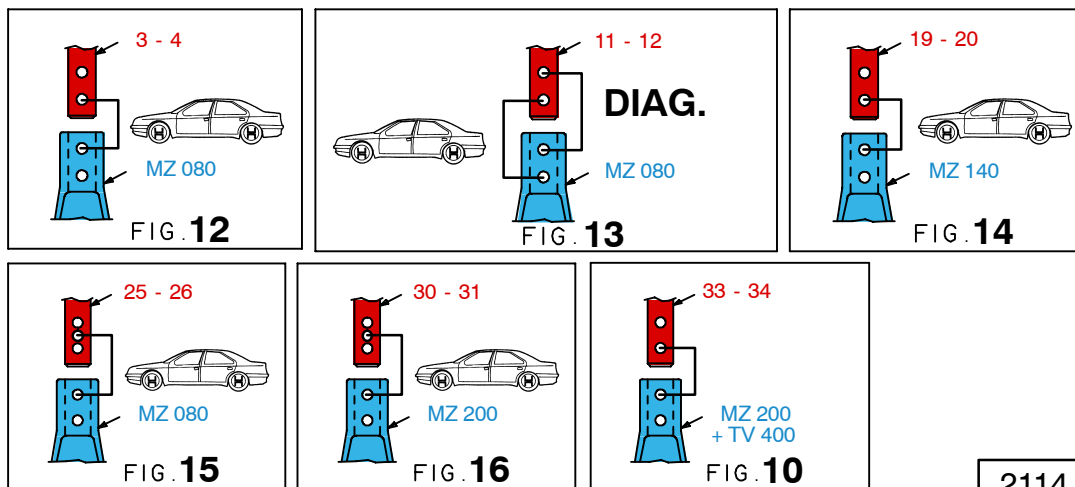
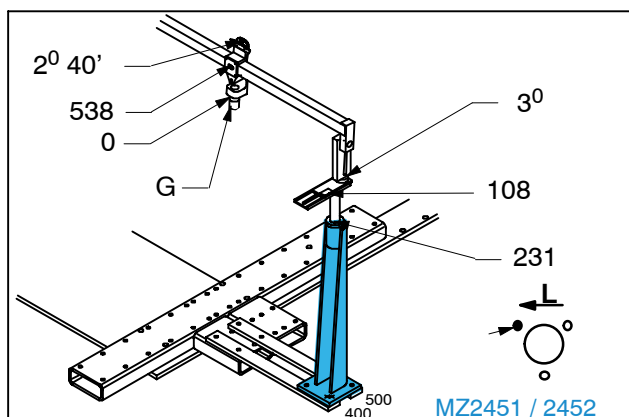

2114.300-RVA3-1 | 00