

REP.	REFERENCE	PDS	NB	MZ
1	2103.7001	3,2	1	141
2	2103.7002	3,2	1	142
3	2103.7003	2,2	1	
4	2103.7004	2,2	1	
5	2103.7005	2,4	1	260
6	2103.7006	2,7	1	260
7	2103.7007	3,1	1	601
8	2103.7008	3,1	1	602
9	2103.7009	1,4	1	260/080
10	2103.7010	1,4	1	260/080
11	2103.7011	0,3	4	
12	2103.7012	0,7	2	
13	2103.7013	2,9	1	080
14	2103.7014	2,9	1	080
15	2103.7015	4,5	1	
16	2103.7016	4,5	1	
17	2103.7017	1,0	2	
18	2103.7018	1,8	1	080
19	2103.7019	1,8	1	080
20	2103.7020	2,8	1	140
21	2103.7021	2,8	1	140
22	2103.7022	2,2	1	200
23	2103.7023	2,2	1	200
24	2103.7024	2,9	1	602
25	2103.7025	2,9	1	601
26	2103.7026	1,8	1	260
27	2103.7027	1,8	1	260
28	2103.7028	2,9	1	200
29	2103.7029	2,9	1	200
30	2103.7030	0,4	2	
31	2103.7031	0,3	2	
	V21	0,1	2	
	B76	0,1	2	

M 8-30	4
M 8-35	2
M 10-30	8
M 10-40	1
M 12-20	4
M 12-25	2
M 12-40	1
M 12-60	2
M 12-70	2
M 12-80	2
M 12-90	4
M 12-110	2

	M 12	2
--	------	---

○ Avec ou sans mécanique  
 With or without mechanical elements  
 Con o senza parti meccaniche  
 Mit oder ohne Aggregate  
 Con ó sin mecanica desmontada

## OPEL

# 2103.300

77 Kg    20.09.2006    422-D-28A

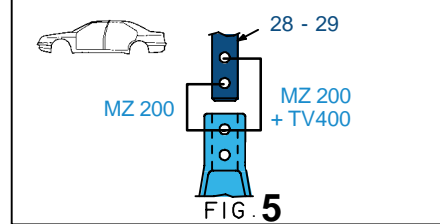
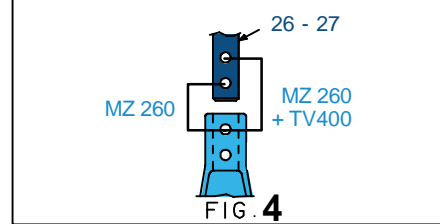
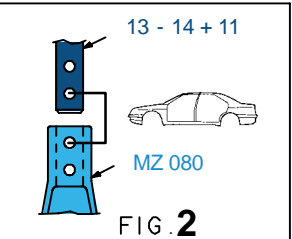
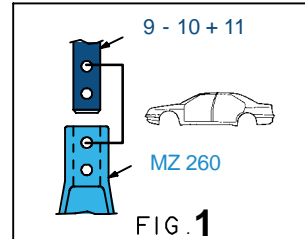
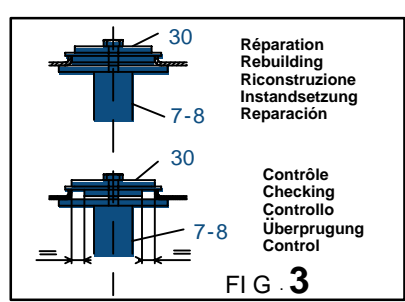
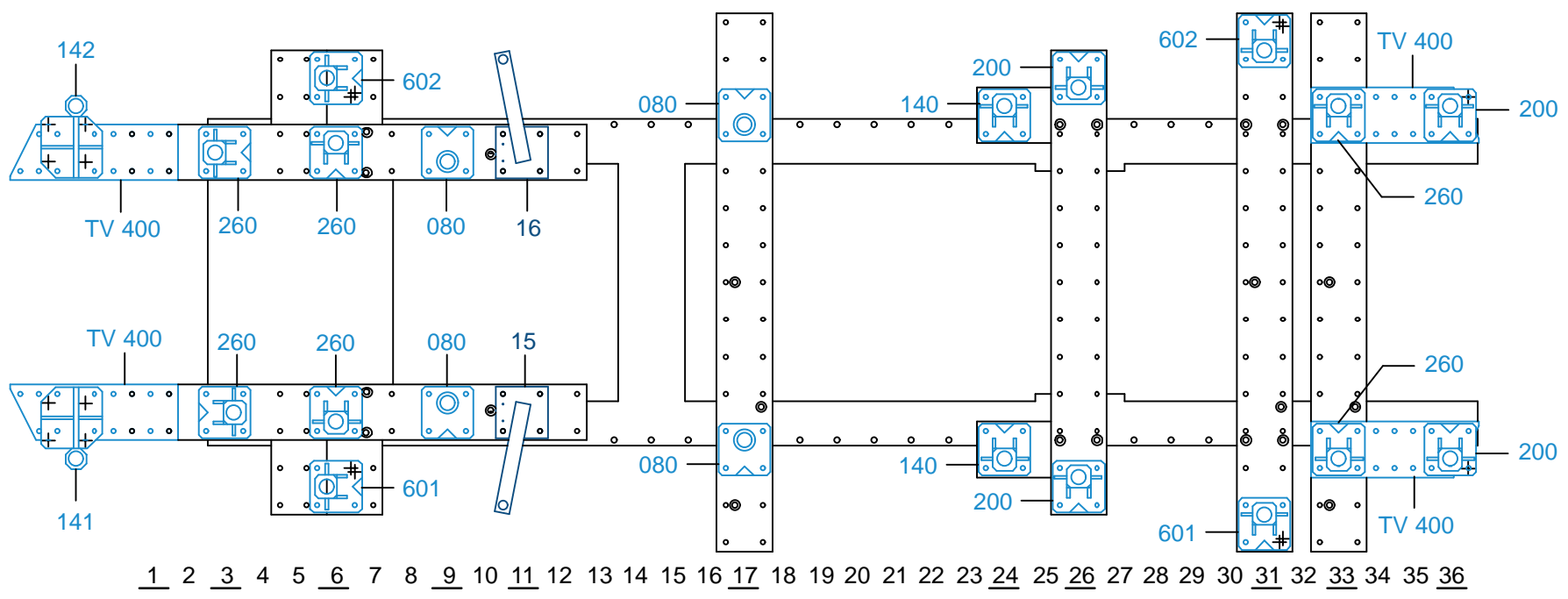

2103.300-RVA3-1 00

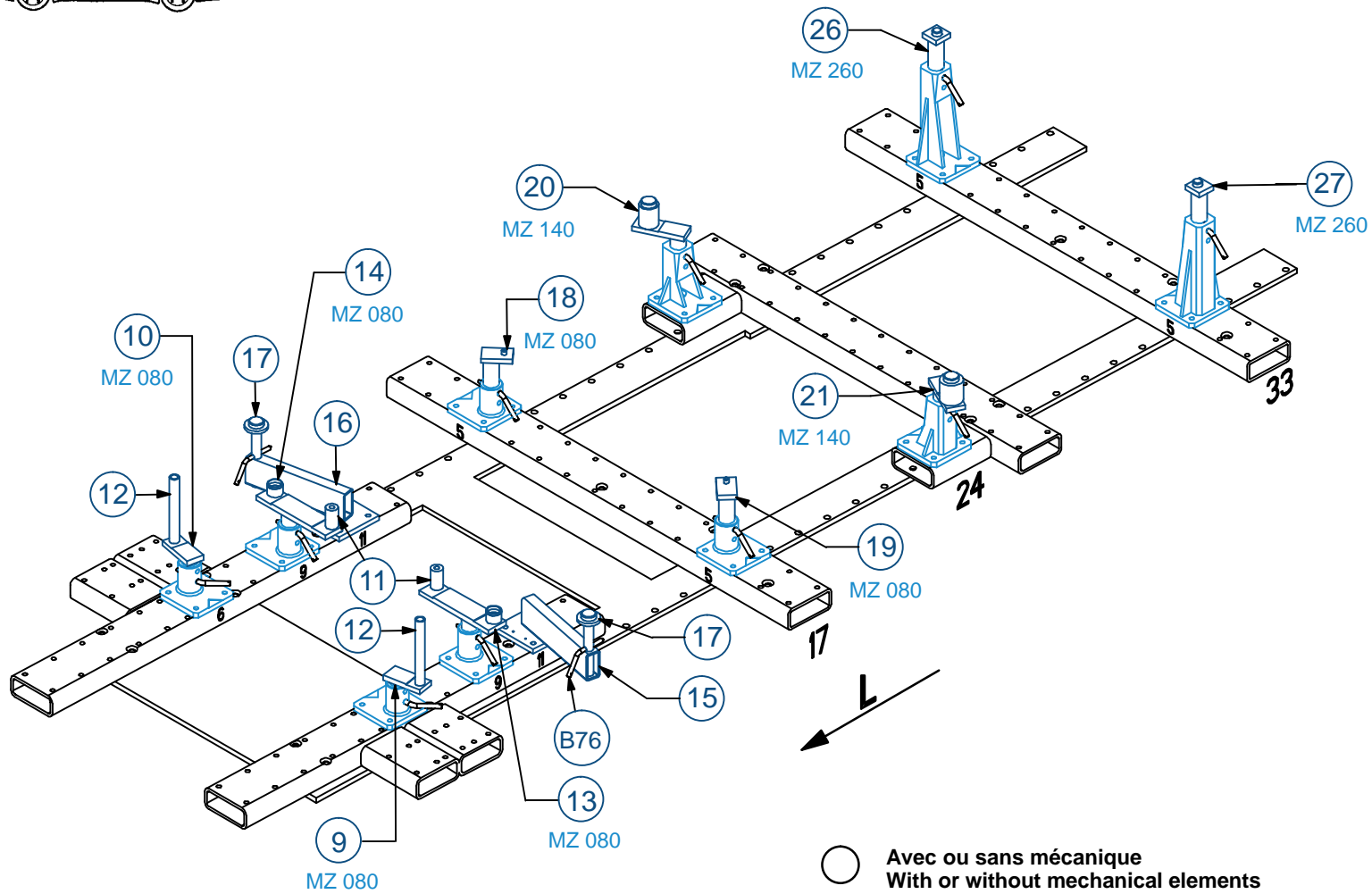
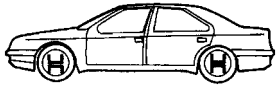

○ Avec ou sans mécanique  
 With or without mechanical elements  
 Con o senza parti meccaniche  
 Mit oder ohne Aggregate  
 Con ó sin mecánica desmontada

**OPEL**

**2103.300**

77 Kg    20.09.2006    422-D-28B

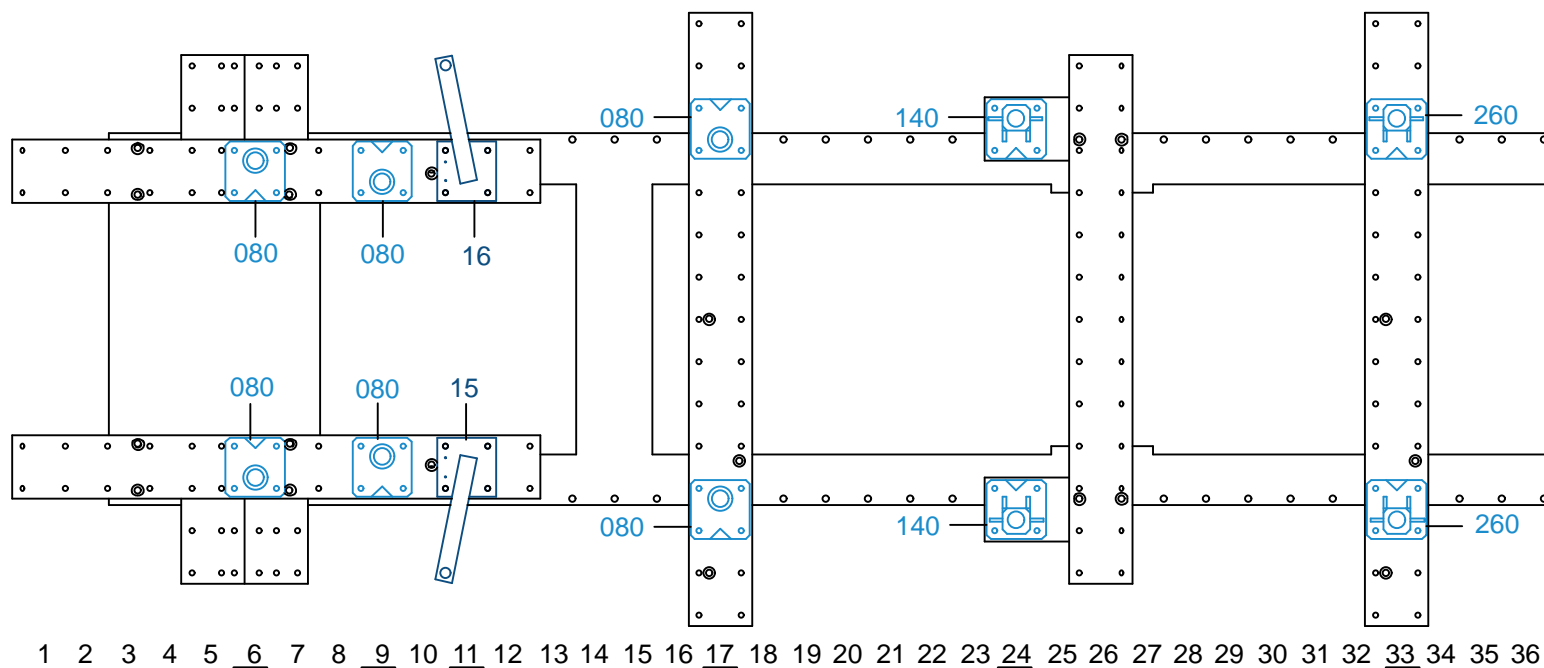

1 2 3 4 5 6 7 8 9 10 11 12 13 14 15 16 17 18 19 20 21 22 23 24 25 26 27 28 29 30 31 32 33 34 35 36

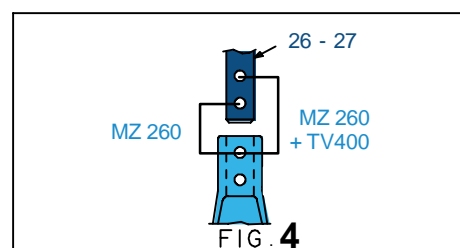
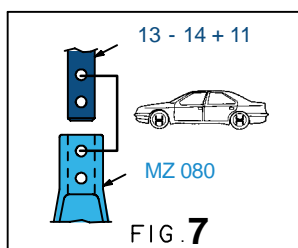
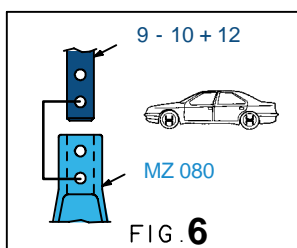

- Lors du repositionnement de la fixation supérieure de la façade avant, ne pas utiliser les cales A.
- When repositioning the front panel upper fixing, do not use plates A.
- Beim wiedereinsetzen der oberen Befestigung der Frontverkleidung, die Platten A nicht verwenden.
- Durante ricollocamento del fissaggio superiore del pannello frontale, non utilizzare le placche A.
- Al momento de la colocación de la fijación superior de la fachada delantera, no utilizar las placcas A.

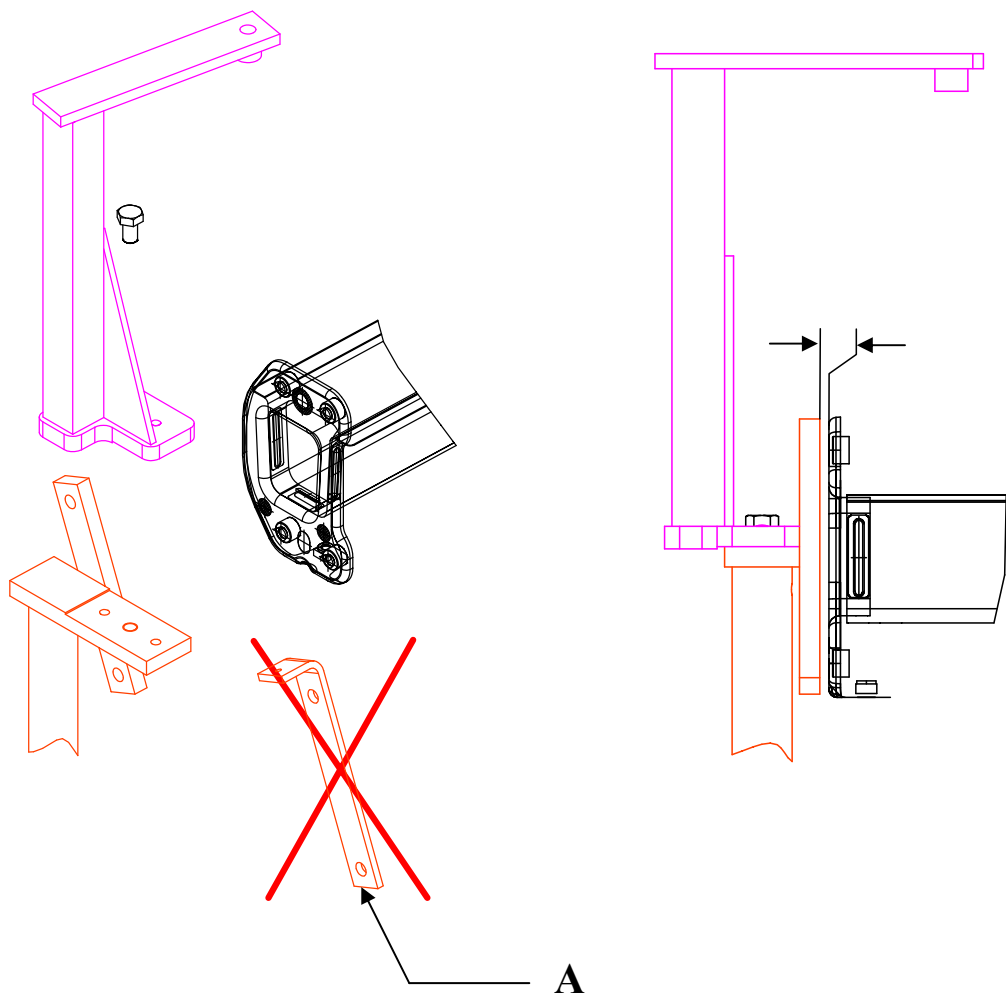

- Lors du repositionnement de l'extrémité du longeron, utiliser les cales A.
- When repositioning of the sidemember end, use plates A.
- Beim wiedereinsetzen des Längstraversenendes, die Platten A verwenden.
- Durante ricollocamento dell'estremità del longherone, utilizzare le placche A.
- Al momento de la colocación de la extremidad del larguero, utilizar las placcas A.

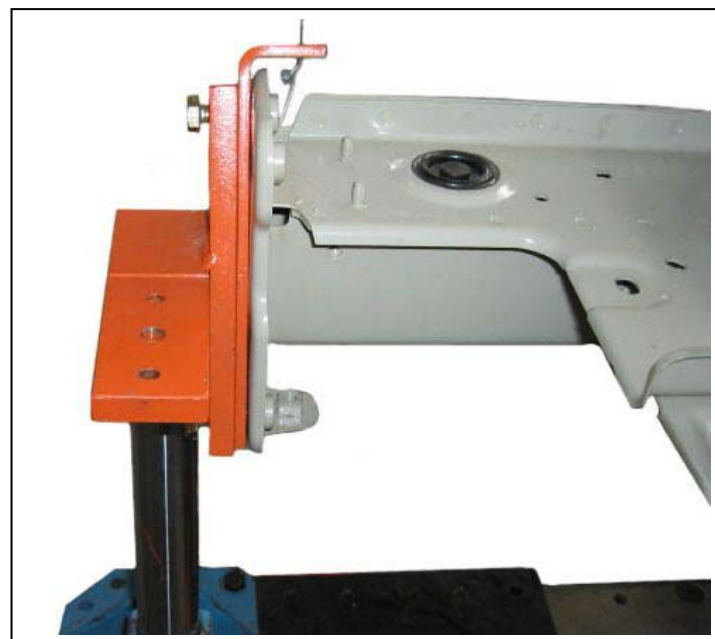
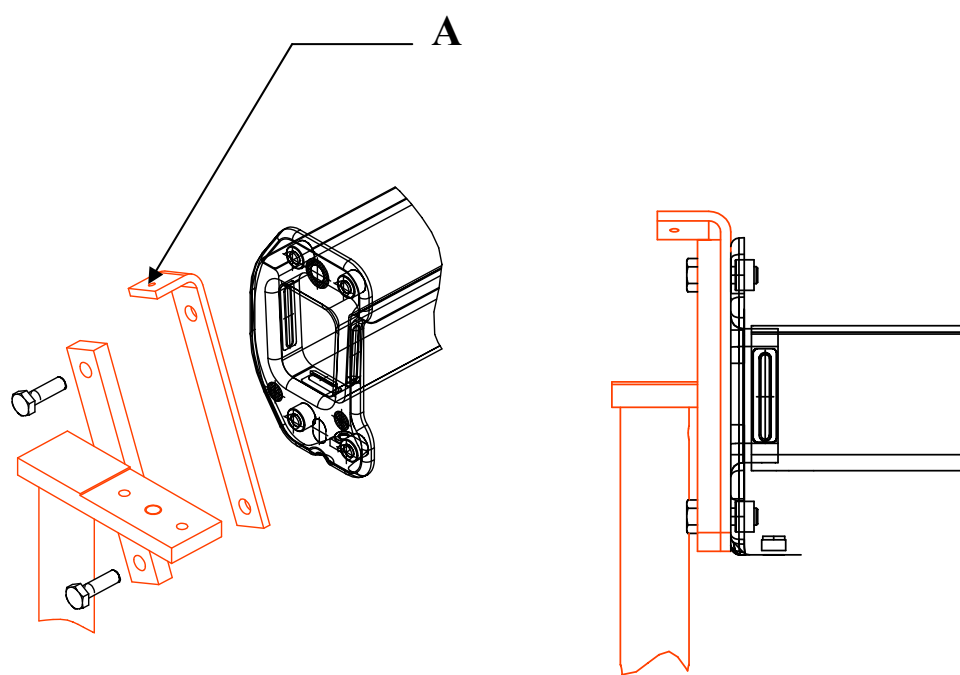

19/09/06

FIG.EXTLAV-RA3-1

00