

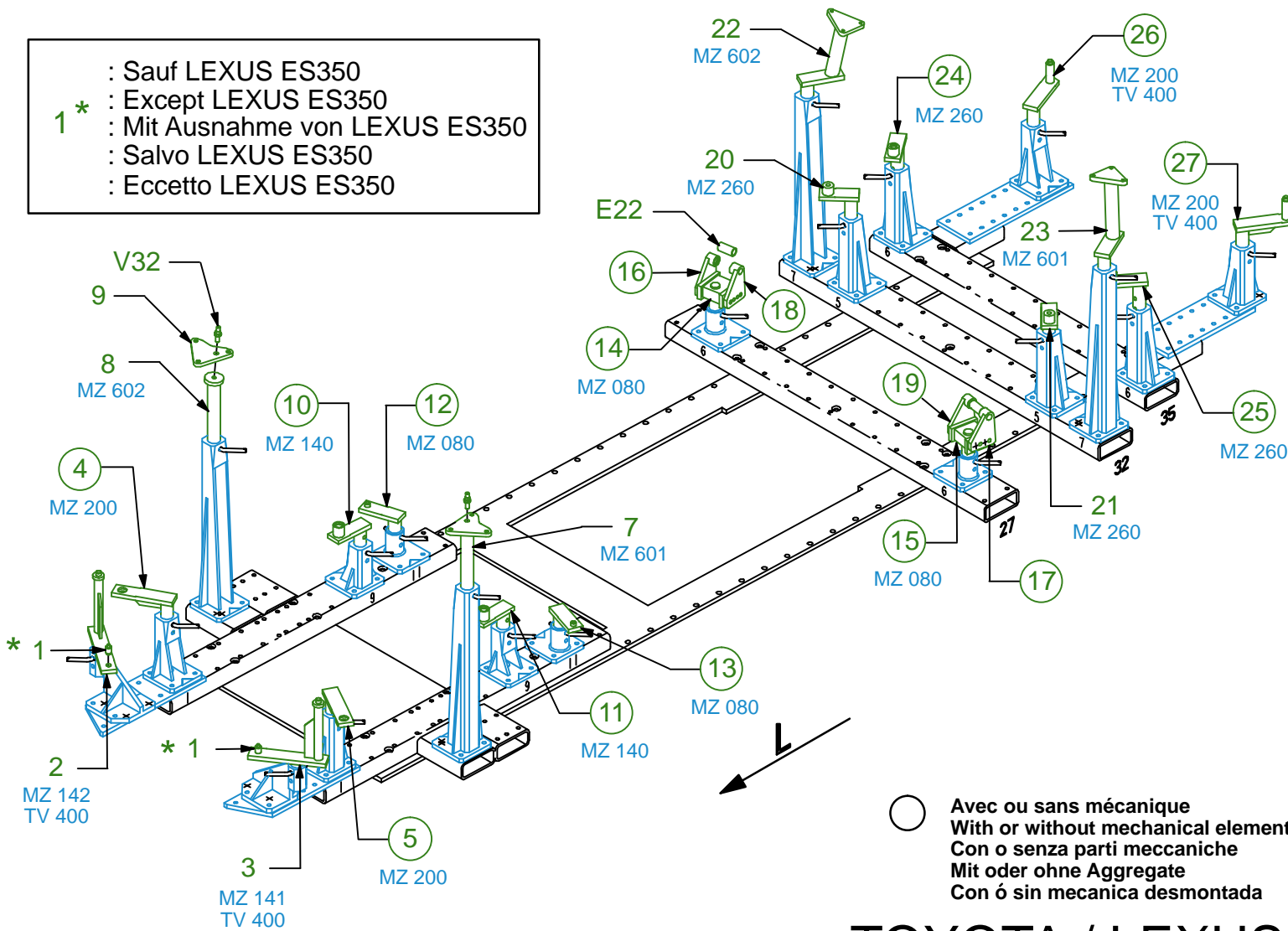

: Sauf LEXUS ES350
 1* : Except LEXUS ES350
 : Mit Ausnahme von LEXUS ES350
 : Salvo LEXUS ES350
 : Eccetto LEXUS ES350



REP.	REFERENCE	PDS	NB	MZ
1	2100.7001	0,05	2	
2	2100.7002	2,8	1	142
3	2100.7003	2,8	1	141
4	2100.7004	2,3	1	200/080
5	2100.7005	2,3	1	200/080
6	2100.7006	0,1	2	
7	2100.7007	1,5	1	601
8	2100.7008	1,5	1	602
9	2100.7009	1,0	2	
10	2100.7010	1,9	1	140/080
11	2100.7011	1,9	1	140/080
12	2100.7012	1,8	1	080
13	2100.7013	1,8	1	080
14	2100.7014	2,7	1	080
15	2100.7015	2,7	1	080
16	2100.7016	0,9	1	
17	2100.7017	0,9	1	
18	2100.7018	0,9	1	
19	2100.7019	0,9	1	
20	2100.7020	2,2	1	260
21	2100.7021	2,2	1	260
22	2100.7022	3,2	1	602
23	2100.7023	3,2	1	601
24	2100.7024	2,4	1	260
25	2100.7025	2,4	1	260
26	2100.7026	2,7	1	200
27	2100.7027	2,7	1	200
29	2100.7029	0,1	4	
E22		0,1	2	
V32		0,1	2	

M 8-20	6
M 12-20	8
M 12-25	8
M 12x1,25-70	4
M 12x1,25-130	2
M 16x1,50-50	2
M 16x1,50-110	2
M 16x1,50-170	2
M 16x1,50-180	2

○ Avec ou sans mécanique
 With or without mechanical elements
 Con o senza parti meccaniche
 Mit oder ohne Aggregate
 Con ó sin mecanica desmontada

TOYOTA / LEXUS

2100.300

56 Kg 12.02.2007 434-D-85A

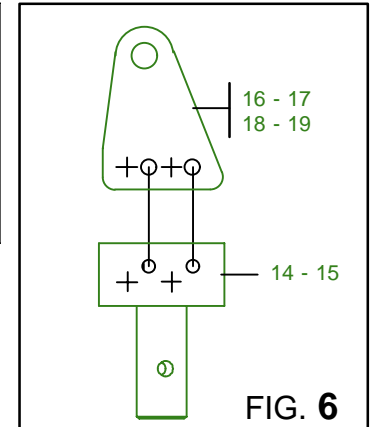
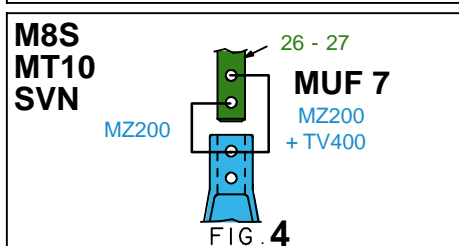
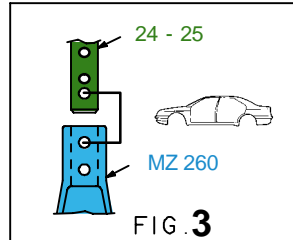
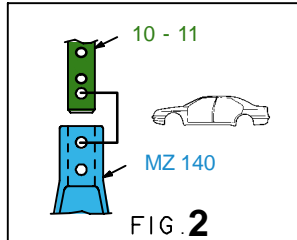
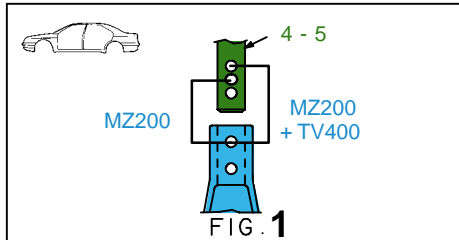
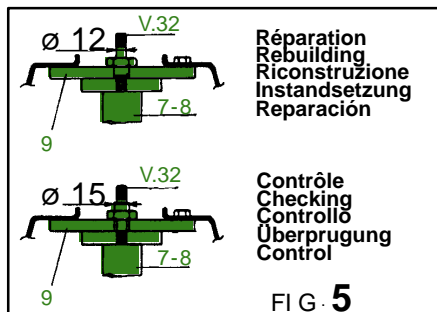
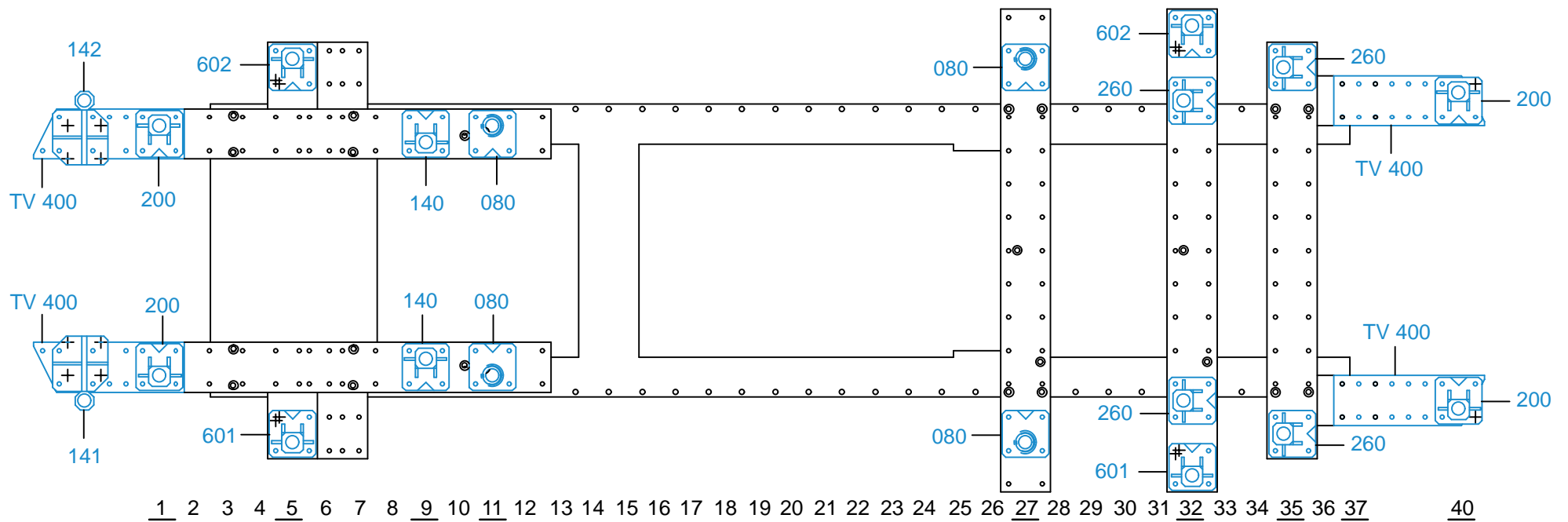

2100.300-RVA3-1 01

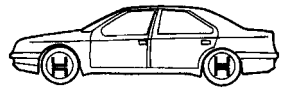

2WD

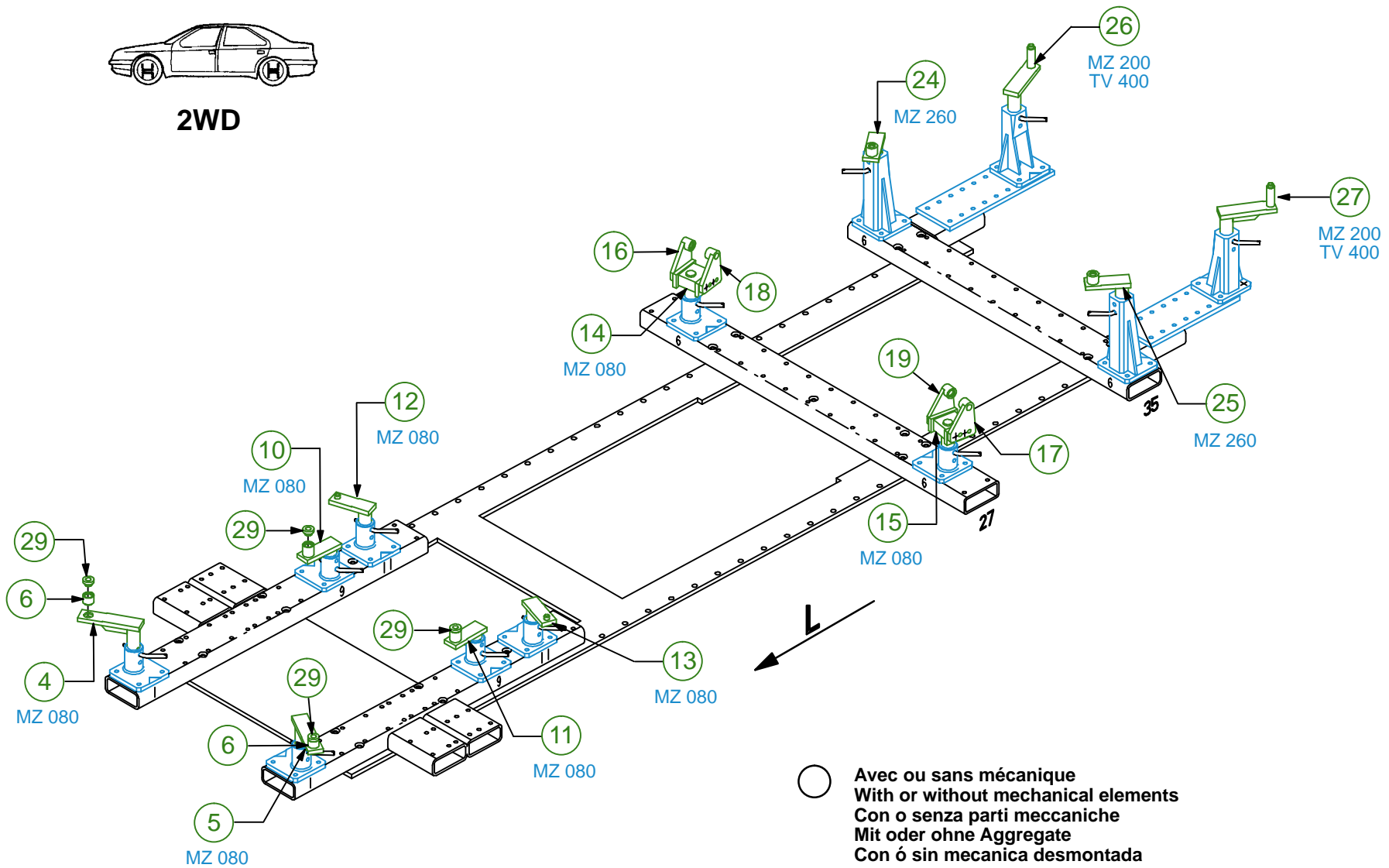

TOYOTA / LEXUS

2100.300

56 Kg | 21.12.2006 | 434-D-85B

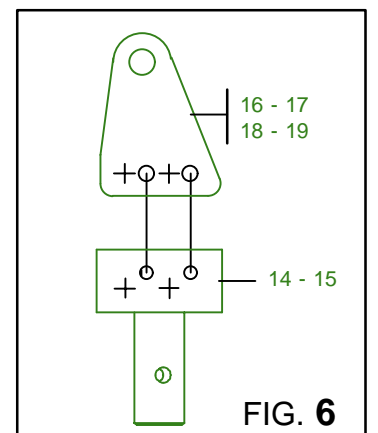
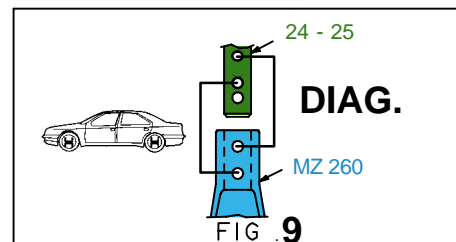
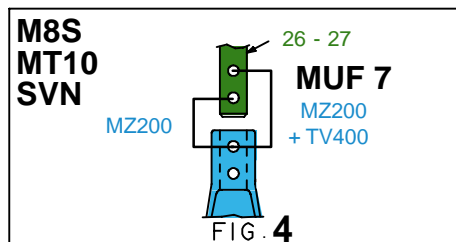
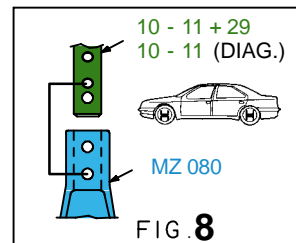
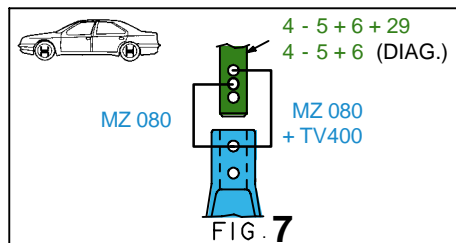
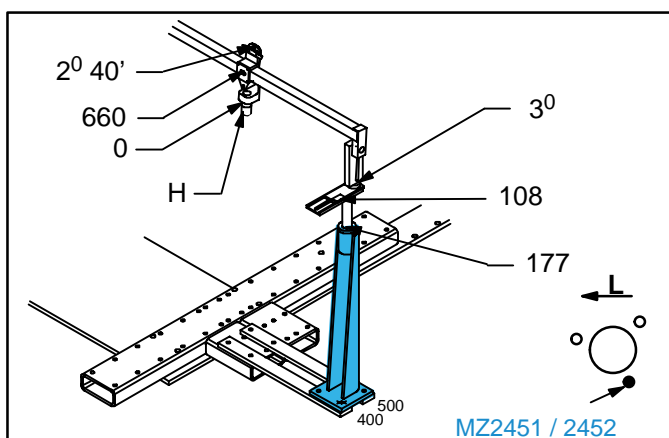
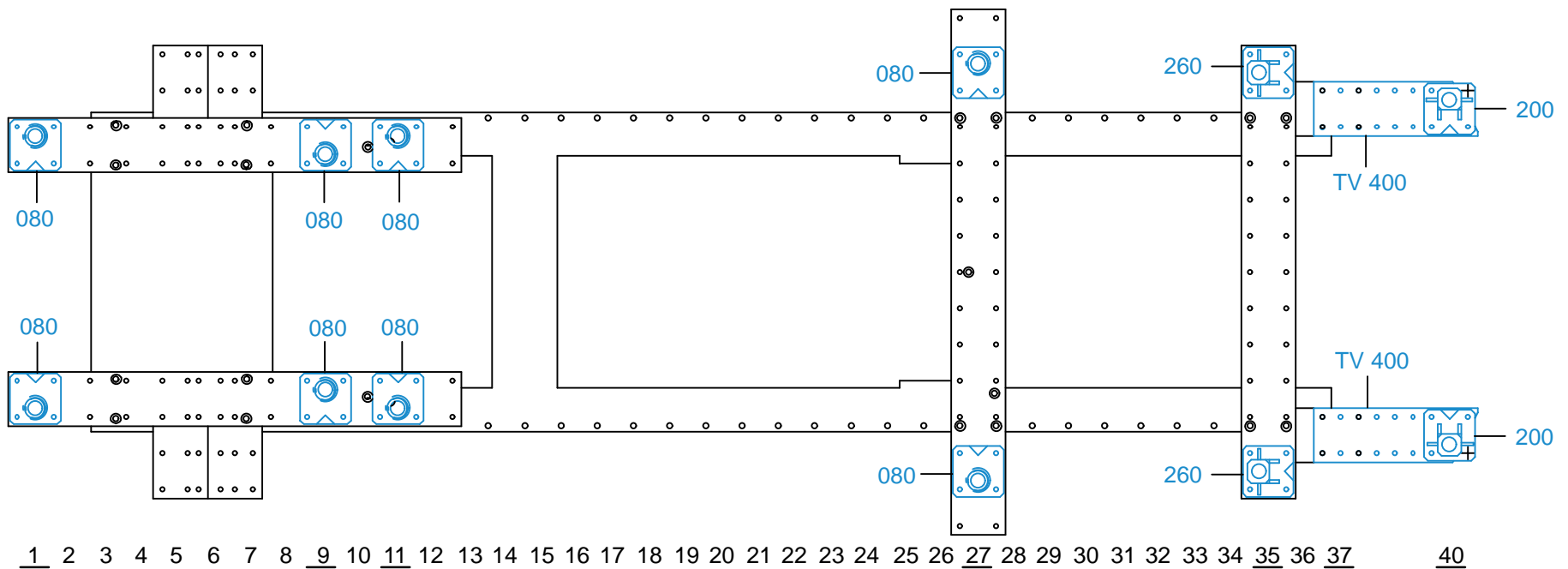

2100.300-RVA3-1 | 01