

REP.	REFERENCE	PDS	NB	MZ
1	2041.7001	3,1	1	142
2	2041.7002	3,1	1	141
3	2041.7003	3,0	1	200
4	2041.7004	3,0	1	200
5	2041.7005	2,6	1	601
6	2041.7006	2,6	1	602
7	2041.7007	0,3	2	
8	2041.7008	1,7	1	260/080
9	2041.7009	1,7	1	260/080
10	2041.7010	0,9	2	
11	2041.7011	1,8	1	140/080
12	2041.7012	1,8	1	140/080
13	2041.7013	1,7	1	140
14	2041.7014	1,7	1	140
15	2041.7015	2,1	1	080
16	2041.7016	2,1	1	080
17	2041.7017	3,3	1	200
18	2041.7018	3,3	1	200
19	2041.7019	2,7	1	260
20	2041.7020	2,7	1	260
21	2041.7021	2,4	1	260
22	2041.7022	2,4	1	260

M 8-25	4
M 12-40	2
M 12-45	2
M 10x1,25-25	2
M 10x1,25-30	4
M 12x1,25-50	2
M 14x1,50-50	2
M 14x1,50-90	2

○ Avec ou sans mécanique
With or without mechanical elements
Con o senza parti meccaniche
Mit oder ohne Aggregate
Con ó sin mecanica desmontada

FIAT

2041.300

52 Kg 03.02.2004 411-D-22A

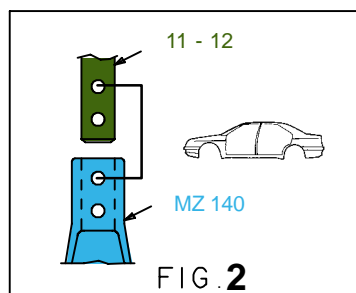
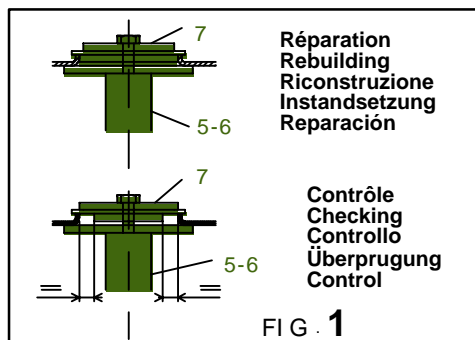
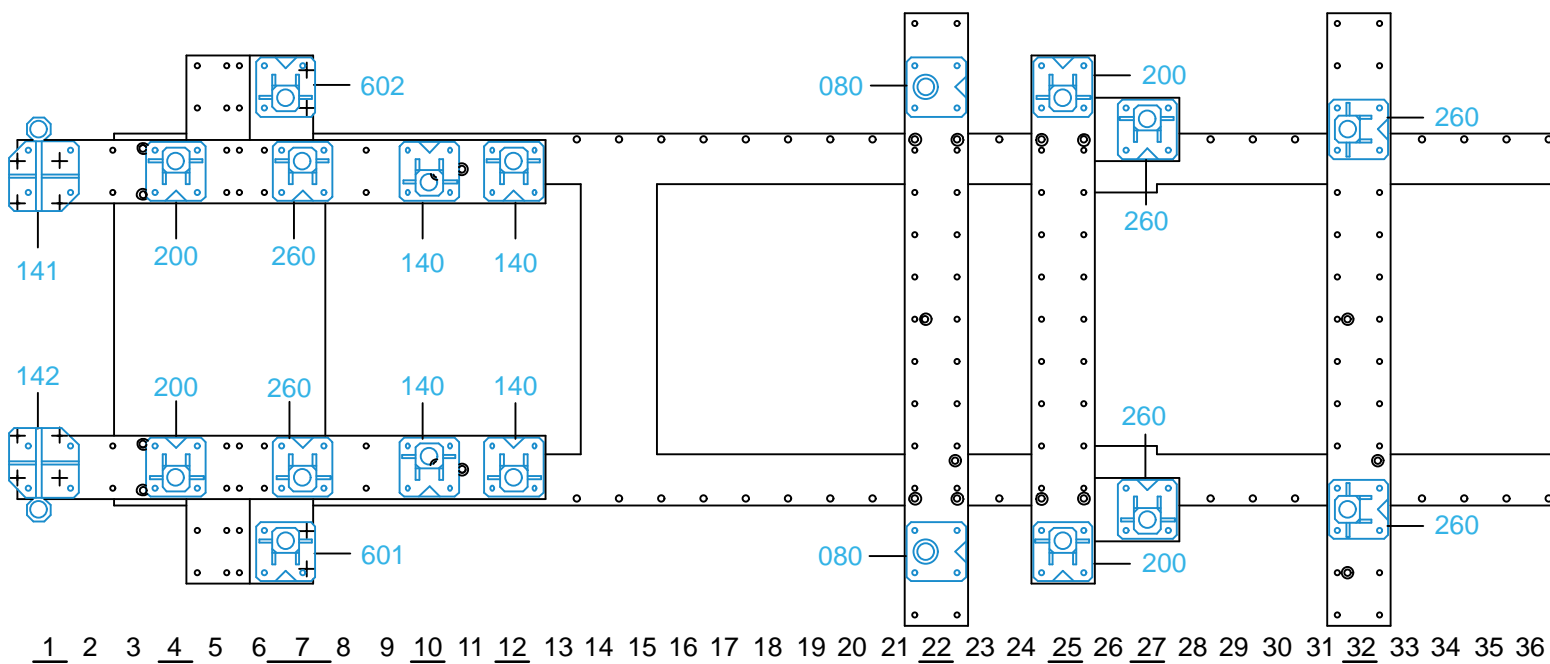

2041.300-RVA3-1 00

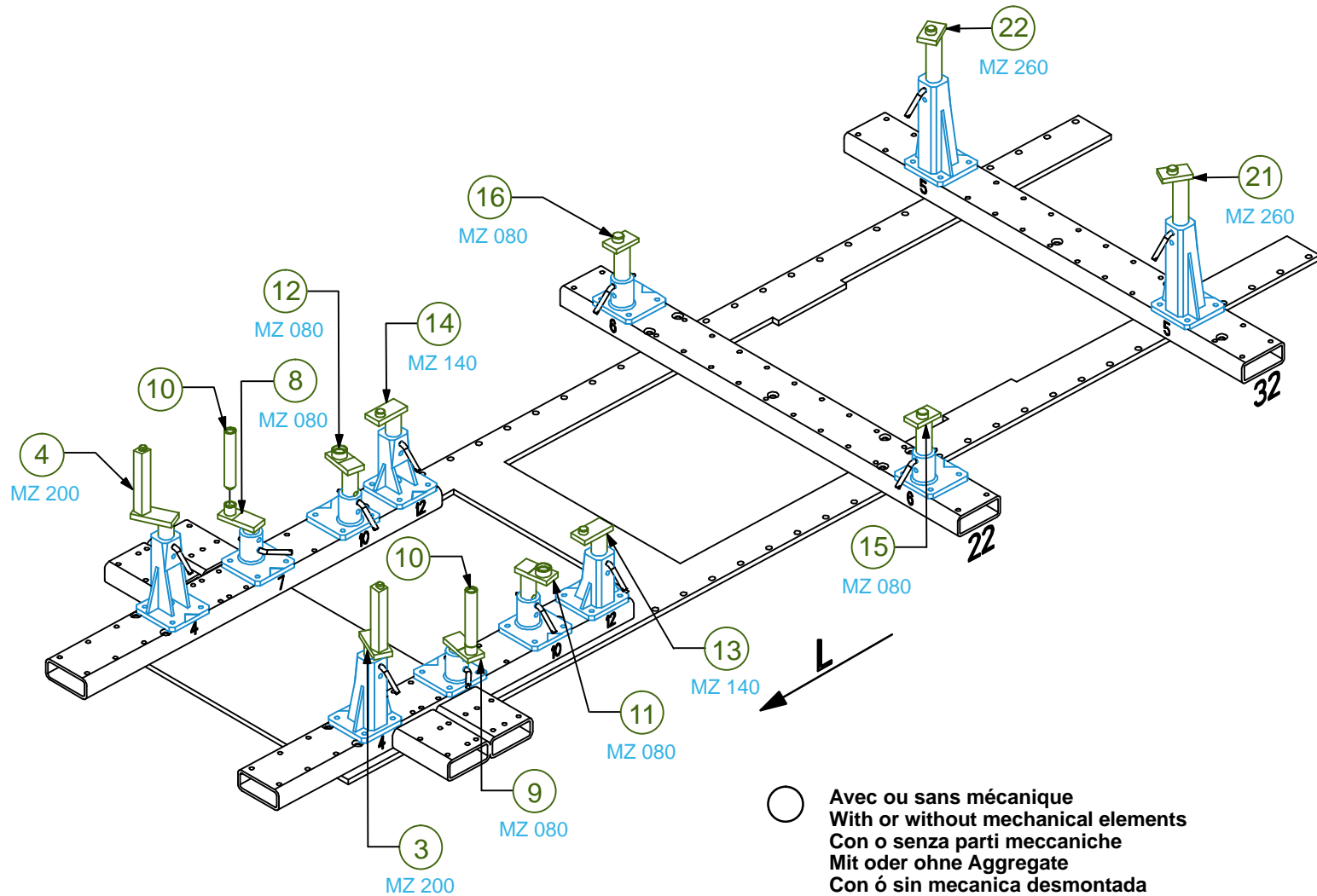

FIAT

2041.300		
52 Kg	03.02.2004	411-D-22B

