

REP.	REFERENCE	PDS	NB	MZ
1	2038.7001	3,9	1	141
2	2038.7002	3,9	1	142
3	2038.7003	0,3	2	
4	2038.7004	3,2	1	
5	2038.7005	3,2	1	
6	2038.7006	4,5	1	200
7	2038.7007	4,5	1	200
8	2038.7008	2,6	1	080
9	2038.7009	2,6	1	080
10	2038.7010	7,8	1	260
11	2038.7011	7,8	1	260
12	2038.7012	0,2	4	
13	2038.7013	0,2	4	
14	2038.7014	0,9	1	
15	2038.7015	0,9	1	
16	2038.7016	4,4	1	
17	2038.7017	1,1	2	
18	2038.7018	1,7	1	140/080
19	2038.7019	1,7	1	140/080
20	2038.7020	1,8	1	140
21	2038.7021	1,8	1	140
22	2038.7022	5,7	1	
23	2038.7023	5,7	1	
24	2038.7024	0,9	1	
25	2038.7025	0,9	1	
26	2038.7026	3,5	1	
27	2038.7027	3,5	1	
28	2038.7028	1,0	1	
29	2038.7029	1,0	1	
30	2038.7030	1,7	1	200/140
31	2038.7031	1,7	1	200/140
32	2038.7032	3,0	1	602
33	2038.7033	3,0	1	601
34	2038.7034	0,5	2	
35	2038.7035	1,8	1	260/200
36	2038.7036	1,8	1	260/200
37	2038.7037	2,8	1	260
38	2038.7038	2,9	1	140
39	2038.7039	0,05	6	
	V32	0,1	2	
	B76	0,1	8	

M 6-35	4
M 8-16	4
M 8-35	4
M 10-30	4
M 10-40	4
M 10-70	4
M 12-25	8
M 12x1,50-60	2
M 12x1,50-70	6
M 12x1,50-130	4
M 12x1,50-140	2
M 10	4
LU 12	4
MU 12	2

# 2038.300

105 Kg    12.01.2004    403-D-18A

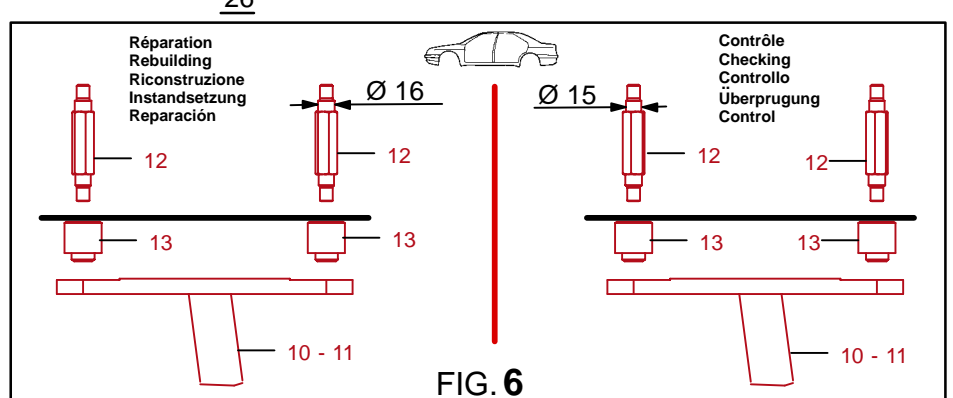
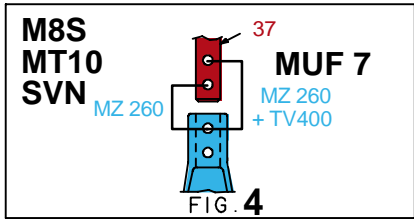
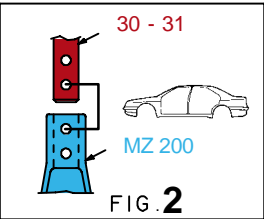
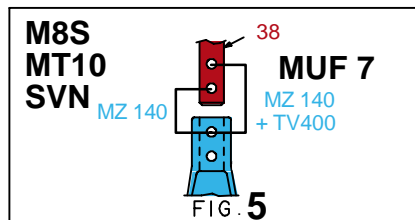
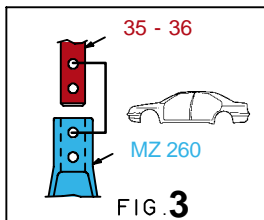
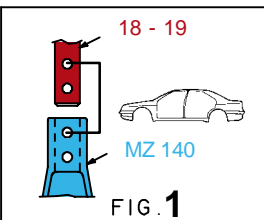
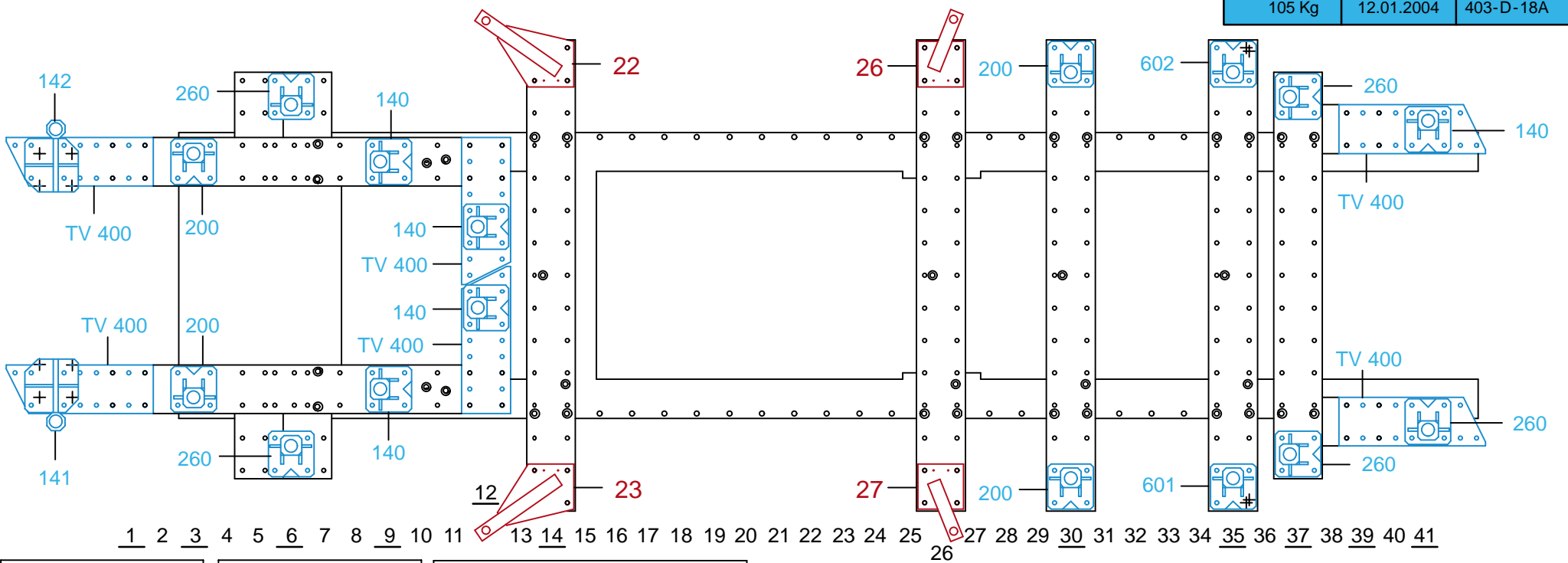

2038.300-RVA3-1 00



M8S  
MT10  
SVN

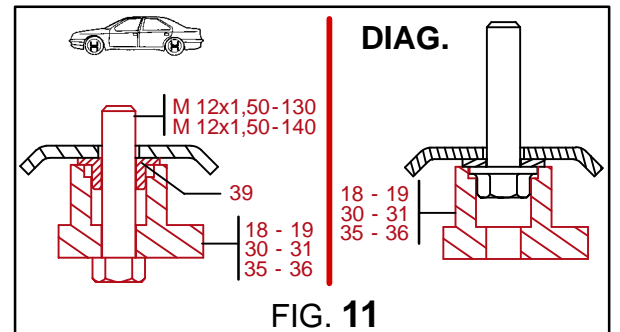
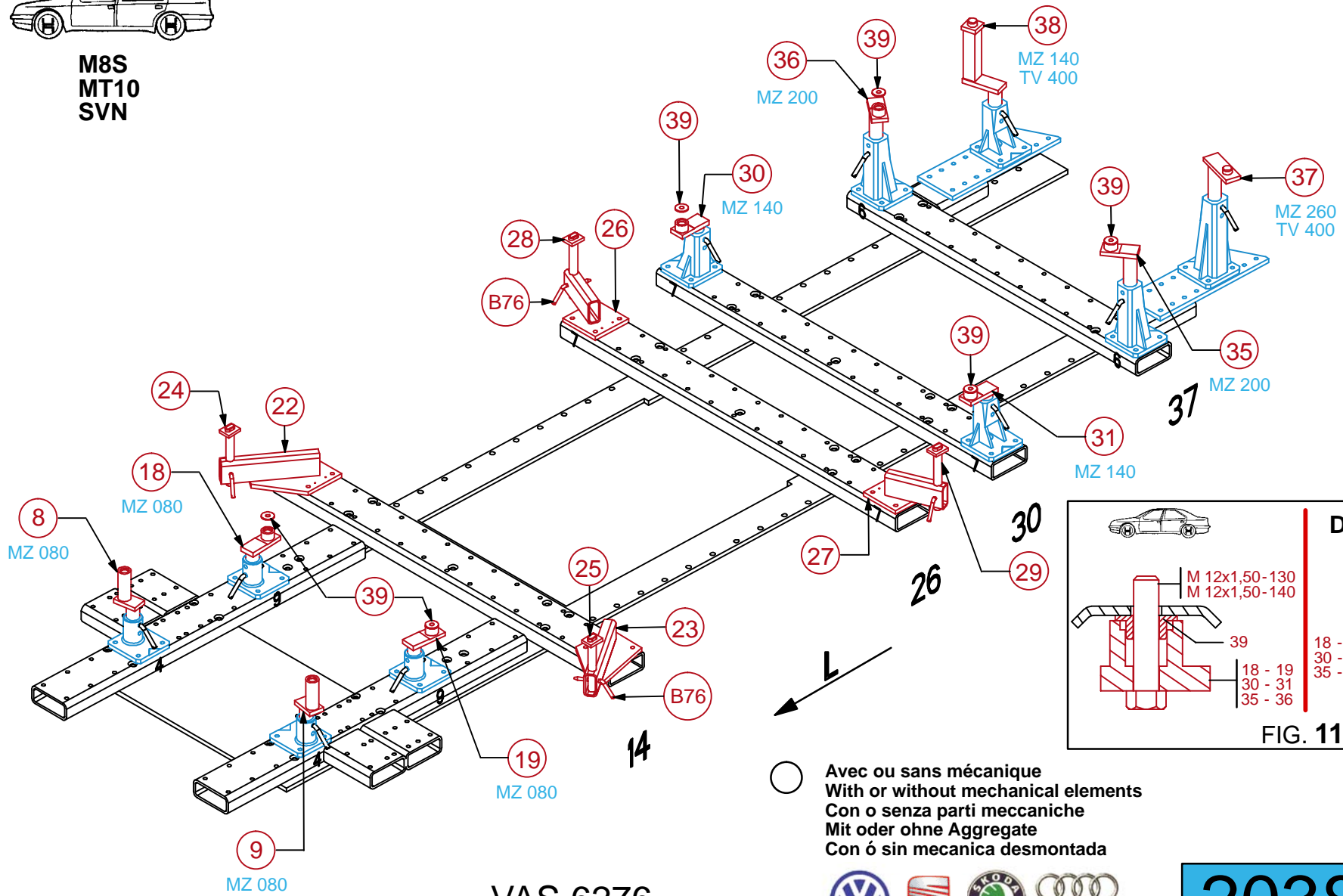

○ Avec ou sans mécanique  
With or without mechanical elements  
Con o senza parti meccaniche  
Mit oder ohne Aggregate  
Con ó sin mecanica desmontada

**VAS 6276**



**2038.300**  
105 Kg | 12.01.2004 | 403-D-18B

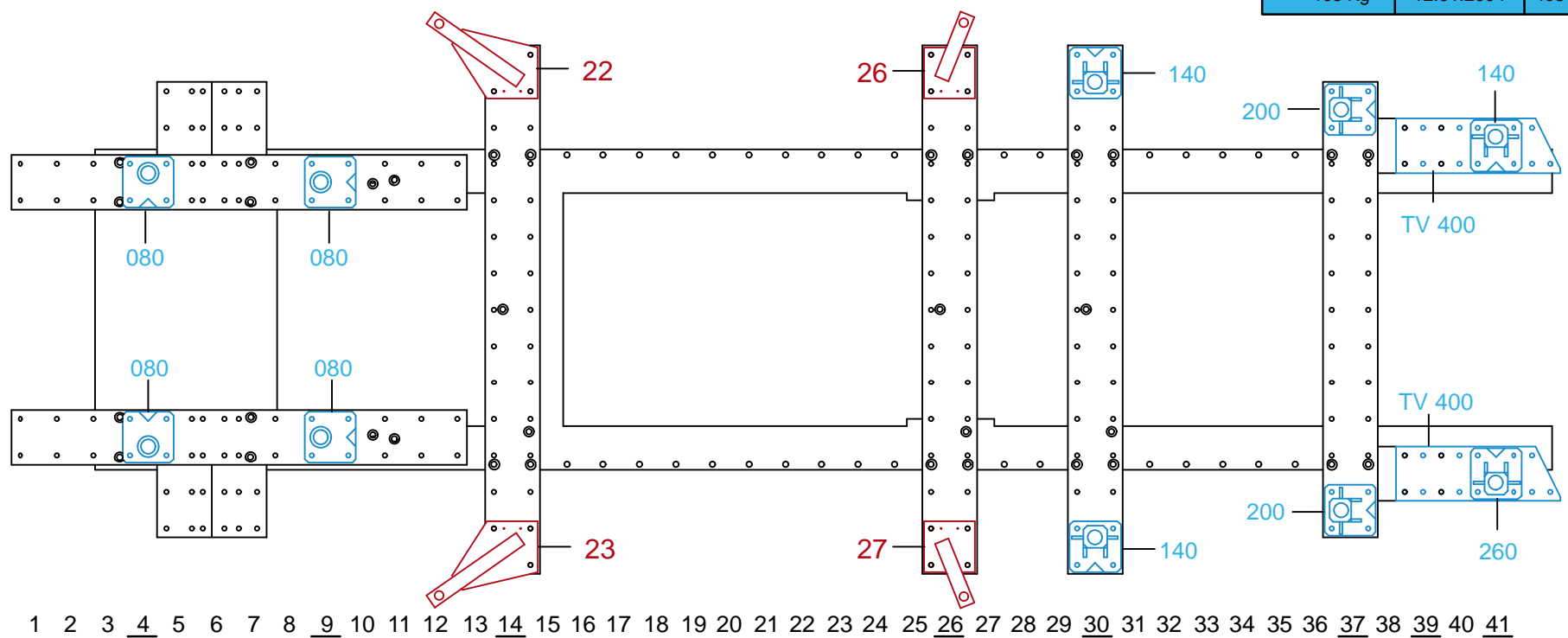

1 2 3 4 5 6 7 8 9 10 11 12 13 14 15 16 17 18 19 20 21 22 23 24 25 26 27 28 29 30 31 32 33 34 35 36 37 38 39 40 41

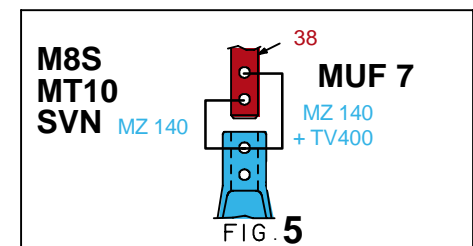
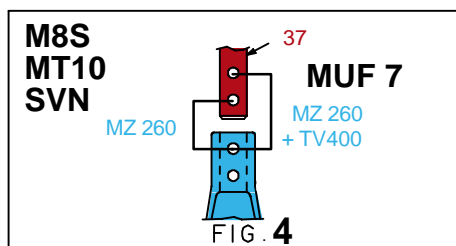
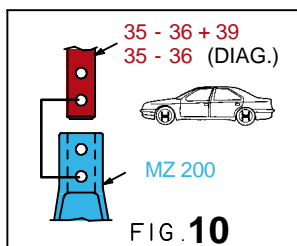
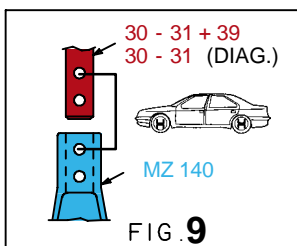
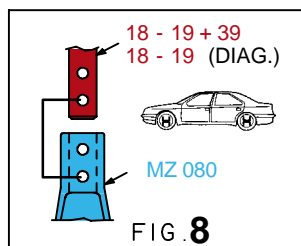



MUF 7

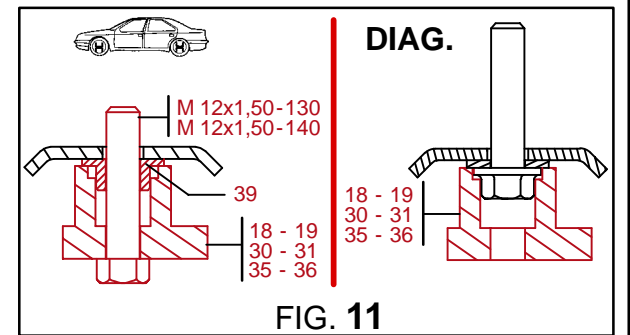
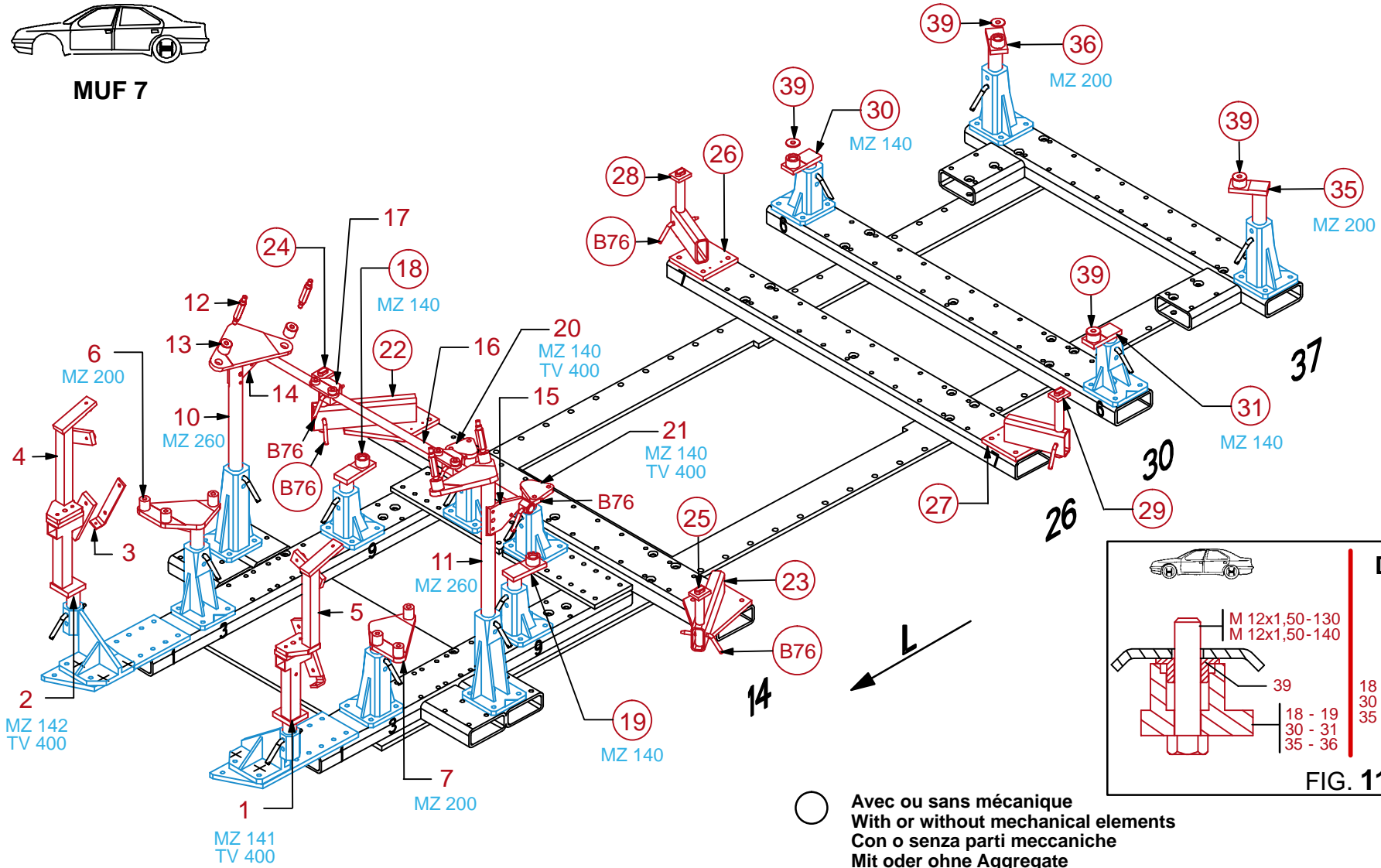

○ Avec ou sans mécanique  
With or without mechanical elements  
Con o senza parti meccaniche  
Mit oder ohne Aggregate  
Con ó sin mecánica desmontada

VAS 6276



**2038.300**

105 Kg	12.01.2004	403-D-18C
--------	------------	-----------

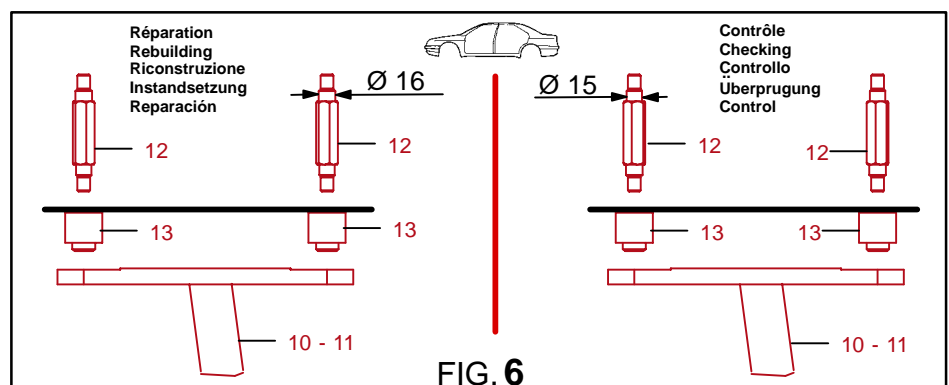
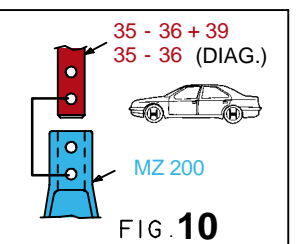
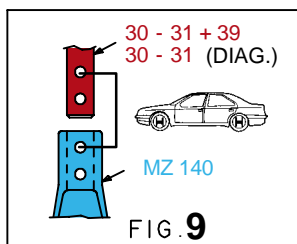
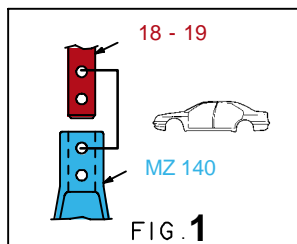
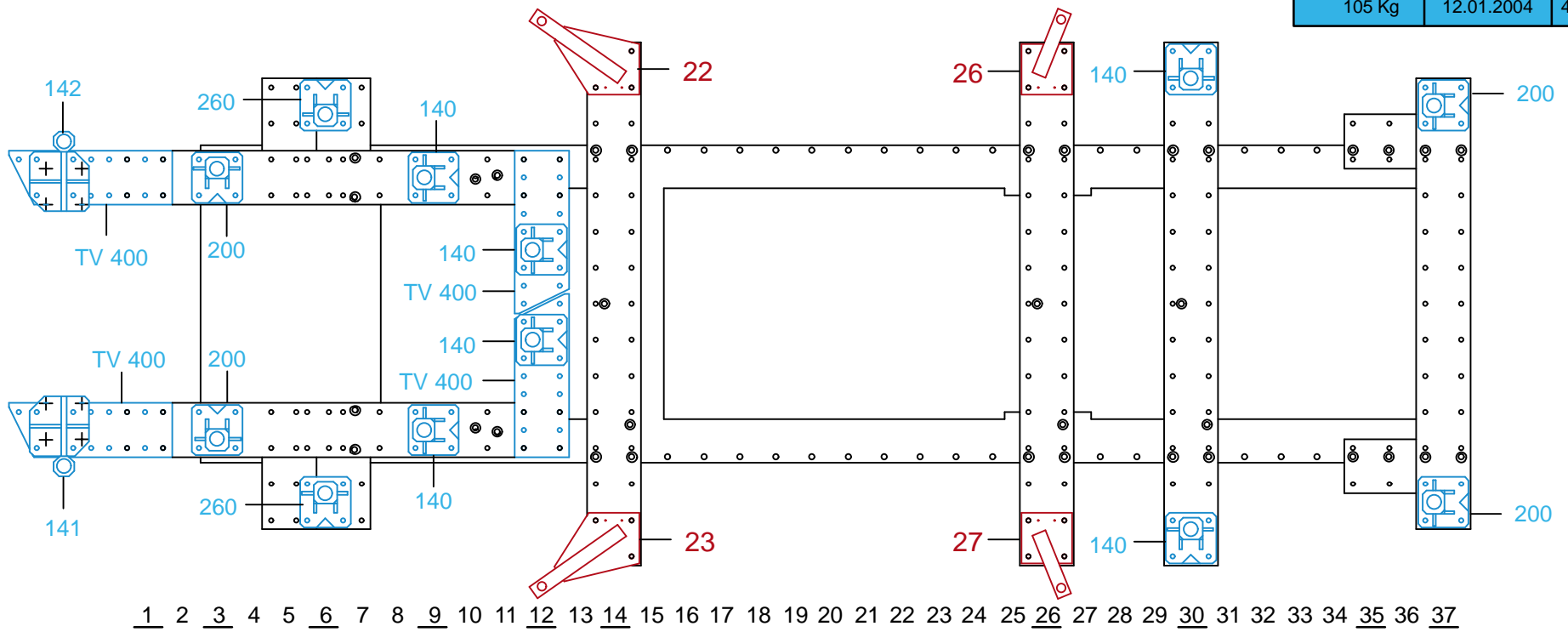

2038.300-RVA3-2 00



MUF 7

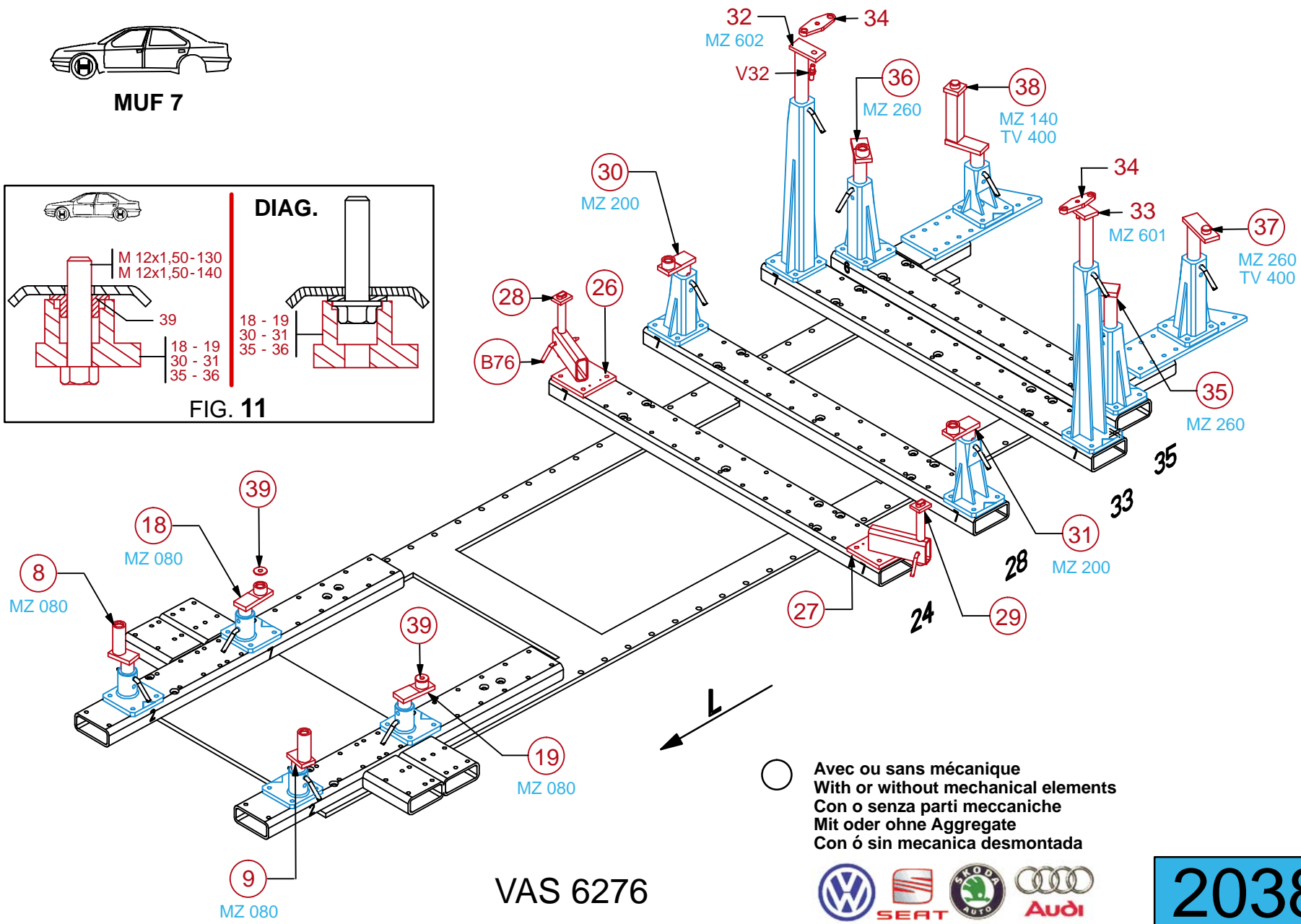
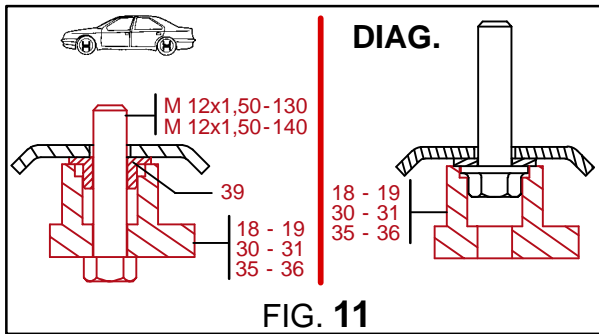

**2038.300**

105 Kg | 12.01.2004 | 403-D-18D

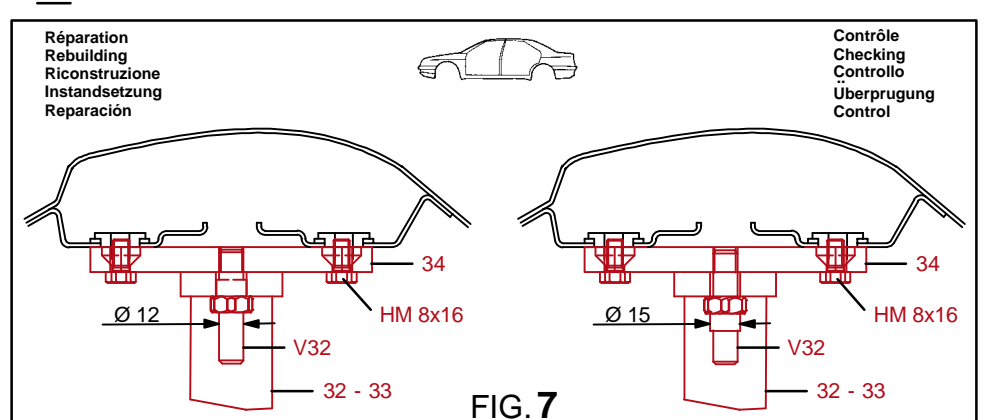
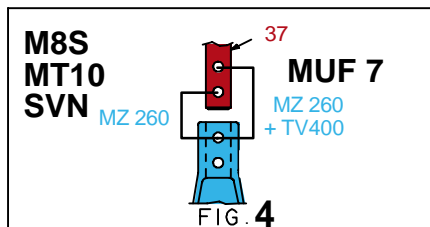
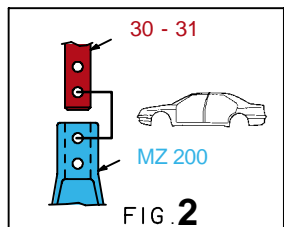
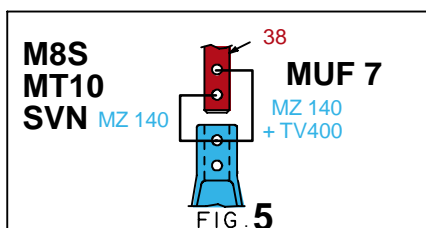
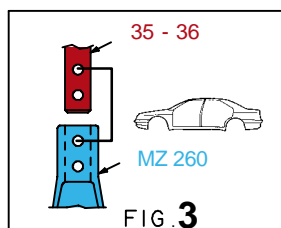
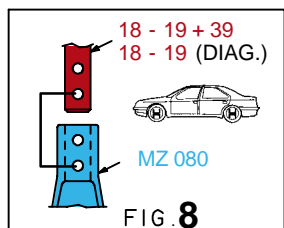
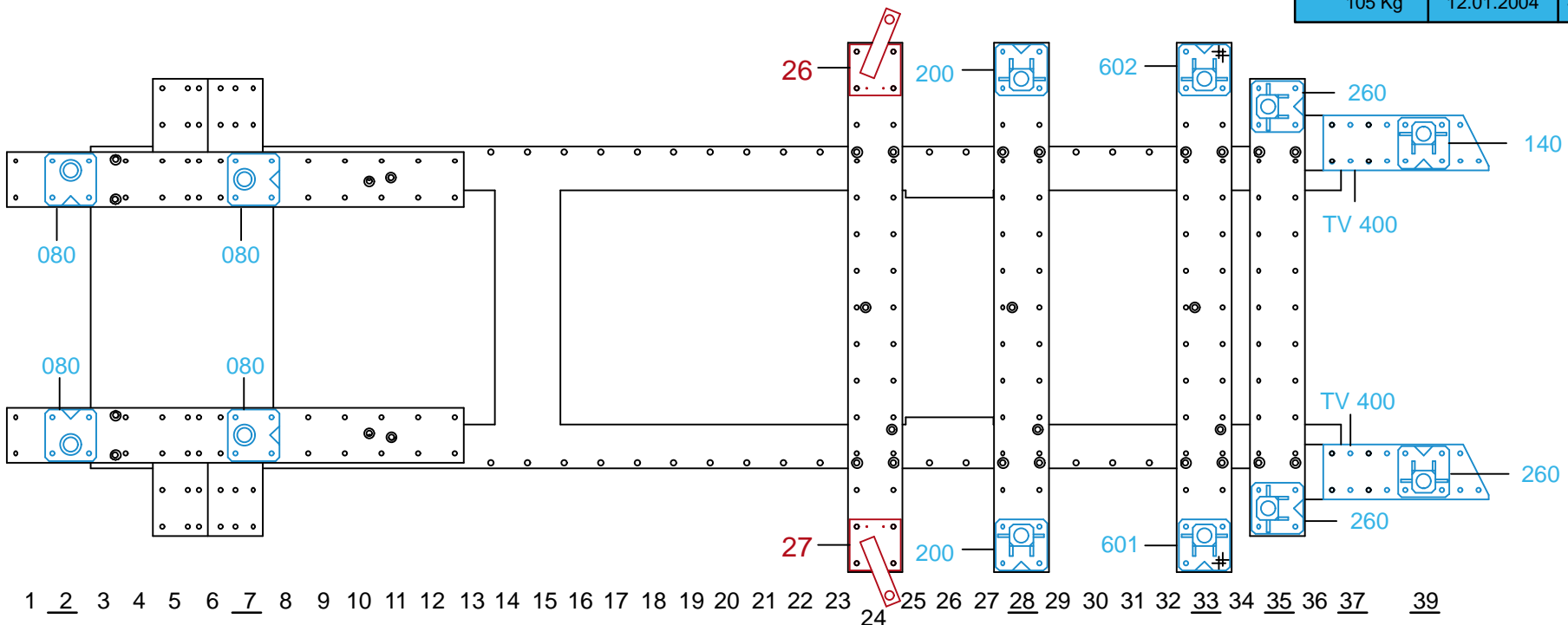

2038.300-RVA3-2 | 00