

REP.	MOD.
31 + 70	→ 04/2002
31	05/2002 →

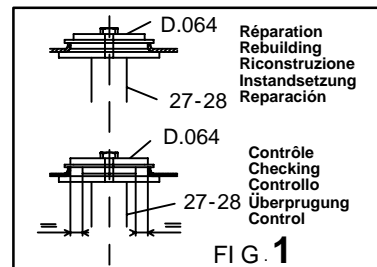

REP.	REFERENCE	PDS	NB	MZ
31	2030.7031	2,3	1	260
32	2030.7032	2,1	1	602
33	2030.7033	2,1	1	601
69	2030.7069	1,0	2	
70	2030.7070	0,05	1	
	V32	0,1	2	

M 8-20	6
M 10x1,25-25	1
M 10	1

complément au
complementary set to
complemento al
zusatz zu

2030.300
+
2030.309

2030.307

20 Kg	18.05.2005	421-D-32G
-------	------------	-----------

○ Avec ou sans mécanique
With or without mechanical elements
Con o senza parti meccaniche
Mit oder ohne Aggregate
Con ó sin mecanica desmontada

MITSUBISHI

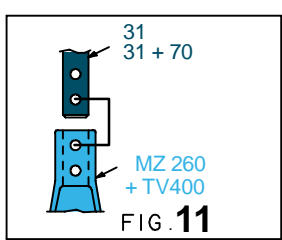
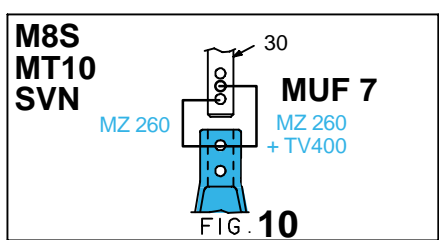
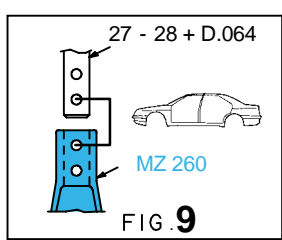
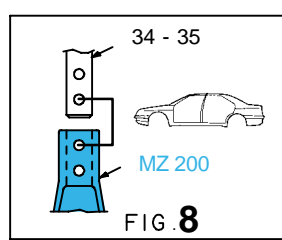
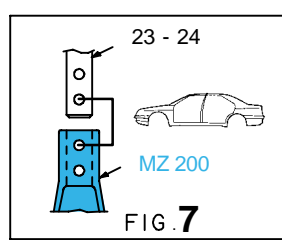
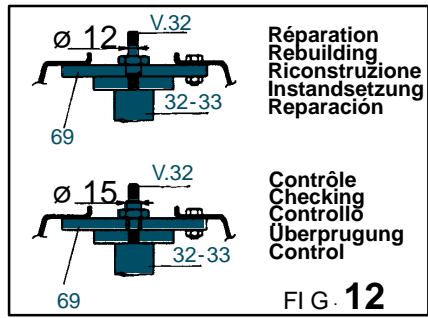
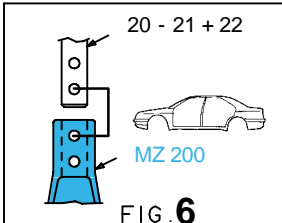
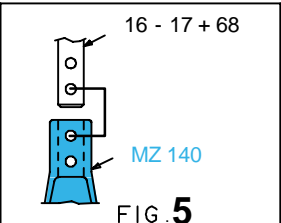
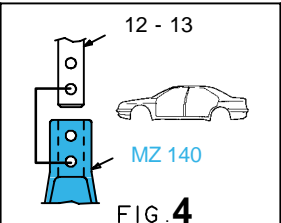
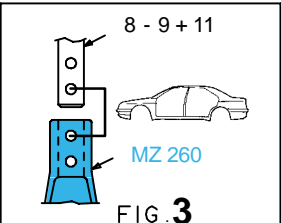
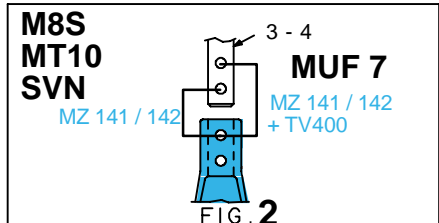
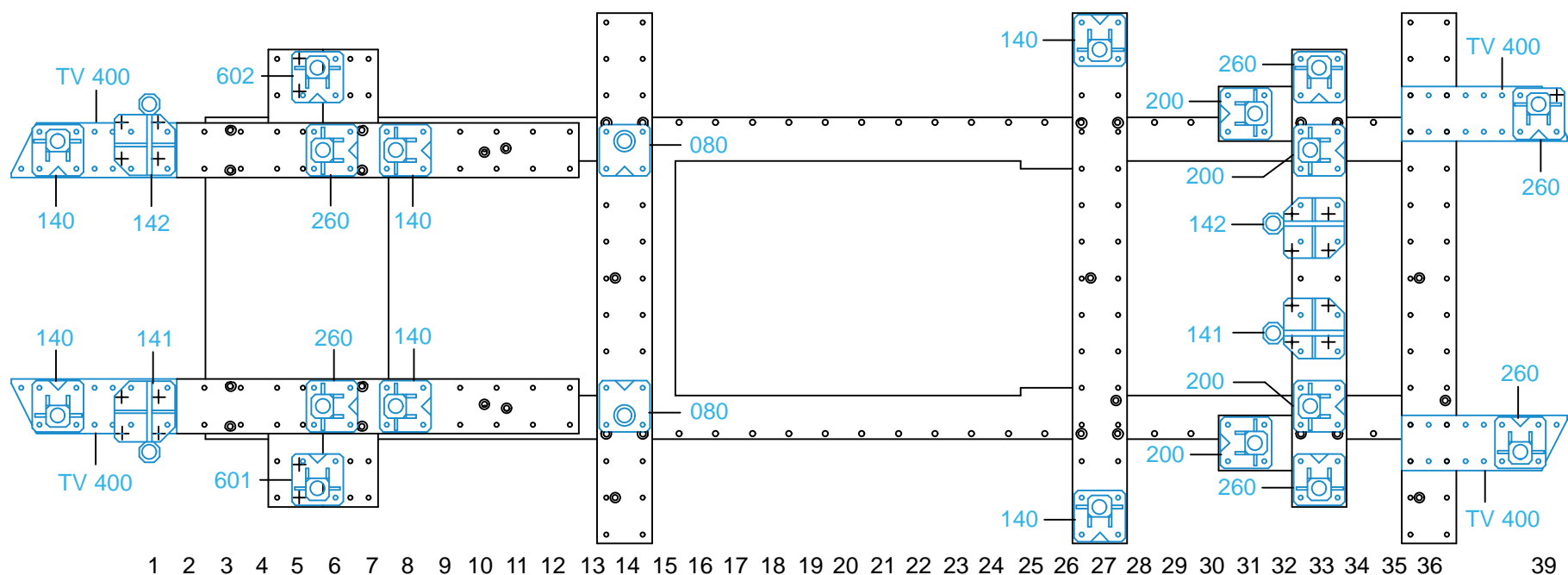

2030.307-RVA3-1 00

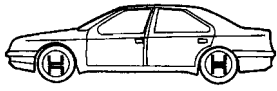

REP.	MOD.
31 + 70	→ 04/2002
31	05/2002 →

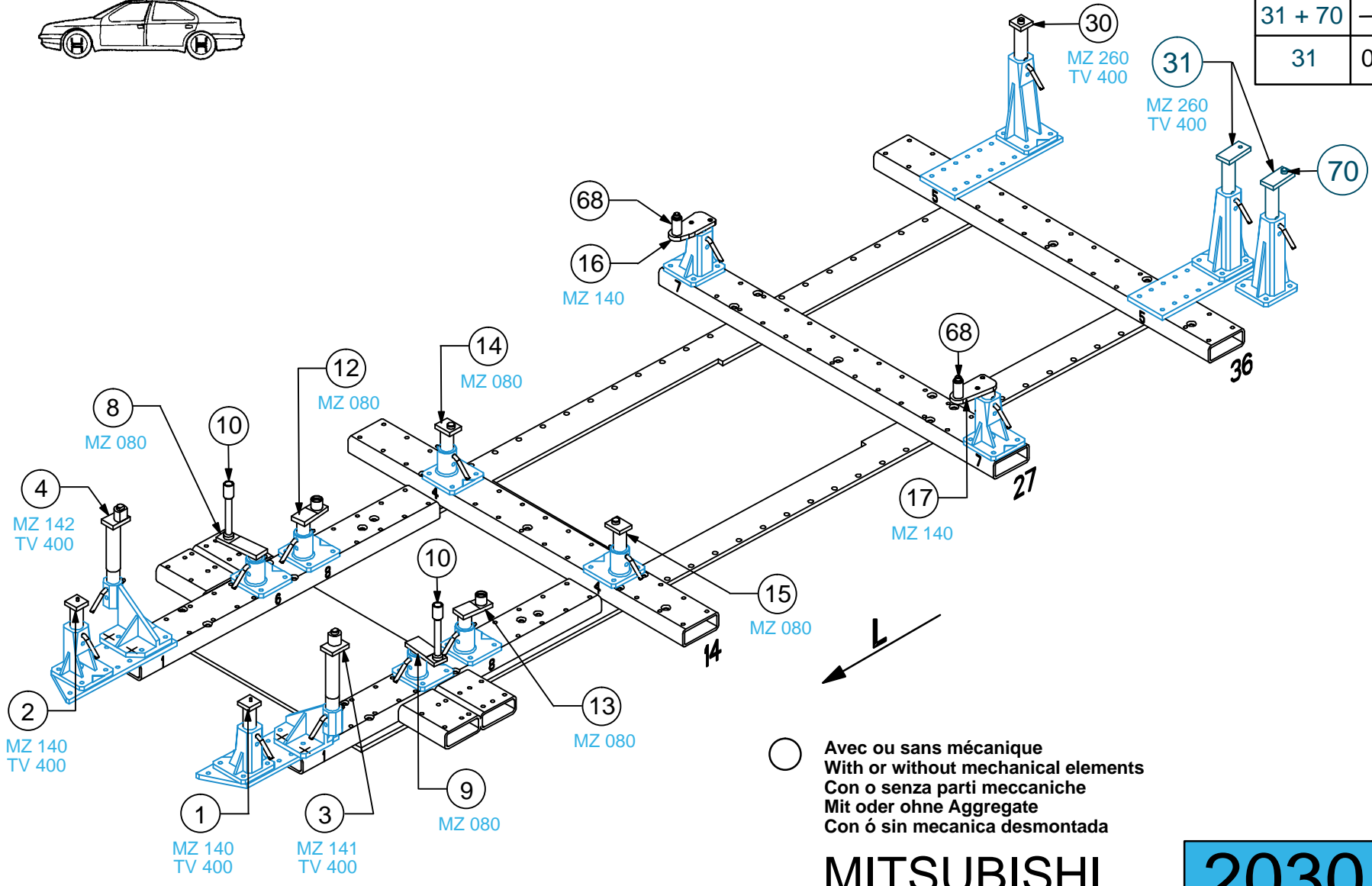

○ Avec ou sans mécanique
 With or without mechanical elements
 Con o senza parti meccaniche
 Mit oder ohne Aggregate
 Con ó sin mecanica desmontada

MITSUBISHI

2030.307

20 Kg	18.05.2005	421-D-32H
-------	------------	-----------

