

REP.	REFERENCE	PDS	NB	MZ
1	2014.7001	1,5	1	140
2	2014.7002	1,6	1	140
3	2014.7003	2,3	1	260
4	2014.7004	2,3	1	260
5	2014.7005	2,5	1	601
6	2014.7006	2,5	1	602
7	2014.7007	0,2	2	
8	2014.7008	1,7	1	140/080
9	2014.7009	1,7	1	140/080
10	2014.7010	0,8	2	
11	2014.7011	0,6	2	
12	2014.7012	1,8	1	080
13	2014.7013	1,8	1	080
14	2014.7014	1,8	1	080
15	2014.7015	1,8	1	080
16	2014.7016	1,5	1	141
17	2014.7017	1,5	1	142
18	2014.7018	2,5	1	200
19	2014.7019	2,5	1	200
20	2014.7020	2,0	1	602
21	2014.7021	2,0	1	601
22	2014.7022	2,2	1	260
23	2014.7023	2,2	1	260
24	2014.7024	2,7	2	

M 12-25	8
M 12-50	2
M 10x1,25-25	4
M 10x1,25-35	4
M 14x1,50-20	2
M 14x1,50-60	2
M 14x1,50-90	2
CHc TB 12-25	8

MU 14	2
-------	---

## DAEWOO / CHEVROLET / PONTIAC

# 2014.300

50 Kg    24.06.2003    449-D-8A

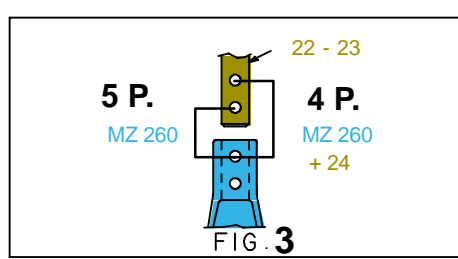
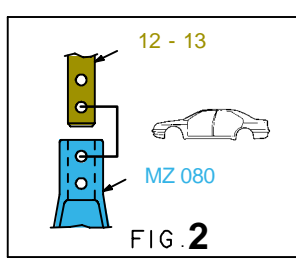
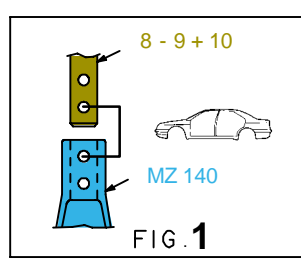
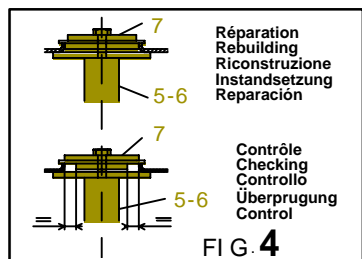
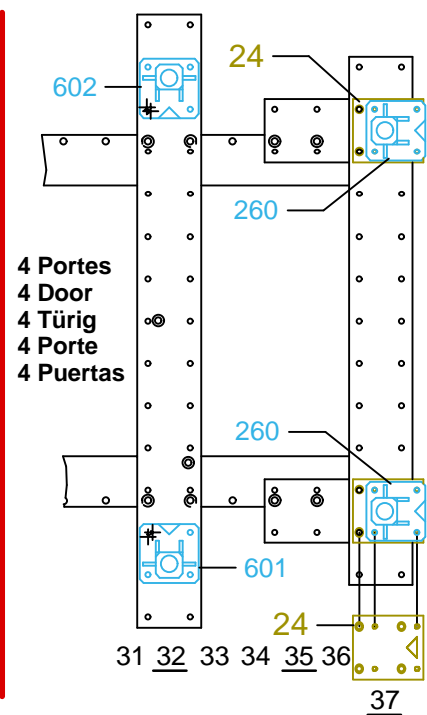
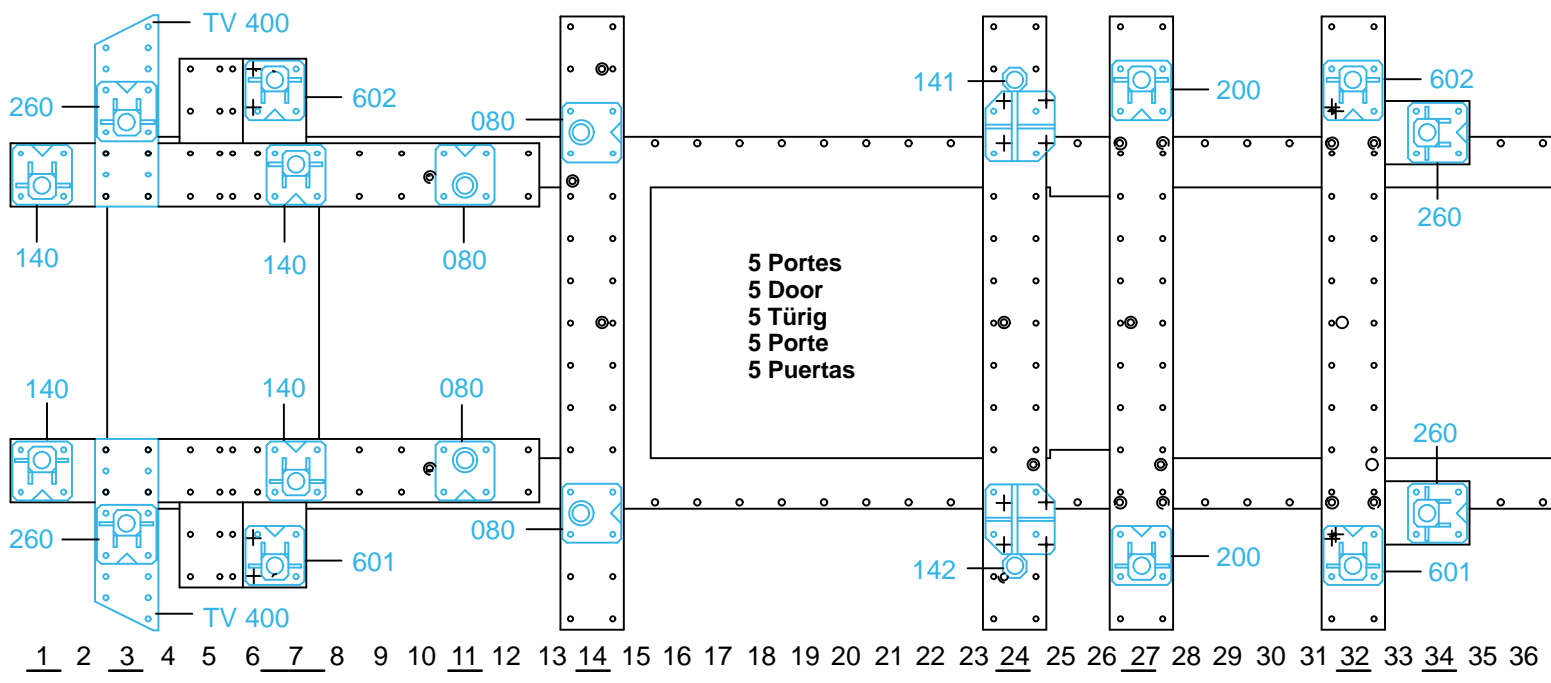

2014.300-RVA3-1 00



5 Portes  
5 Door  
5 Türlig  
5 Porte  
5 Puertas

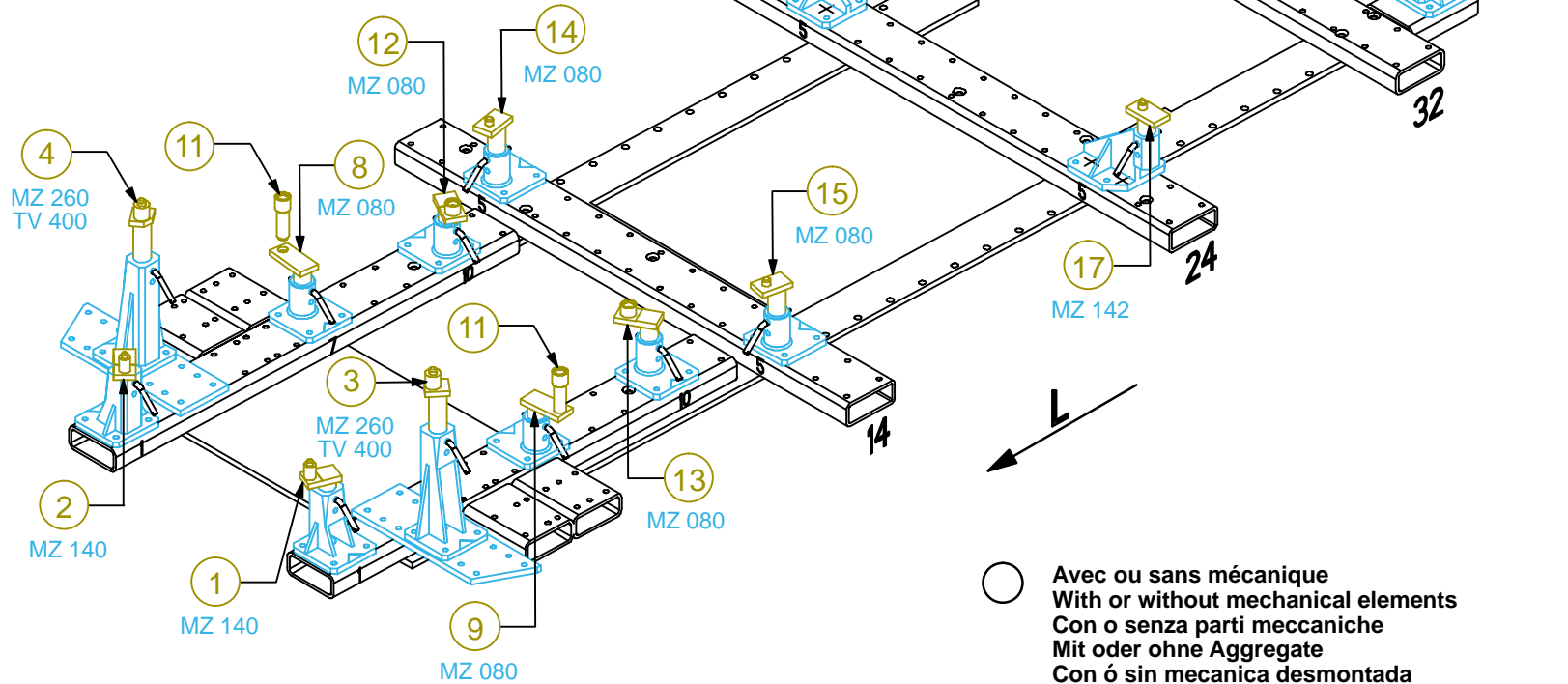
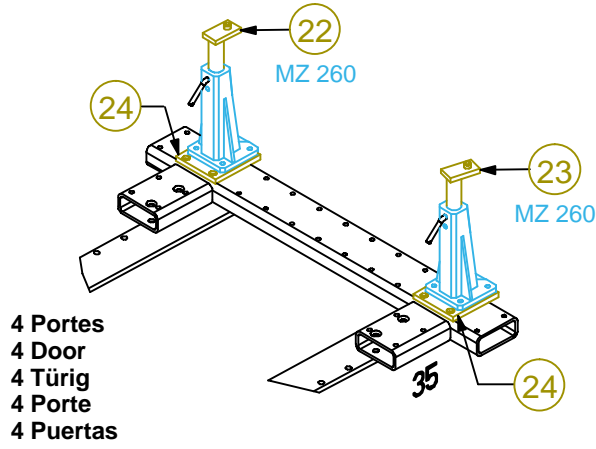

○ Avec ou sans mécanique  
With or without mechanical elements  
Con o senza parti meccaniche  
Mit oder ohne Aggregate  
Con ó sin mecánica desmontada

**DAEWOO / CHEVROLET / PONTIAC**

**2014.300**

50 Kg | 24.06.2003 | 449-D-8B

