

ANCRAGE DU VEHICULE  
ANCHORING OF THE VEHICLE  
VERANKERUNG DES FAHRZEUGS  
ANCORAGGIO DEL VEICOLO  
ANCLAJE DEL VEHICULO

**AN.27.B + AN27.03**  
Ou/Or/Oder/O  
**AN.34**

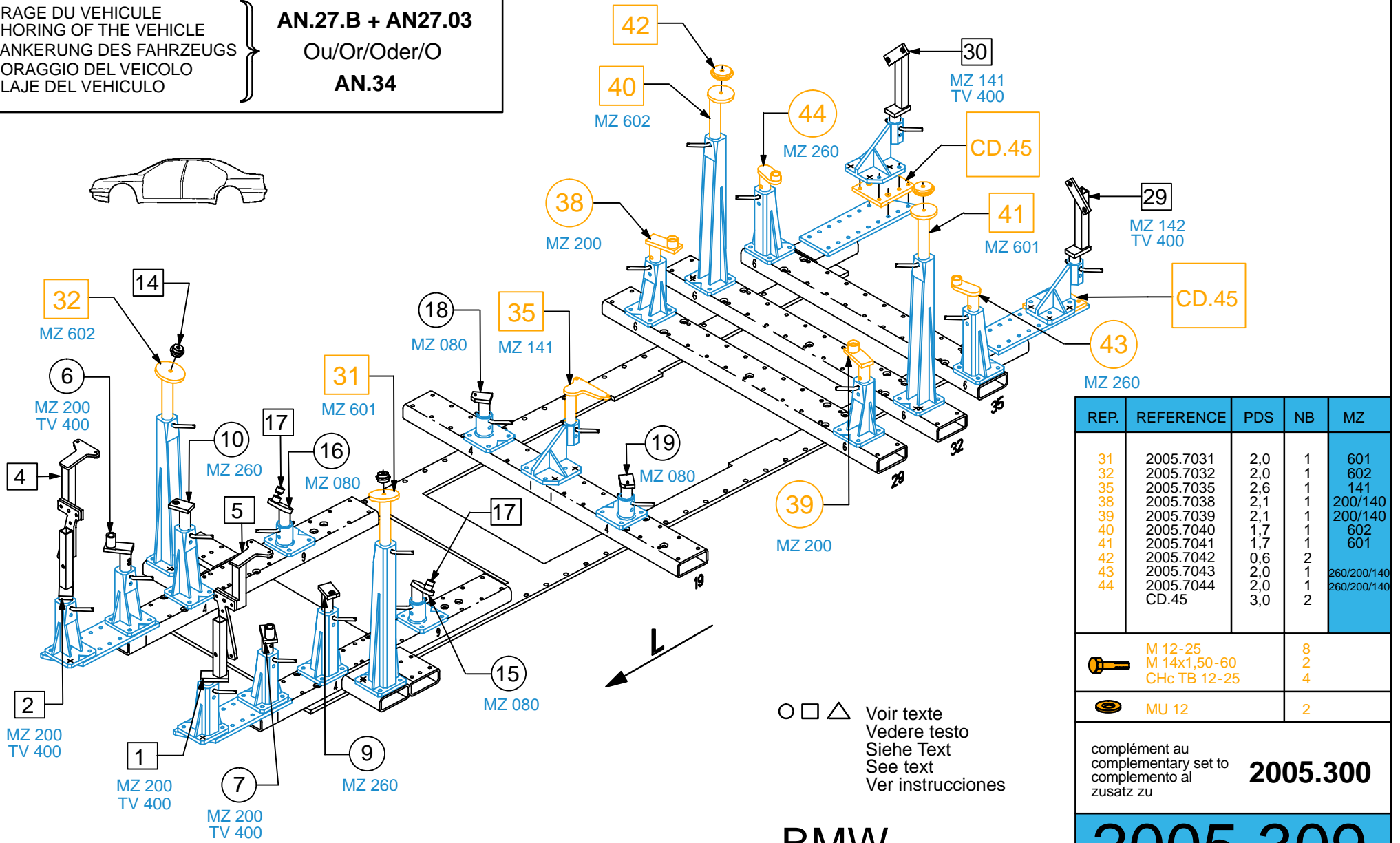

REP.	REFERENCE	PDS	NB	MZ
31	2005.7031	2,0	1	601
32	2005.7032	2,0	1	602
35	2005.7035	2,6	1	141
38	2005.7038	2,1	1	200/140
39	2005.7039	2,1	1	200/140
40	2005.7040	1,7	1	602
41	2005.7041	1,7	1	601
42	2005.7042	0,6	2	
43	2005.7043	2,0	1	260/200/140
44	2005.7044	2,0	1	260/200/140
	CD.45	3,0	2	

M 12-25 M 14x1,50-60 CHc TB 12-25	8 2 4
MU 12	2

complément au  
complementary set to  
complemento al  
zusatz zu **2005.300**

**2005.309**  
26 Kg 03.02.2004 406-D-21C

**BMW**

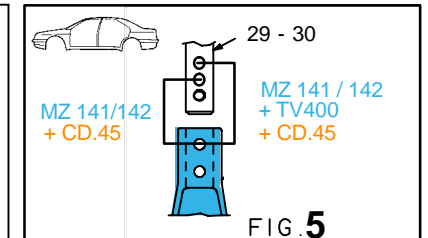
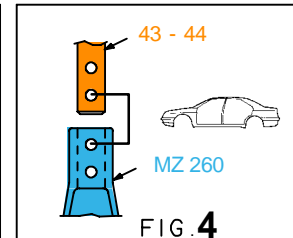
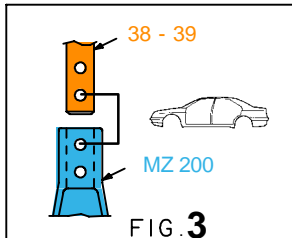
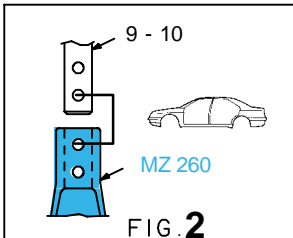
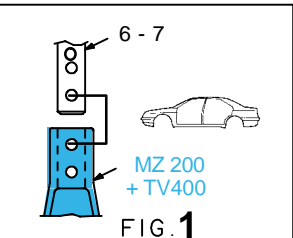
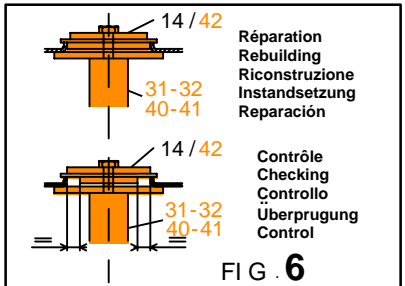
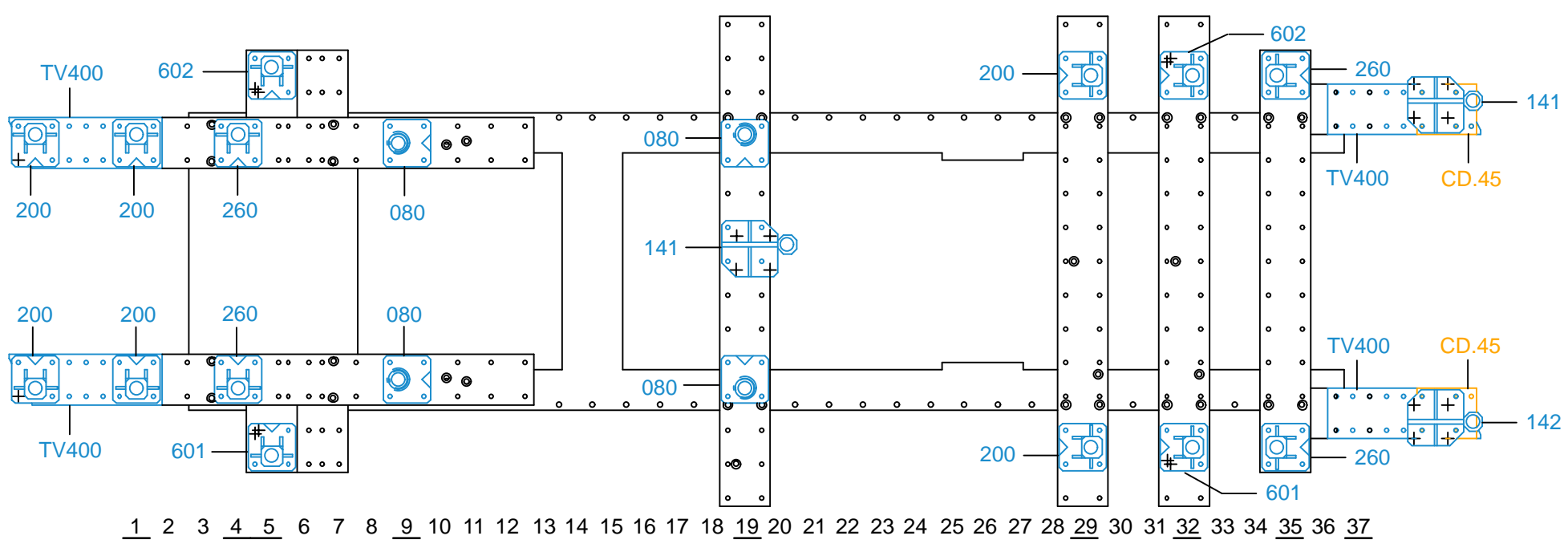

ANCRAGE DU VEHICULE  
ANCHORING OF THE VEHICLE  
VERANKERUNG DES FAHRZEUGS  
ANCORAGGIO DEL VEICOLO  
ANCLAJE DEL VEHICULO

**AN.27.B + AN27.03**  
Ou/Or/Oder/O  
**AN.34**

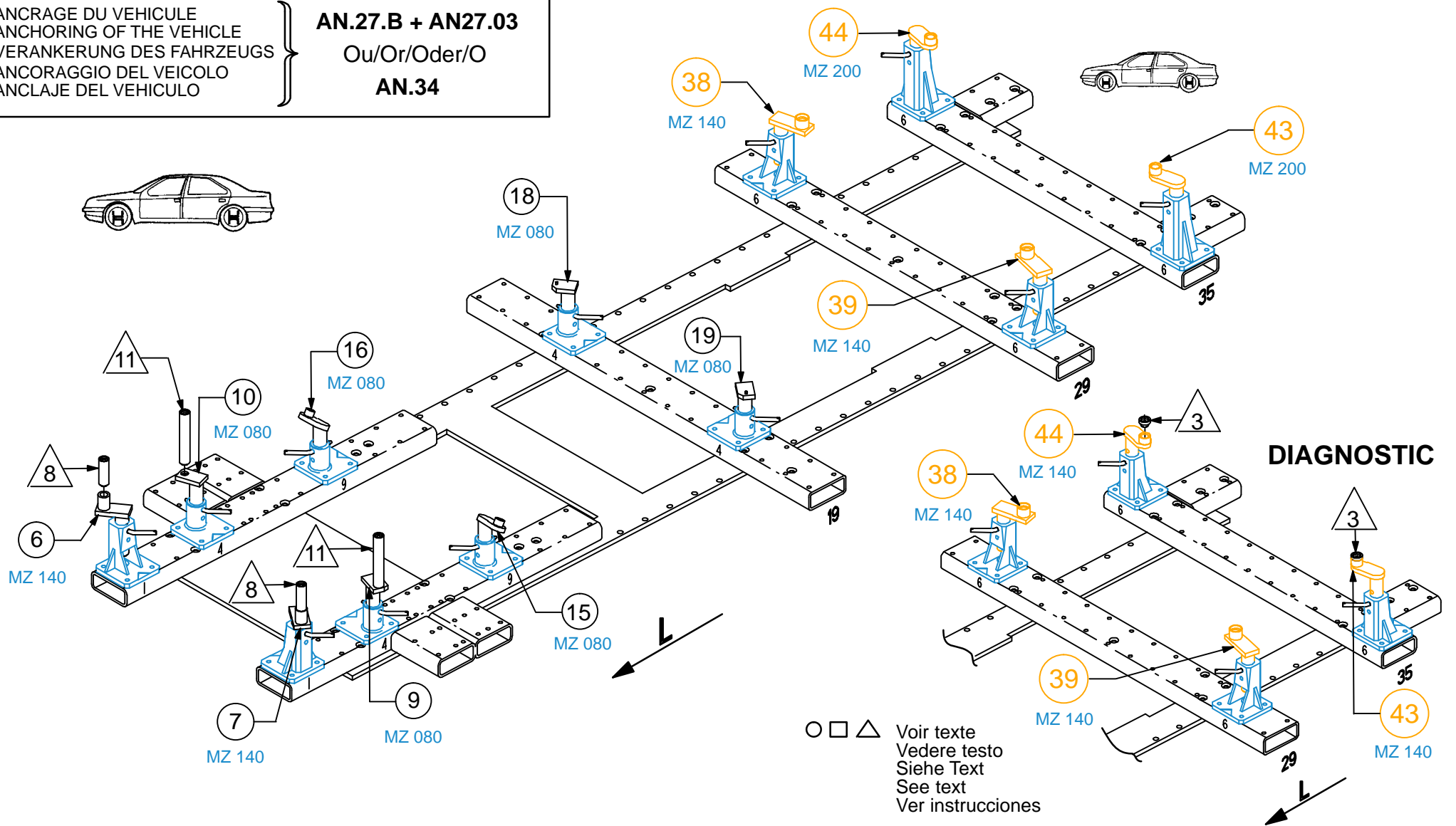

BMW

**2005.309**

26 Kg | 08.10.2003 | 406-D-21D

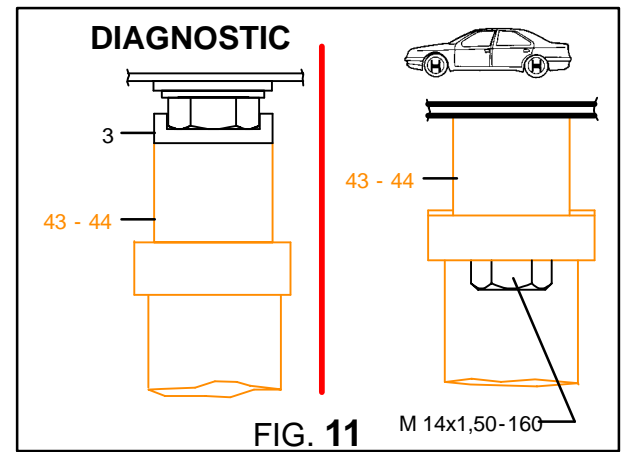
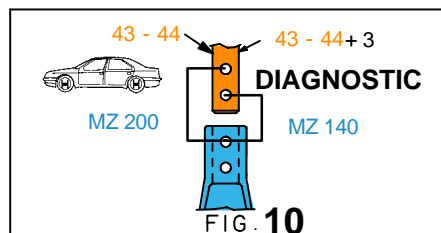
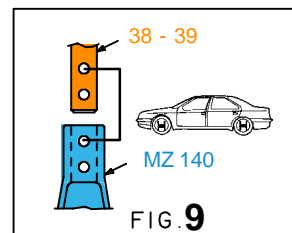
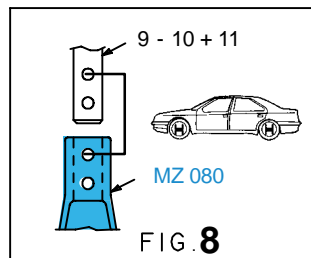
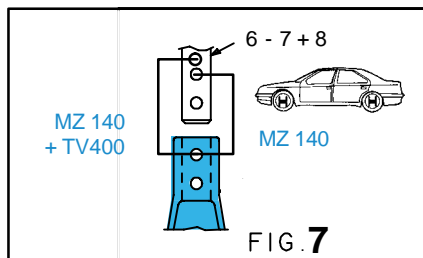
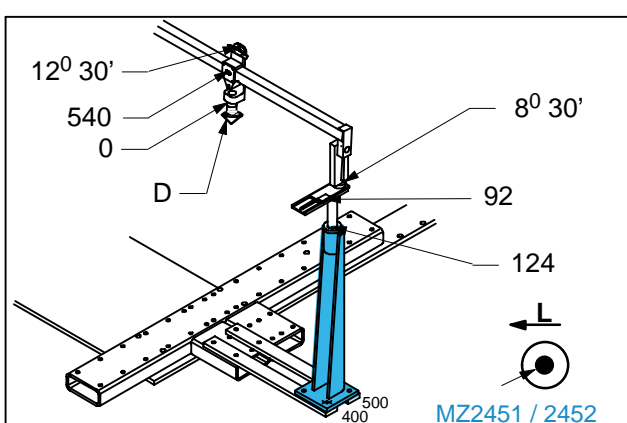
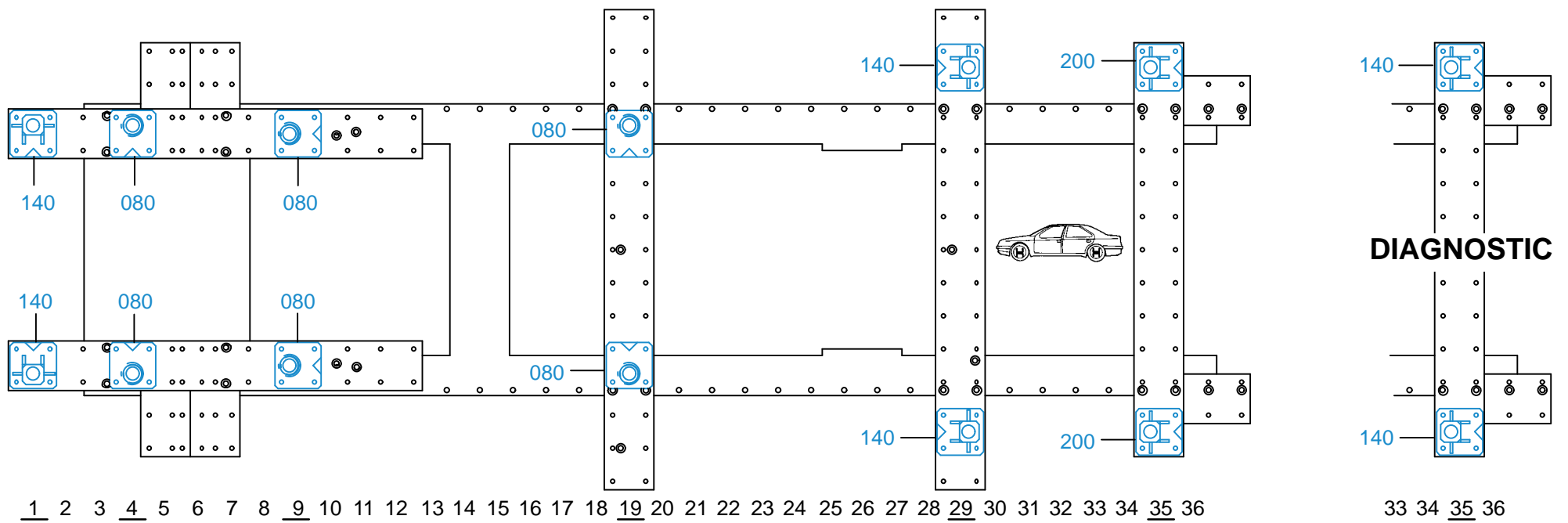

2005.309-RVA3-1 | 01