

ANCRAGE DU VEHICULE  
ANCHORING OF THE VEHICLE  
VERANKERUNG DES FAHRZEUGS  
ANCORAGGIO DEL VEICOLO  
ANCLAJE DEL VEHICULO

**AN.27.B + AN27.03**  
Ou/Or/Oder/O  
**AN.34**

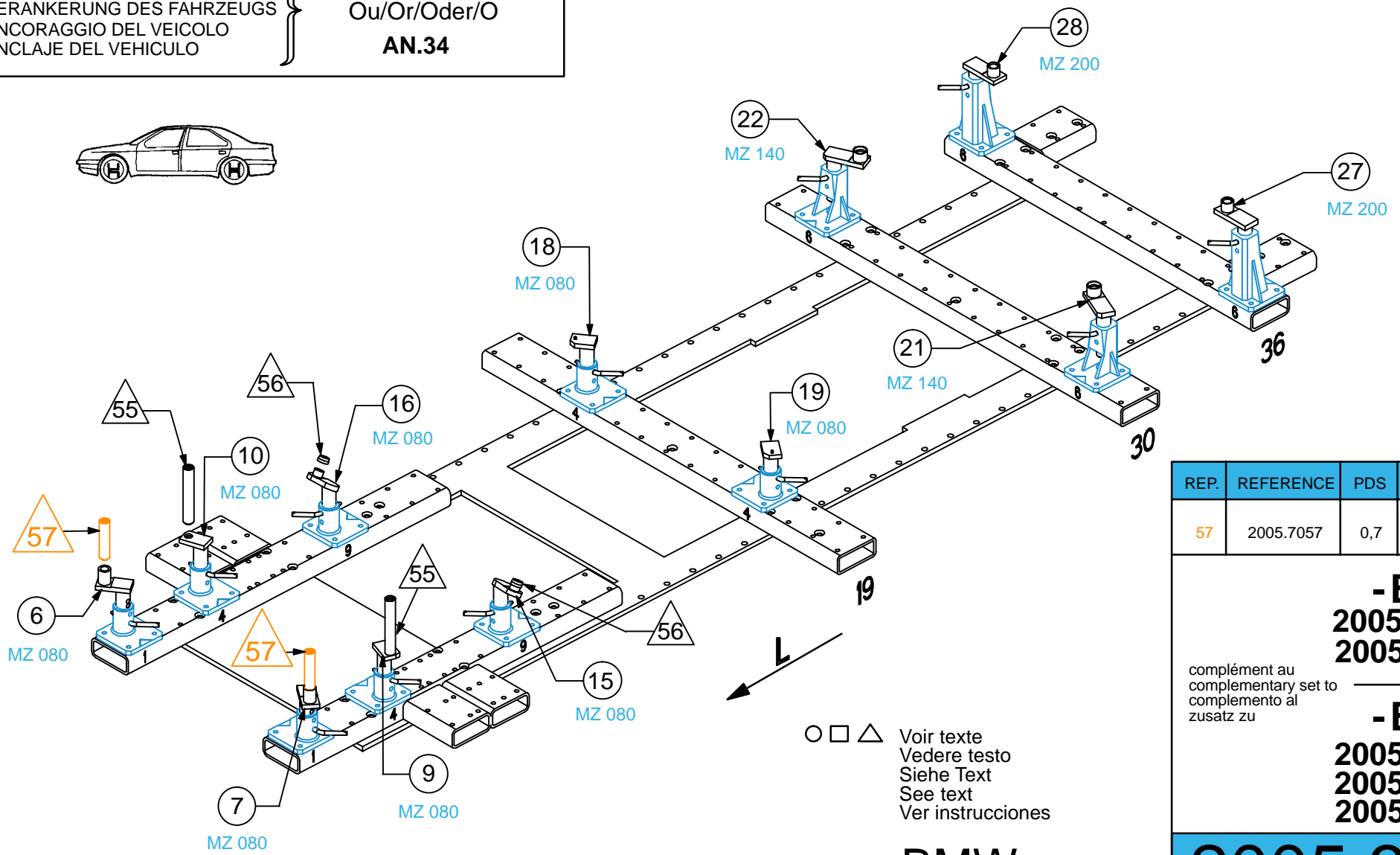

REP.	REFERENCE	PDS	NB	MZ
57	2005.7057	0,7	2	

**- E60 -**  
**2005.300 +**  
**2005.303**

complément au  
complementary set to  
complemento al  
zusatz zu

**- E61 -**  
**2005.300 +**  
**2005.305 +**  
**2005.303**

<b>2005.301</b>				
1,4 Kg	03.10.2006	406-D-21R		

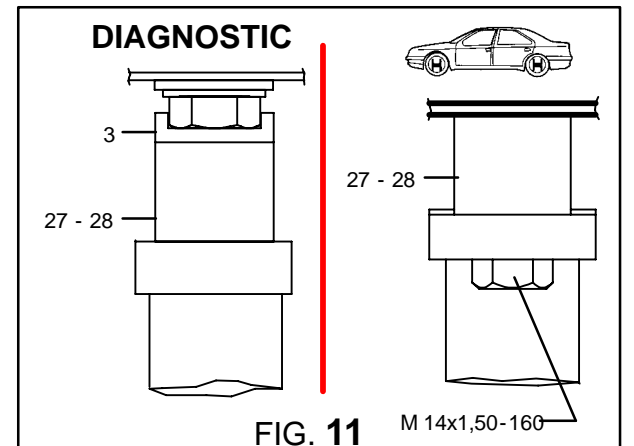
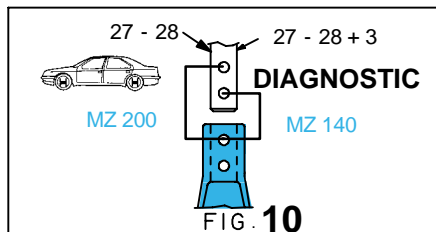
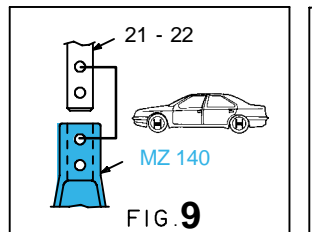
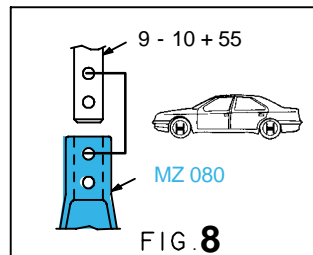
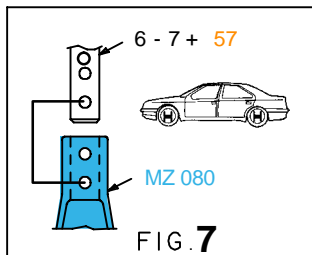
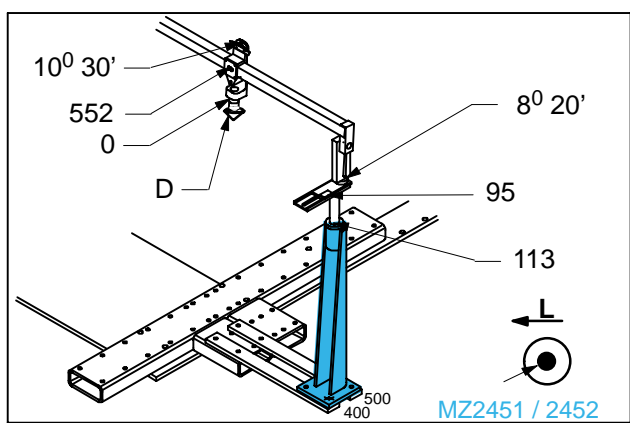
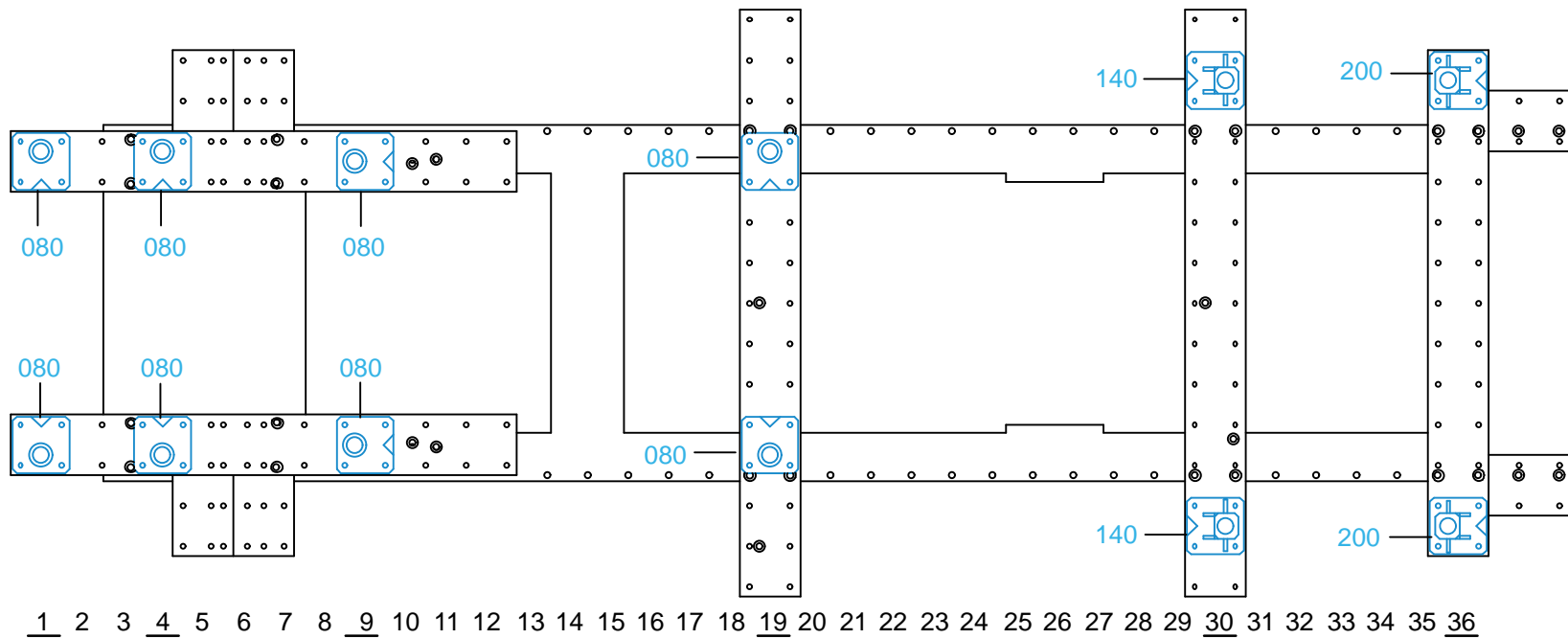

2005.301-RA3-1 | 00